

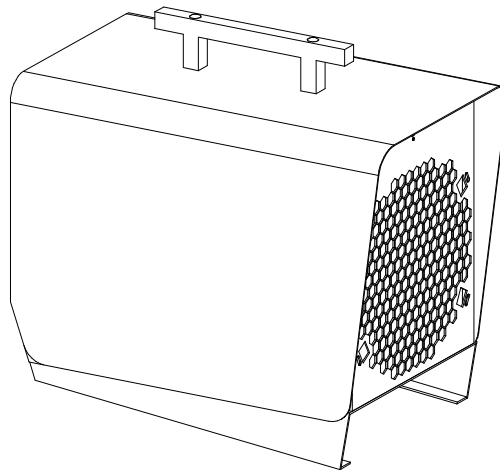

REMKO TX 9000

Electric Heaters



Operation
Technology
Spare Parts

Operating instructions

Make sure to read these instructions carefully before starting/using the unit!

**Our guarantee will become void when the unit supplied by us is used and installed for inadequate purposes, or maintained incorrectly, etc., or if it is changed without our prior consent.
Subject to alterations!**

Mobile Electric Heaters

CE

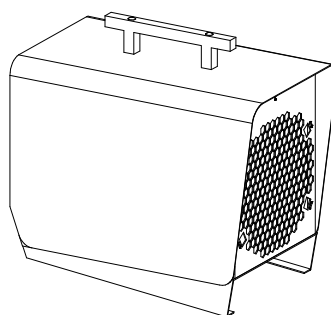

Contents	Page	Contents	Page
Safety Instructions	4	Troubleshooting	6
Description of device	4	Technical data	6
Starting	4	Wiring diagram	6
Unit shut down	5	Exploded view	7
Maintenance and service	5	Spare part list	7
Service and guarantee	5		



Always keep these operating instructions near or on the unit!



Safety Instructions

REMKO electric heaters will provide you with high utility and long life thanks to our extensive material, function and quality controls. Dangers may arise nevertheless if the unit is used by persons not familiar with its operation or if the unit is not used for its intended purpose.

Please pay attention to the following points:

- ◇ The persons charged with the operation of the units have to check these before starting work as to visible defects of the operation and safety devices, as well as to make sure that no protective devices are missing. *In the case of faults the supervisor is to be informed.*
- ◇ In the case of faults which endanger the safe operation of the units, the units are to be stopped!
- ◇ During the operation of the units the applicable local regulations are to be observed and the relevant safety measures to be taken.
- ◇ Make sure that the prescribed safety distances from combustible objects are observed!
- ◇ A free air suction and air discharge must be ensured
- ◇ The blow off opening of the unit may not be narrowed or equipped with hoses or conduits.
- ◇ Never place foreign objects into the unit.
- ◇ Do not cover the units during operation.
- ◇ The units may not be operated near bath tubs, showers, swimming pools, etc.
- ◇ The units may not be operated directly beneath a wall socket.
- ◇ The units may not be exposed to direct water jets.
- ◇ Make sure that no water penetrates inside the units.
- ◇ The units may not be operated in rooms which are endangered by explosions.
- ◇ Protect all electric cables outside the units from damage (e.g. caused by animals).

 **The electric connection of the units is to be carried out via a special supply point with fault current safety switch.**

Description of Device

The units are operating with electric energy and are suitable for a fully automatic, all-purpose and simple application.

The units are equipped with capsuled electrical heating elements, room thermostat, noiseless maintenance-free axial fans, safety and after-cooling thermostat, 3-stage operating switch.

The units are in accordance with the basic safety and health requirements of the relevant EC – regulation.

The units are handled simply and are safe in operation.

Application

- ◇ Drying of new buildings, spot heating of working places outside or in fire-proof halls and production places.
- ◇ Permanent or temporary heating of rooms.
- ◇ Defrosting of machines vehicles and fire-proof storing goods with keeping the prescribed distance of safety.

Working of device

The units are equipped with a 4-stage operating switch.

In the first stage only the supply air fan is operated and the units can be used for air circulation.

In the 2nd – 3th. stage the heating elements are activated and hot air is discharged.

The units are operated with a room thermostat to ensure a constant room temperature. When the pre-selected temperature has been reached, the thermostat stops the heating operation to restart it when the temperature has fallen below the set value.

When the units have been switched off by the operating switch or the room thermostat, the supply air fan continues running for a certain time to cool down the heat exchanger, and then it stops automatically.

 **Never interrupt (except in emergency situations) the connection to the mains before the end of the whole after-cooling phase.**

Starting

A well trained person is to be charged with the operation and control of the units.

1. Check the main voltage is in accordance with the unit voltage.
400V / 3~, PE / 50 Hz.

2. Put operating switch into position "0".

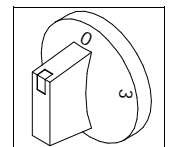

3. Connect the CEE-unit plug with an extension cable according to the regulations to an adequate CEE-mains socket.

 **Connecting cable extensions may be laid exclusively by authorised electricians based on the unit capacity, cable length and taking the local terms of use into account.**

Heating

The unit runs fully automatically and is dependent on set temperatures.

If the temperature at the blower aperture rises above 80° C the heating operation is stopped and will restart after the cooling-down period automatically.

1. Pre-select desired room temperature on the room thermostat.

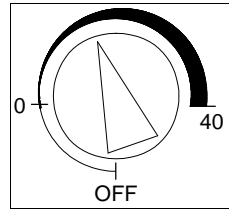

2. Put operating switch into desired position (2 or 3) depending on the desired heating capacity.

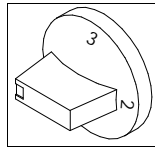

 **For optimum unit operation, the device should not be operated at an ambient temperature above 25 °C.**

Ventilation

In this position only the supply air fan runs. The thermostat regulation and the heating operation is not possible

1. Put operating switch into position "1"
Ventilation

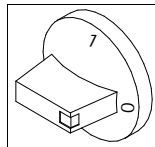

Unit Shut Down

1. Put operating switch into position "0".
OFF.

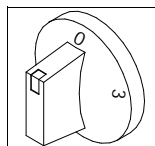

Attention, important hints to the after-cooling phase.

- ◇ The air supply fan continues running to cool down the unit and then stops later.
Fan can start several times before final switching off.
- ◇ Never interrupt (except in emergency situations) the connection to the mains before the end of the whole after-cooling phase.

 **Our guarantee does not cover damages caused to the unit by overheating.**

Maintenance and Service

Regular maintenance and the observation of some basic principles is important to ensure a long service life and a trouble-free operation of the unit.

 **Prior to starting any work make sure to pull the mains plug out of the mains socket!**

Please pay attention to the following points:

- ◇ The unit is to be maintained and cleaned in regular intervals.
- ◇ The unit is to be kept free from dust and other deposits and is to be cleaned only with a dry or humid cloth.
Do not use water jet.
- ◇ Do not use any aggressive cleaning agents or those which are harmful or environmentally unfriendly.
- ◇ Do not use cleaning agents which contain solvents.
- ◇ Only use suitable cleaning agents to remove extreme dirt.
- ◇ Check safety devices regularly.
Check protective suction and blower grids regularly and clean, when necessary.
- ◇ Do not damage the sensor and capillary tube of the thermostat when the rear panel is installed or removed.
- ◇ According to the terms of use the units are to be checked as to their perfect operation by an expert when necessary, but at least once a year.
- ◇ Please carry out an electrical safety test after having finished service on the unit.

Service and Guarantee

Any claims under guarantee regarding materials can be accepted only when the orderer or his customer has filled in completely the "guarantee certificate" which is enclosed with every REMKO-heater and has returned it to REMKO GmbH & Co. KG in due time after the unit's sale and commissioning. The units are factory tested on faultless function. If any failures occurs though which cannot be eliminated by the operating person, please contact your dealer or contact person.

 **An operation/use other than that indicated in these instructions is prohibited!**

 **In the case of non-observation we will not be held responsible and our guarantee will become void.**

Correct usage

The units are to be used only for heating and ventilation purpose in industrial or commercial application because of their construction and equipment. If specification of the manufacturer or legal regulations, are not followed or if unauthorised changes are made on the unit, the manufacturer is not liable for resulting damages.

Troubleshooting

 Prior to starting any work make sure to pull the mains plug out of the mains socket!
Setting and maintenance is to be carried out only by authorised experts!

Unit (fan) does not start:

1. Check main fuse
2. Check connecting cable with plug
3. Check operating switch
4. Check slight drifting of fan (motor)

Unit does not heat

1. Check operating switch
2. Check function of the two temperature limiters.
4. Check room thermostat
5. Check room thermostat-operation: thermostat must be set higher than the room temperature

Should the unit still not be working despite these checks, please contact an authorised service centre.

Technical Data

Series	TX9000		
Nominal heat output	kW	9,0	
Switchable heat output	kW	2 x 4,5	
Air output	m ³ /h	600	
Electrical connection	V	400, 3~, PE	
Frequency	Hz	50	
Rated current max.	A	13,2	
Power consumption max.	kW	9,15	
Fuse protection (required)	A (inert)	16	
Sound pressure level L _{pA} 1m ¹⁾	dB (A)	53	
Dimensions	Length	mm	510
	Width	mm	300
	Height	mm	455
Weight	kg	14,7	

1) noise measuring DIN 45635 - 01 - KL 3

Wiring Diagram

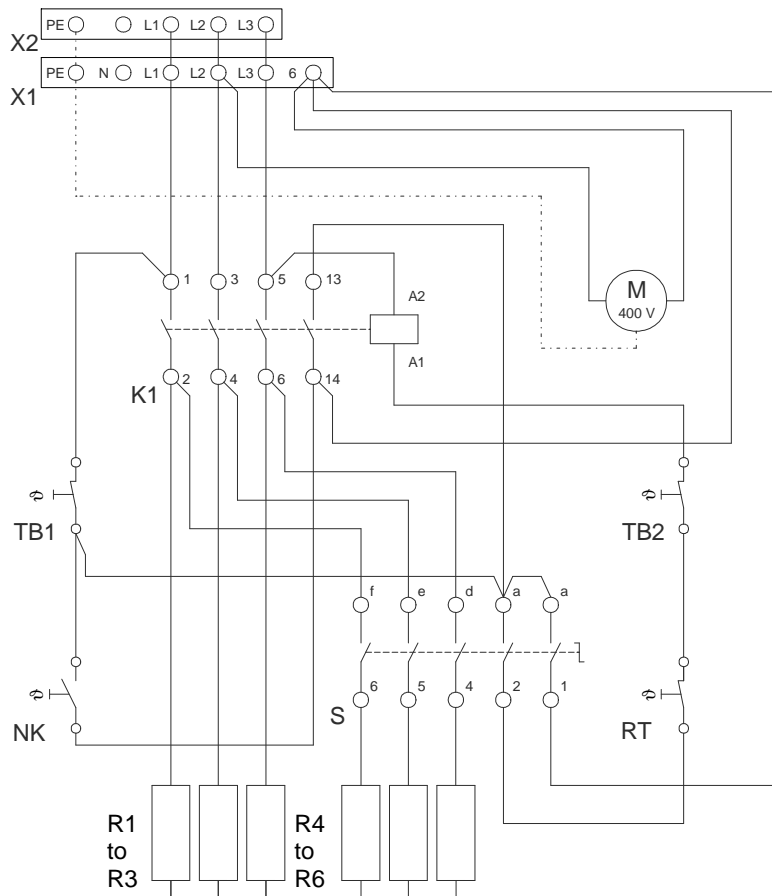

- K1 contactor
- M fanmotor (400 V)
- NK recool thermostat (37°C)
- R1 to R3 heating elements 1. step
- R4 to R6 heating elements 2. step
- RT room thermostat
- S operating switch
- TB1 temperature limiter (77°C)
- TB2 temperature limiter (70°C)
- X1 terminal strip
- X2 CEE-mains plug

schematic diagram operating switch

S	0	1	2	3
a-1		×	×	×
a-2			×	×
d-4				×
e-5				×
f-6				×

We reserve the right to make modifications in dimensions and construction in the interests of technical progress.

Exploded View

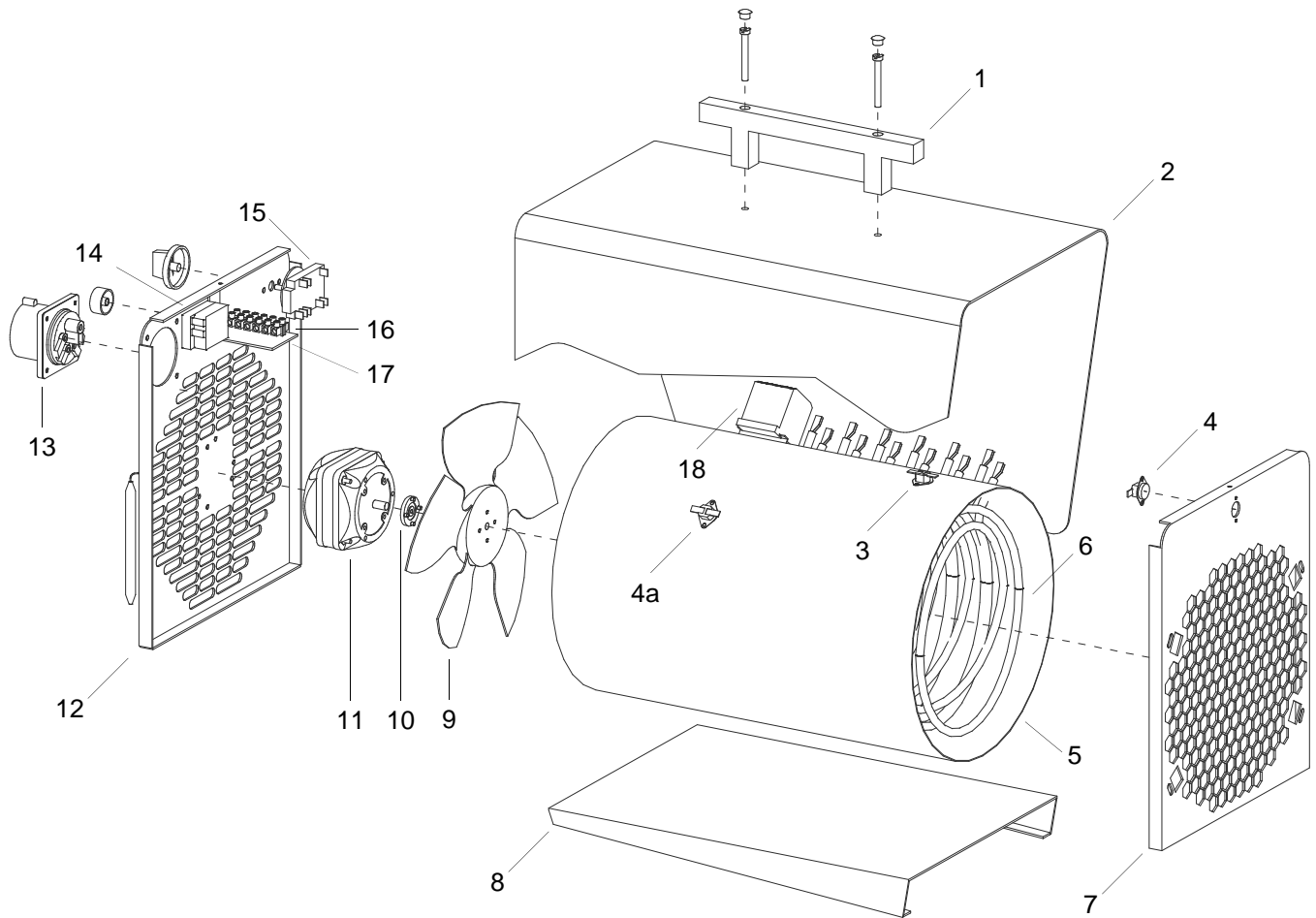

Spare Part List

Nr.	Description	Ref.-No.
1	transport handle	1101142
2	outside casing	1101080
3	recool thermostat	1104065
4	temperature limiter 77 °C	1101161
4a	temperature limiter 70 °C	1101081
5	inside casing	1101082
6	heating element (1 from 6)	1101083
7	front panel	1101084
8	base plate	1101085
9	fan blade	1101086
10	clutch plate	1108014
11	fan motor (400 V)	1101087
12	rear panel	1101088
13	CEE-mains plug	1101089
14	room thermostat with sensor	1101066
15	operating switch	1101090
16	terminal strip, 6 fold	1101366
17	angle support	1101091
18	contactor	1101092
not shown	protection socket, small	1101304
	CEE-connecting cable with plug and socket, 5 meter	1011215

We reserve the right to make modifications in dimensions and construction in the interests of technical progress.

REMKO GmbH & Co. KG
Klima- und Wärmetechnik

D-32791 Lage • Im Seelenkamp 12
D-32777 Lage • PO Box 1827
Phone +49 (5232) 606 - 0
Fax +49 (5232) 606260