

REMKO MKT

MKT 290, MKT 290 S-Line

Mobile Air Conditioner

Operation · Technology · Spare Parts



Contents

<i>Safety notes</i>	4
<i>Environmental protection and recycling</i>	4
<i>Warranty</i>	4
<i>Intended use</i>	4
<i>Transport and packaging</i>	5
<i>Equipment description</i>	5
<i>Operation</i>	6-7
<i>Bevore Commissioning</i>	8-9
<i>Commissioning</i>	9
<i>Shut-down</i>	9-10
<i>Care and maintenance</i>	10
<i>Installation scheme of the wall through (optional)</i>	11
<i>Troubleshooting and customer service</i>	12
<i>Electrical connection diagram</i>	13
<i>Exploded view</i>	14
<i>Spare parts lists</i>	15
<i>Technical data</i>	16
<i>EC-Declaration of conformity</i>	17





Read these operating instructions carefully before commissioning / using the device!

These instructions are an integral part of the system and must always be kept near or on the device.

This operating manual is a translation of the German original.

Subject to modifications; no liability accepted for errors or misprints!

Safety notes

Carefully read the operating instructions before commissioning the equipment for service. It provides useful tips and information  as well as hazard warnings to prevent injury or material damage . Failure to follow the directions in this manual can result in endangerment to persons, the environment and the equipment itself and will void any claims for liability.

- Keep this manual and the refrigerant data sheet near the unit.
- The unit should be set up and installed only by qualified personnel.
- The set-up, connection, and operation of the unit and its components must be in accordance with the operating conditions stipulated in this manual and comply with all applicable local regulations.
- Mobile units must be set up securely on suitable surfaces and in an upright position. Stationary units must be permanently installed for operation.
- Modification of equipment and components supplied by REMKO is not permitted and can cause malfunctions.
- Equipment and components may not be operated in areas where there is an increased risk of damage. Observe the minimum clearances.
- The electrical supply is to be adapted to the requirements of the equipment.
- The operational safety of equipment and components is only assured if they are fully assembled and used as intended. Safety devices may not be modified or bypassed.

- Do not operate equipment or components with obvious defects or signs of damage.
- All housing parts and openings in the device, e.g. air inlets and outlets, must be free of foreign objects, fluids, or gases.
- The equipment and components must be kept an adequate distance from flammable, explosive, combustible, abrasive and dirty areas or atmospheres.
- Touching some parts of the equipment can result in burns or other injury.
- Installation, repair and maintenance work may be carried out only by authorised specialists. Visual inspections and cleaning can be performed by the operator as long as power is disconnected from the equipment.
- To preclude any danger from the equipment, take appropriate hazard-prevention measures when performing installation, repair or maintenance work or cleaning the equipment.
- The equipment or components are not to be exposed to any mechanical stresses, extreme levels of humidity or direct sunlight.

Environmental protection and recycling

Disposal of packaging

All products are packed for transport in environmentally friendly materials. Make a valuable contribution to reducing waste and sustaining raw materials. Only dispose of packaging at approved collection points.

Disposal of equipment and components

Only recyclable materials are used in the manufacture of the devices and components.

Help protect the environment by ensuring that the devices or components (for example batteries) are not disposed in household waste, but only in accordance with local regulations and in an environmentally safe manner, e.g. using certified firms and recycling specialists or at collection points.



Warranty

Prerequisites for possible warranty claims are customer or his accepting representative has completely filled out the "warranty registration card" supplied with the unit and was completely filled out and returned to REMKO GmbH & Co. KG and placing the unit in service. The warranty conditions are listed in the "General terms and conditions". Furthermore, only the parties to a contract can strike special agreements beyond these conditions. For this reason please contact your contractual partner in the first instance.

Intended use

Depending on the model, the equipment and the additional fittings with which it is equipped is only intended to be used as an air-conditioner for the purpose of cooling or heating the air in an enclosed room. Different or additional use shall not be classed as intended use. The manufacturer/supplier assumes no liability for damages arising from an unintended use of the equipment. The user bears the sole risk in such cases. Using the equipment as intended also includes working in accordance with the operating manual and installation instructions and complying with the maintenance requirements.

Transport and Packaging

The equipment is shipped in sturdy transport packaging. Immediately check the equipment on delivery and make note of any damage or missing parts on the delivery note and inform the forwarding agent and your contractual partner. No warranty can be assumed for later claims.

Equipment description

The device is particularly suited for flexible operation. The mobile air conditioning unit is comprised for setting up on the floor indoors, and has an exhaust tube to dissipate the heat.

The indoor unit will be located in the room to be cooled. Heat in the evaporator (heat exchanger) is transferred to the internal cooling circuit. This is the heat of a further heat exchanger (condenser) via the flexible exhaust hose into the open again.

The condensate collected during cooling operation is transported to the outdoor unit by means of a condensate pump integrated into the indoor unit and evaporates via the heat exchanger. The device filters and dehumidifies the air and thereby creates a comfortable room climate. It works fully automatically and offers numerous additional options thanks to its microprocessor control system. The device can be conveniently operated by means of the infrared remote control unit included.

Front view



Rear view

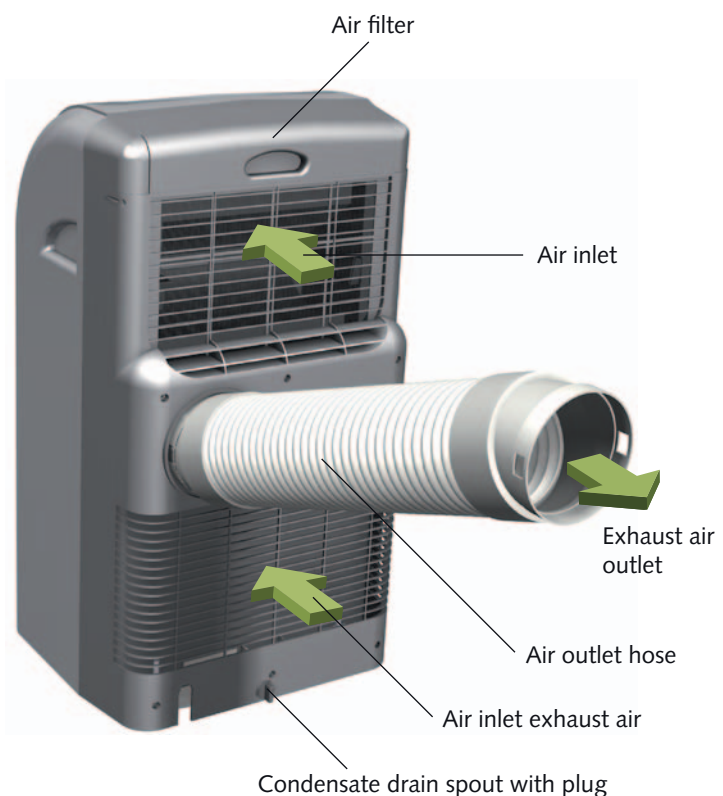

Operation

The system can be operated by means of the control panel on the device or via the standard infrared remote control unit. The functional operation of the buttons among themselves is identical, however, the designation can vary. The batteries must be correctly inserted before the infrared remote control is used.

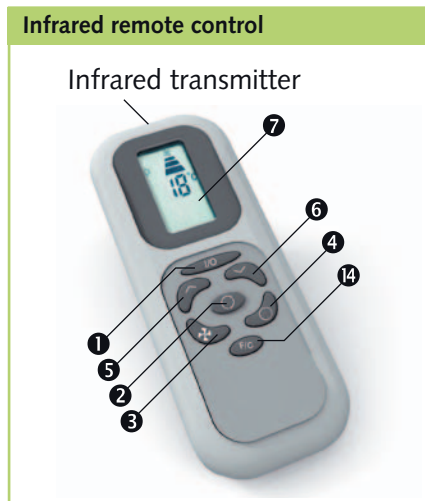
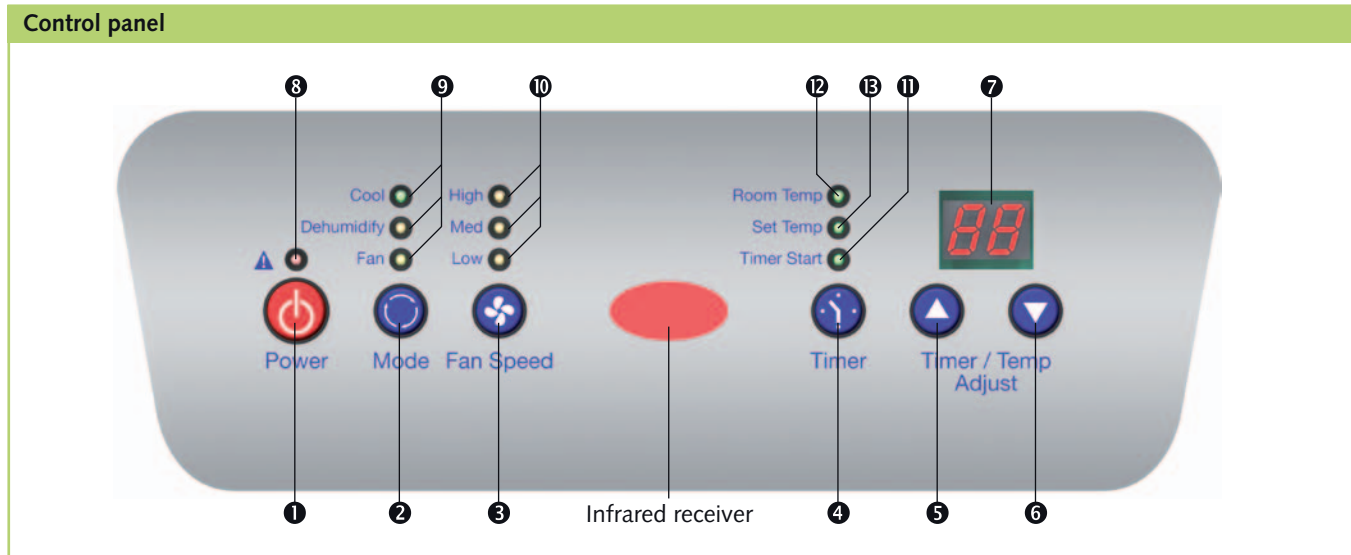

Legend

- 1 ON / OFF „Power“ button
- 2 „Mode“ button
- 3 „Fan Speed“ button
- 4 „Timer“ button
- 5+6 Temperature/time setting buttons
„Timer/Temp Adjust“:
5 higher, 6 lower

7 Display

8 Red fault LED: Reservoir full

An acoustic and an optical signal indicate that the float switch of the internal reservoir has shut down the operation of the device.

The acoustic signal dies down after a short period of time, but the LED remains active.

9 Mode LED display

Green: „Cool“
Orange: „Dehumidify“
Yellow: „Fan“

10 Orange LED display

for the fan speed, with high/medium/low speed
„High“/„Med“/„Low“

11 Green LED display for the time delay, „Timer“

12 Green „Room Temp“ LED

(If this LED lights up the current room temperature is shown in the display 7)

13 Green „Set Temp“ LED

14 „°C/°F“ toggle button

(only on the remote control)

„Mode“ selection

„Cool“

The device is used to cool the room. It filters and dehumidifies the air and thus creates a pleasant room climate.

„Dehumidify“

In the „Dehumidify“ mode, humidity is removed from the air.

„Fan“

The device circulates the air, filters it, and creates an even air flow.

„Cool“ mode

1. Attach the air outlet hose to the wall bushing or the window.
2. Activate the device using the “Power” button ❶
3. Press the “Mode” button ❷ until the “Cool” LED ❸ lights up.
4. Select the fan setting using the “Fan Speed” button ❸:
 - “High” highest speed
 - “Med” medium speed
 - “Low” lowest speed
5. If the “Room Temp.” LED ❷ lights up, the current room temperature is shown in the display ❸
6. As soon as the ❹/❺/❻ button is pressed, the display switches from the room temperature to the set temperature (LED ❷ lights up) and shows the desired temperature for 15 seconds.
7. Set the desired room temperature using the “Timer/Temp. Adjust” button ❺/❻. The up arrow ❺ increases the set value shown in the display ❸ while the down arrow ❻ decreases it.

„Dehumidify“ mode

1. Attach the air outlet hose to the wall bushing or the window.
2. Activate the device using the “Power” button ❶.
3. Press the “Mode” button ❷ until the “Dehumidify” LED ❸ lights up; the fan is automatically switched to the “Med” or medium fan speed stage.

„Fan“ mode

1. Activate the device using the “Power” button ❶.
2. Press the “Mode” button ❷ until the “Fan” LED ❸ lights up.
3. Select the fan setting using the “Fan Speed” button ❸:
 - “High” highest speed
 - “Med” medium speed
 - “Low” lowest speed
4. The room temperature is not influenced and remains constant. For this reason, the temperature and time setting “Timer/Temp. Adjust” buttons ❺/❻ cannot be used.

„Timer“ time delay

You can turn the device on and off automatically using the timer. To do so, an activation/deactivation delay is programmed.

Automatic activation

1. Activate the device using the “Power” button ❶.
2. Select the mode and make all settings for the desired mode.
3. Deactivate the device using the “Power” button ❶.
4. Press the “Timer” button ❹.
5. Set the time using the “Timer/Temp. Adjust” button ❺/❻. Only whole hours can be entered.
6. The LED ❷ flashes.
7. The device activates automatically at the set time.

Automatic deactivation

1. The device is running in the previously set mode.
2. Press the “Timer” button ❹.
3. Set the remaining run time using the “Timer/Temp. Adjust” button ❺/❻. Only whole hours can be entered.
4. The LED ❷ flashes.
5. The device deactivates automatically at the set time.



TIP

You can achieve a pleasant room climate by selecting a set temperature that is a maximum of 4 to 7°C below the outdoor temperature.

Bevore Commissioning

The device is placed at the desired location, with the outlet side to the room. Note the list the following information.

- Allow the device to the box at least 5 minutes stand on its transport wheels before operating it.
- Place the unit stable on a flat, stable surface. Uneven floors can cause vibration and unwanted noise.
- All extensions of the power line must have a correct cross section and may be used only fully rolled out.



- Never operate the unit without the intake filter. Without an air intake filter, the plate fins of the evaporators become dirty and the unit's performance is adversely affected.



- Make sure that people and objects, such as plants in the room, are not directly in the path of the expelled air.

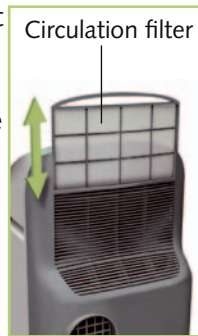

- Make sure that the deflector piece from the top slides down into the notches on the side until it clicks into places. To ensure that the unit operates effectively, do not place the flexible exhaust hose supplied at sharp angles and make sure there are no kinks.



- The air expelled from the unit contains a certain amount of moisture. We therefore recommend expelling the air to the surroundings or the outside.

⚠ CAUTION

From the back of the device to the back of the wall must be a minimum distance of about 20 cm.

💡 TIP

In case of direct sunlight, make sure to close all curtains and blinds. Keep doors and windows closed during operation.

- Check that the plug-in of condensation drain placed available and that is correct. There is a risk of uncontrolled condensate outlet is after commissioning.

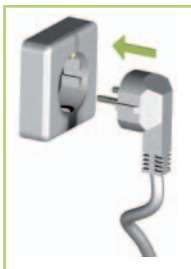

Expelling the warm air

⚠ CAUTION

The exhaust hose is always embarrassed with a pitch in air direction and should not be extended!

During cooling mode, the unit generates warm air. This air must be expelled from the room to retain the cooling effect.

It is therefore necessary to insert the supplied exhaust hose into the air outlet opening at the back of the unit.

Different ways of expelling air

You can expel air from the building as follows:

With a flat nozzle.

The flat nozzle supplied can be used in different ways. It is possible to guide the flat nozzle through the open window and secure it firmly using straps and suction devices. (Fig. 1, page 9).

The flat nozzle can also be hung through the partially opened window (Fig. 2, page 9).

Commissioning

Wall lead-through

The hose supplied is firmly connected to a wall lead-through. Lead-through kits can be purchased as accessories. (Fig. 3).

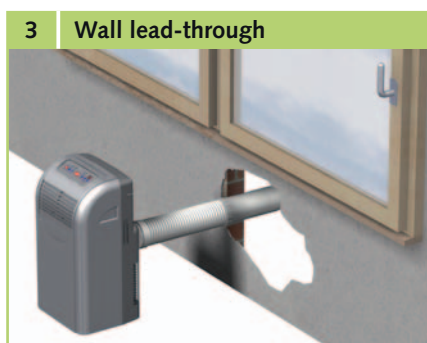
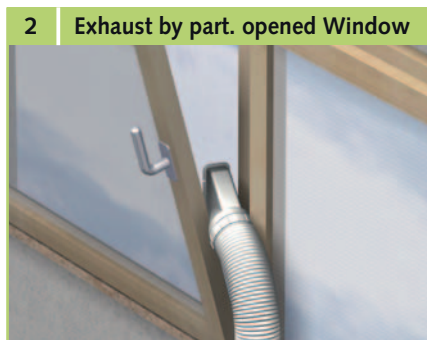

NOTE

In some circumstances, low pressure can occur in the setup room when air is being expelled via a permanently attached exhaust hose, e.g. as a result of closed windows or doors. If the performance of the unit is adversely affected as a result, make sure that the pressure is corrected

Prior to initial operation, the air intake and outlet openings must be inspected for foreign bodies and the air intake filter for dirt. Blocked or dirty grilles and filters must be cleaned immediately. See the chapter "Maintenance and Service".

Cooling mode

1. Switch the unit on with the "I/O" button. .
2. Select cooling mode with the "Mode" button.
The "AUTO" LED must be lit up.
3. Set the target temperature you want with the „TIMER/TEMP/ADJUST“ buttons.
The selected target temperature appears on the display.
If the set fan speed is too high or too low, the desired fan speed can be set by pressing the "FAN SPEED" button.

Fan mode (circulation)

1. Switch the unit on with the "I/O" button
2. Select fan mode with the "FAN SPEED" button.
The LED „HIGH/MED/LOW“ must be lit up.

Shut-down

Temporary Shut-down

If the unit is to be taken out of operation for a longer period of time, for example, over the winter, proceed as follows:

1. Let the device run for approximately 2 hours in circulation mode (FAN) to dry the surface of the evaporator plate fins. This removes the remaining moisture from the unit and prevents unpleasant odours when the device is put back into operation.
2. Switch off the unit by pressing the "I/O" button, unplug the unit from the power supply and roll up the power cord. Make sure that the cable is not bent and there are no kinks.
3. Place a suitable container under the condensation drain of the internal tank. The condensation drain is located at the bottom at the back of the unit.
4. Pull the plug from the condensation drain and collect the water that drains out.
5. Then replace the plug. Keep in mind that if there is no plug or it is inserted incorrectly, water may leak out after the unit has resumed operation.
6. Store the unit in an upright position in a dry location that is protected from direct sunlight and dust. To prevent dust from getting inside the unit, protect it with, for example, a plastic cover.

Permanent shut-down

The entire system should only be dismantled by a specialist firm familiar with all environmental aspects involved.

REMKO GmbH & Co. KG or your sales partner will be pleased to provide details of refrigerant specialists in your area.

Care and maintenance

Regular care and observation of some basic points will ensure trouble-free operation and a long service life of the unit.

CAUTION

Prior to performing any work, ensure the equipment is disconnected from the voltage supply and secured to prevent accidental switch-on!

- Clean the equipment using a damp cloth. Do not use a jet of water.
- Do not use any caustic, abrasive or solvent-based cleaning products.
- Only use suitable cleaning agents, even in the event of severe soiling.
- Make sure that no moisture gets into the device. Clean regularly and thoroughly, the exhaust air inlet and outlet openings. There is usually collected first on dirt.
- It is recommended that you take out a maintenance contract with an appropriate specialist firm.

Cleaning the filter

The unit is equipped with two air intake filters. These can be removed from the back of the unit. The filters must be cleaned at regular intervals. Clean the air filters after no more than 100 hours of operation. If the air is heavily contaminated, reduce this time period accordingly.

1. Switch the unit off with the On/Off button on the control panel.
2. Remove the filter from the unit. (Fig. 4).
3. Clean the dust that has accumulated from the filter. You can use a vacuum cleaner. (Fig. 5).
4. If the dust filter is very dirty, wash it with a lukewarm soap solution (Fig. 6).
5. Let the filter air dry.
6. Replace the filter in the unit. (Fig. 4).
7. Make sure that the filter is dry and undamaged.

CAUTION

Never operate the unit without the air filter.

4 Filter change



5 Cleaning with a vacuum cleaner



6 Cleaning with lukewarm water



Installation scheme of the wall through (optional)

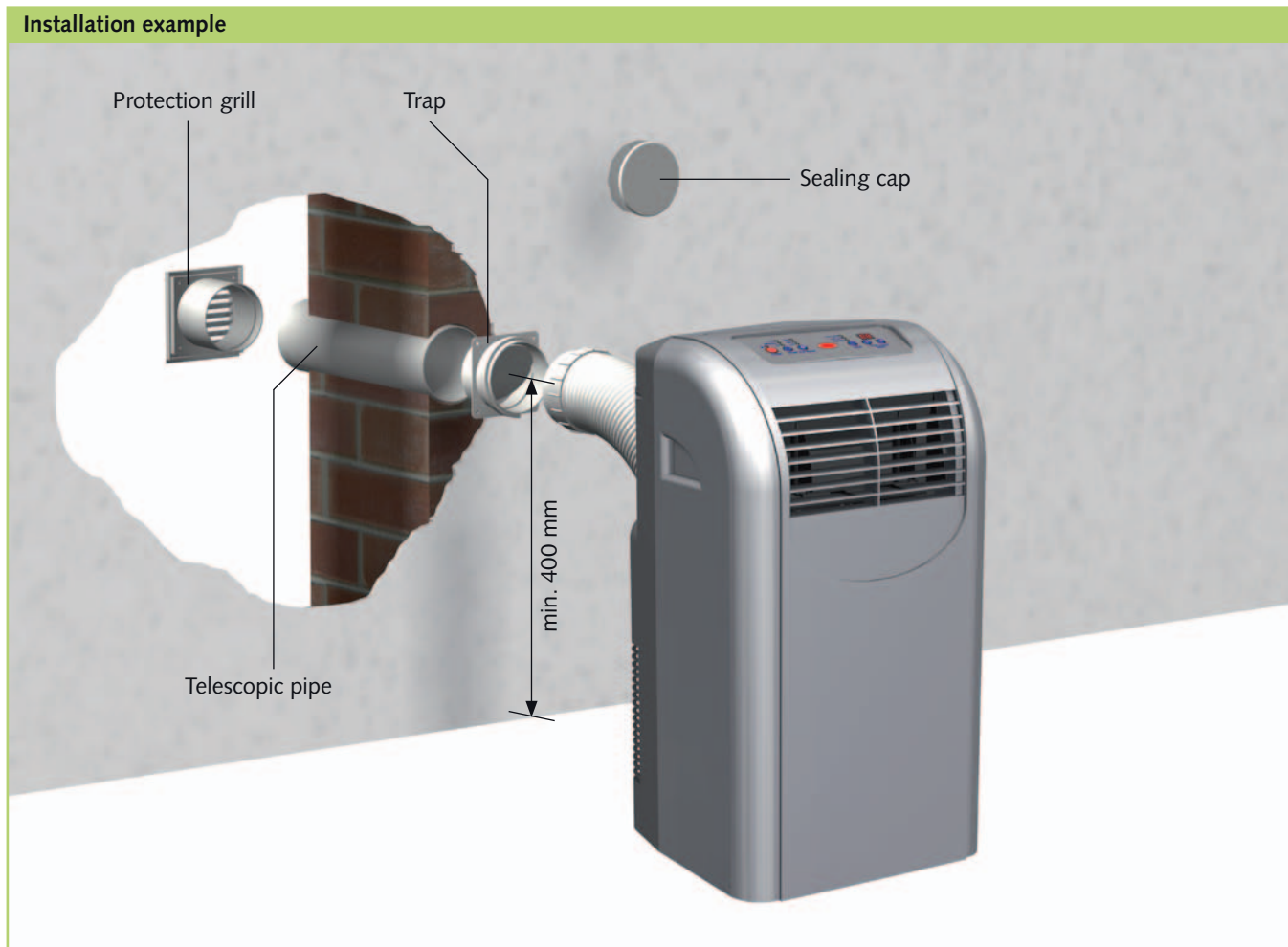

Installation Instructions

1. Create a core hole in the outside wall (max.- wall thickness of 480 mm) with a diameter of at least 135 mm.
Note possible supply lines in this area!
2. Insert the telescopic pipe in the created wall opening so that is the outer pipe (large diameter) on the inside wall.
To prevent cold bridges, insulate the telescopic pipe with suitable insulating material.
3. Wall the telescopic pipe into the core hole in such a way that it is flush to both sides of the wall.
4. Mount the protection grill on the outside of the wall with 4 screws (make sure it is protected from rain).
5. Fix the trap to the inside and mount it with 4 screws..
The "top" label on the trap must be legible from the inside!
6. When taking the device out of service, for example, at the beginning of winter, close the opening of the trap using the sealing cap to prevent air circulation.

Troubleshooting and customer service

The unit has been manufactured using state-of-the-art production methods and tested several times to ensure its correct function. If malfunctions should occur, please check the unit as detailed in the list below. If all functional checks have been carried out and the device still fails to operate properly, then please notify your nearest specialist dealer.

CAUTION

Never open the device housing.

The device is not functioning and the control panel remains dark.

- Make sure that
 - the mains plug is properly inserted;
 - there is no power failure;
 - the mains voltage is present (fuse)
- Check the mains supply line for damage.

NOTE

Contact your dealer or contractual partner if the device cannot be commissioned.

The device is not functioning and the "Timer" time delay LED is flashing.

- "Timer" time delay is programmed. Delete the timer setting.

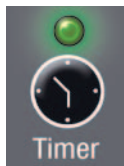

The device is not functioning and "E1" is being shown in the display

- The room temperature lies outside the operating range of 16 to 35°C. Wait until the room temperature lies in the working range (reduce the incident of sunlight and close windows and doors, if necessary).



The device deactivates automatically. The fault LED flashes and a signal sounds (reservoir full).

To drain the reservoir, proceed as follows:

1. Switch off the device and pull the mains plug.
2. Place a flat tray under the condensate drain spout and remove the plug.
3. After the condensate has drained, reinsert the plug firmly.

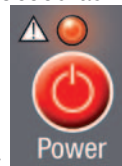

The device does not react to the remote control.

- Make sure that
 - the batteries are functioning; change them if necessary;
 - the batteries are inserted with the correct polarity (cf. the marking);
 - there are no objects between the remote control and the device (reach of approx. 5 m).

Condensate is emerging.

- Make sure that
 - the device is on a horizontal foundation;
 - the air outlet hose is properly attached;
 - the plug is firmly inserted in the condensate drain spout.

CAUTION

Never perform work on the cooling circuit or the electrical equipment..

The device is not cooling properly.

- Check the mode: the "Cool" LED must be lit.
- For an optimum cooling capacity, close the curtains and blinds. In addition, make sure the windows and doors are closed.
- Make sure that
 - the air outlet hose has been properly attached. It may not be bent, declining, or laid in a tight curve;
 - no foreign bodies impair the exhaust or intake air supply (observe the minimum clearances);
 - the air directing plate fins are free of soiling or foreign objects
 - the set temperature is not too high (operating limits of the device: 16 to 35°C).

Electrical connection diagram

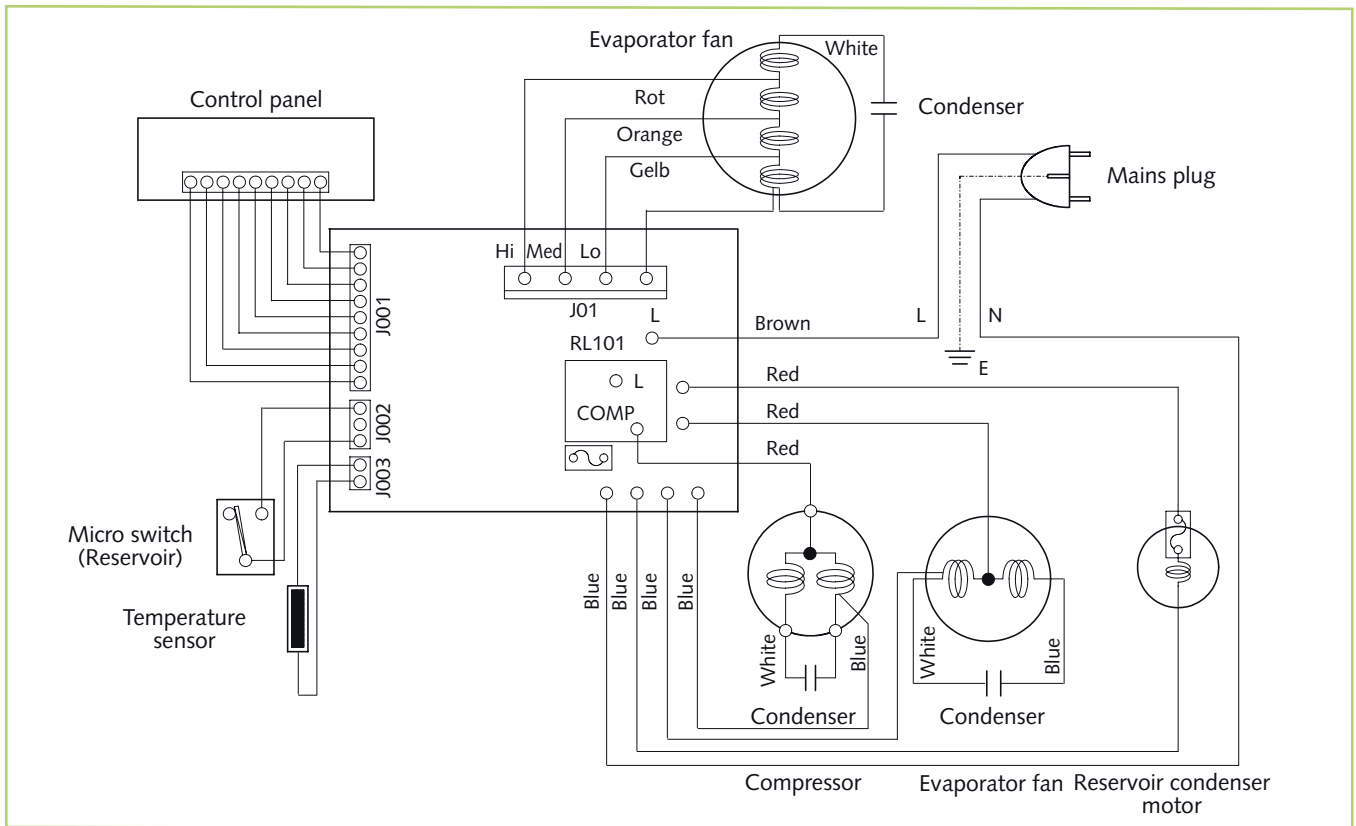

REMKO MKT

Exploded view



We reserve the right to modify the dimensions and constructional design as part of the ongoing technical development process.

Spare parts list

No.	Designation	MKT 290	MKT 290 S-LINE
	From series number	77285001	77285001
1	Unit bottom	1106850	1106850
2	Transport roller	1106851	1106851
3	Condensate pump	1106852	1106852
4	Condenser 2.5 μ F (evaporator fan)	1106853	1106853
5	Float regulator (reservoir)	1106854	1106854
6	Cover (reservoir)	1106855	1106855
7	Microswitch (reservoir)	1106856	1106856
8	Compressor, cpl	1106898	1106898
9	Condenser 40 μ F (compressor)	1106892	1106892
10	Evaporator	1106895	1106893
11	Fan housing (exhaust air)	1106860	1106860
12	Fan wheel (exhaust air)	1106861	1106861
13	Fan motor (exhaust air)	1106863	1106863
14	Condensate tray	1106824	1106824
15	Exhaust air pipe adapter	1106865	1106865
16	Condenser 1,5 μ F	1106866	1106866
17	Evaporator	1106896	1106896
18	Fan housing (circulation air)	1106822	1106822
19	Fan wheel (circulation air)	1106823	1106823
20	Fan motor (circulation air)	1106843	1106843
21	Circuit board	1106873	1106873
22	Mains supply line with plug	1106874	1106874
23	Front wall	1106820	1106827
24	Back wall	1106829	1106829
25	Air outlet segment	1106844	1106844
26	PCB with control	1106825	1106825
27	Control panel	1106826	1106831
28	Air filter	1106830	1106830
29	Entry circuit	1106886	1106833
30	Connection pipe adapter	1106887	1106834
31	Window jet	1106888	1106835
32	Condensate drain spout with plug	1106882	1106882
33	Remote control	1106884	1106884
	Air outlet hose, cpl. (nr. 29; 30; 31)	1106885	1106832
Spare parts without Abbildung			
	Sensor (circulation air)	1106889	1106889

Accessories

No.	Designation	MKT 290	MKT 290 S-LINE
	Wall bushing	1613115	1613115

When ordering spare parts, please state the computerised part no., unit number and type (see identification plate)!

Technical Data

Device type		MKT 290	MKT 290 <i>S-LINE</i>
Operating mode		Mobile Air Conditioning Unit for cooling	
Nominal cooling capacity ¹⁾	kW	2,94	
Energy efficiency class, cooling		A	
Energy efficiency factor EER ¹⁾		2,69	
Application range (room air volume), approx.	m ³	80	
Temperature setting range	°C	+16 up to +32	
Temperature operating limits	°C / %r.F.	+16 bis +35 / +35 bis +85	
Refrigerant		R 410A	
Operating pressure max., cooling circle	kPa	1800 / 3600	
Refrigerant quantity	kg	0,65	
Circulation air volume flow rate	m ³ /h	240 / 270 / 320	
Sound pressure level ²⁾	dB(A)	45 / 50 / 53	
Voltage supply	V/Hz	230 / 1~ / 50	
Type of protection	IP	20	
Power consumption ¹⁾	kW	1,09	
Current consumption ¹⁾	A	4,93	
Electrical starting current	A	21	
Air outlet hose, diameter	mm/mm	1200 / 125	
Diemnsions Height	mm	700	
Width	mm	435	
Depth	mm	430	
Weight	kg	32,0	
Color		white	silver
Serial no.		772...	773...
Ref.no.		1612290	1612291

1) Room temperature TK 35°C / FK 24°C

2) Distance 1 m

EC – Declaration of Conformity

(in accordance with Machinery Directive appendix II 1A -
Original declaration of conformity)



We do hereby declare that the devices named below, produced and sold by us, satisfy the relevant basic requirements of the EC guidelines, the EC safety standards and other product-specific EC standards.

Name of Manufacturer: **REMKO GmbH & Co. KG**
Air conditioning and heating technology
Im Seelenkamp 12
D - 32791 Lage

Name of CE representative: **REMKO GmbH & Co. KG**
Air conditioning and heating technology
Im Seelenkamp 12
D - 32791 Lage

Equipment (machinery) - Implementation: Mobile Air Conditioning Unit for cooling

Series / Model: REMKO MKT 290, MKT 290 S-Line
Series / Class Number: 772..... and 773.....

Applicable regulations : (EC-Directive)	MA - RL 2006/42/EC	Machinery Directive
	NS - RL 2006/95/EC	Low-Voltage Directive
	EMC – RL 2004/108 EEC	EMC Directive
	EnVKV - RL 92/75/EEC	Energy consumption labelling directive
	EC 97/23/EC	Pressure Equipment Directive

Applicable Standards: DIN EN ISO 12100-1-2 : 2004-04; DIN EN ISO 13857,
EN 14511 T1-4;
DIN 45635 - 1;
EN 378 – 1-4;
EN 55014 - 1; EN 55014 - 2; EN 55104
EN 60204 - 1; EN 60335 - 1; EN 60335 - 2 - 40;
EN 61000 - 3 - 2; EN 61000 - 3 - 3;

Lage, 25.02.10

REMKO GmbH & Co. KG

.....
Signature Product Manager

Notes

A series of 18 horizontal light green bars, stacked vertically, intended for writing notes. Each bar is a solid, uniform light green color and spans the width of the page.

REMKO INTERNATIONAL

*... und einmal ganz in Ihrer Nähe!
Nutzen Sie unsere Erfahrung und Beratung*



REMKO GmbH & Co. KG **Air conditioning and heating technology**

Im Seelenkamp 12 D-32791 Lage
Postfach 1827 D-32777 Lage
Telephone +49 5232 606-0
Telefax +49 5232 606-260
E-mail info@remko.de
Website www.remko.de

Hotline

**Air conditioning and
heating technology**
+49 5232 606-0

Export

+49 5232 606-130

Die Beratung

Durch intensive Schulungen bringen wir das Fachwissen unserer Berater immer auf den neuesten Stand. Das hat uns den Ruf eingetragen, mehr zu sein als nur ein guter, zuverlässiger Lieferant: REMKO, ein Partner, der Probleme lösen hilft.

Der Vertrieb

REMKO leistet sich nicht nur ein gut ausgebautes Vertriebsnetz im In- und Ausland, sondern auch ungewöhnlich hochqualifizierte Fachleute für den Vertrieb. REMKO-Mitarbeiter im Außendienst sind mehr als nur Verkäufer: vor allem müssen sie für unsere Kunden Berater in der Klima- und Wärmetechnik sein.

Der Kundendienst

Unsere Geräte arbeiten präzise und zuverlässig. Sollte dennoch einmal eine Störung auftreten, so ist der REMKO Kundendienst schnell zur Stelle. Unser umfangreiches Netz erfahrener Fachhändler garantiert Ihnen stets einen kurzfristigen und zuverlässigen Service.

