

REMKO MVT

MVT 600 DC, MVT 900 DC, MVT 950 DC, MVT 1050 DC

Inverter multisplit outdoor units

Operation · Technology · Spare parts

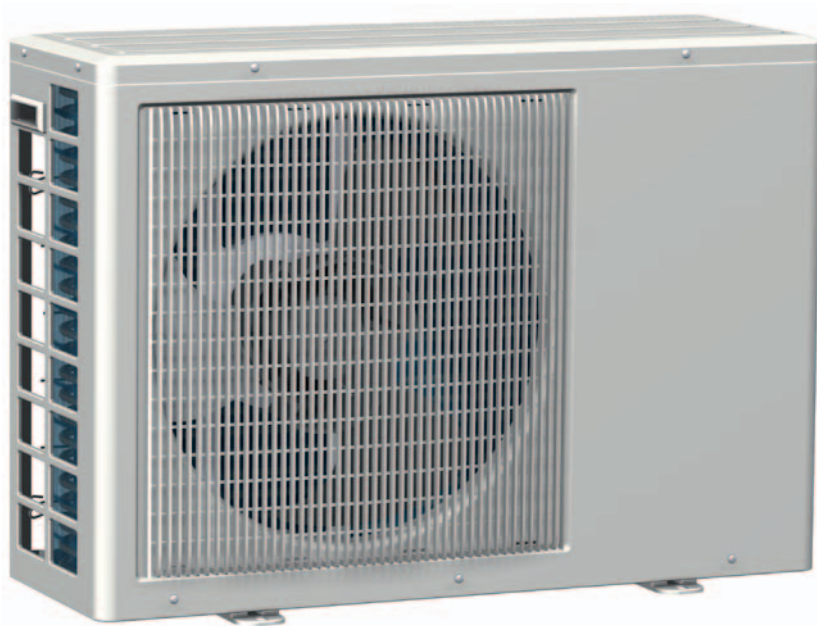

Contents

<i>Safety notes</i>	4
<i>Environmental protection and recycling</i>	4
<i>Warranty</i>	4
<i>Intended use</i>	5
<i>Transport and packaging</i>	5
<i>Description of the equipment</i>	5-6
<i>Combinations</i>	7-8
<i>Operation</i>	9
<i>Shutdown</i>	9
<i>Care and maintenance</i>	9
<i>Troubleshooting and customer service</i>	10-11
<i>Installation instructions for qualified personnel</i>	12-14
<i>Installation</i>	14-15
<i>Tightness check</i>	16-17
<i>Electrical connection</i>	16
<i>Electrical circuit diagram</i>	17-18
<i>Electrical connection diagram</i>	19
<i>Before commissioning</i>	20
<i>Add refrigerant</i>	20
<i>Commissioning</i>	20-22
<i>Unit dimensions</i>	23
<i>Exploded views</i>	24
<i>Spare parts lists</i>	24
<i>Technical data</i>	25-26
<i>EC – Declaration of Conformity</i>	27





These operating instructions should be read carefully prior to commissioning / operation of the equipment!

**These instructions are part of the equipment and must always be kept in the vicinity of the installation or on the equipment
This operating manual is a translation of the German original.**

Subject to modifications; No liability accepted for errors or misprints!

Safety notes

Carefully read this manual before starting the unit for the first time. It contains useful tips, information  as well as hazard warnings to prevent injury or material damage . Non-observance of this manual may endanger persons, the environment as well as the equipment itself and will void any claims for liability.

- Store this manual as well as the refrigerant datasheet in the vicinity of the unit.
- The unit should only be set up and installed by qualified personnel.
- The setup, connection and operation of the unit and its components must be in accordance with the operating conditions stipulated in this manual and comply with all applicable local regulations.
- Units designed for mobile use should be safely set up on a suitable floor and in a vertical position. Units designed for stationary use should only be operated in their permanently installed state.
- It is prohibited to make modifications or changes to equipment or components supplied by REMKO as this may cause malfunctions.
- Equipment and components should not be operated in areas where there is a heightened damage risk. Observe the minimum clearances.
- The electrical supply should be adapted to fulfil the requirements of the unit.
- The operational safety of equipment and components is only assured providing they are used as intended and in a fully assembled state. Safety devices should not be modified or bypassed.
- Do not operate equipment or components with obvious defects or signs of damage.
- All housing parts and openings, e.g. air inlets and outlets, must not be blocked by foreign items, fluids or gases.
- The equipment and components must be kept in a safe distance from inflammable, explosive, combustible, aggressive and dirty areas or atmospheres.
- Persons coming into contact with equipment parts may suffer burns or injury.
- Installation, repair and maintenance work should only be carried out by authorised specialists. Inspection and cleaning can be performed by the operator providing the equipment is not under voltage.
- Take appropriate hazard prevention measures when performing installation, repair or maintenance work or cleaning the equipment.
- The equipment or components should not be exposed to any mechanical stresses, extreme levels of humidity or direct exposure to sunlight.



Environmental protection and recycling

Disposal of packaging

All products are packed for transport in environmentally friendly materials. Make a valuable contribution to reducing waste and sustaining raw materials. Only dispose of packaging at approved collection points.



Disposal of units and components

For the manufacture of the units and components, only recyclable materials have been used. Help protect the environment by ensuring that the units or components (for example batteries) are not disposed in household waste, but only in accordance with local regulations and in an environmentally safe manner, e.g. through authorised disposal and recycling specialists or at collection points.

Warranty

Prerequisite for any warranty claims is that the purchaser or his client has completely filled out the "warranty registration card" and commissioning report included with the unit at the time when the equipment was purchased and commissioned and returned the completed card to REMKO GmbH & Co. KG.

The warranty conditions are listed in the "General business and delivery conditions. The contractual parties can also agree additional terms beyond the scope of the above. For this reason please contact your direct contracting partner first.

Intended use

Depending on the model, the equipment and the additional fittings with which it is equipped is only intended to be used as an air-conditioner for the purpose of cooling or heating the air in an enclosed room.

Different or additional use shall not be classed as intended use. The manufacturer/supplier assumes no liability for damages arising from an unintended use of the equipment. The user bears the sole risk in such cases.

Using the equipment as intended also includes working in accordance with the operating manual and installation instructions and complying with the maintenance requirements.

Transport and packaging

The equipment is shipped in sturdy transport packaging. Immediately check the equipment on delivery and make a note of any damage or missing parts on the delivery note. Inform the forwarding agent and contractual partner.

Warranty claims at a later date will not be accepted.

Description of the equipment

The outdoor unit serves to output the heat extracted by the indoor unit from the room being cooled. In heater operation, the heat taken up by the outdoor unit can be discharged by the indoor unit into the room to be heated. In both operating modes, the output produced by the compressor precisely matches requirements, and thereby regulates the nominal temperature with minimal temperature deviations. This "inverter-technology" enables power saving over a conventional split-system and also reduces noise emissions to a particularly low level. The outdoor unit can be installed outdoor or in indoor areas, providing certain requirements are met. The indoor unit is designed for installation high up on interior walls. It is operated via an infrared remote control.

The outdoor unit is comprised of a circuit containing a compressor, a liquefier with fin vaporisers, three electronic expansion valves and a liquefier fan. The outdoor unit is combinable with REMKO indoor units of series MXW in accordance with the cooling output (see chapter "Combinations"). The outdoor unit refrigerant circuit is controlled by the regulator in the indoor unit. In order to enable operation of the device at low outdoor temperatures, a thermal condenser pressure regulator serves as winter controller to regulate the speed of the liquefier fan.

Floor consoles, wall consoles and refrigerant pipes are available as accessories.

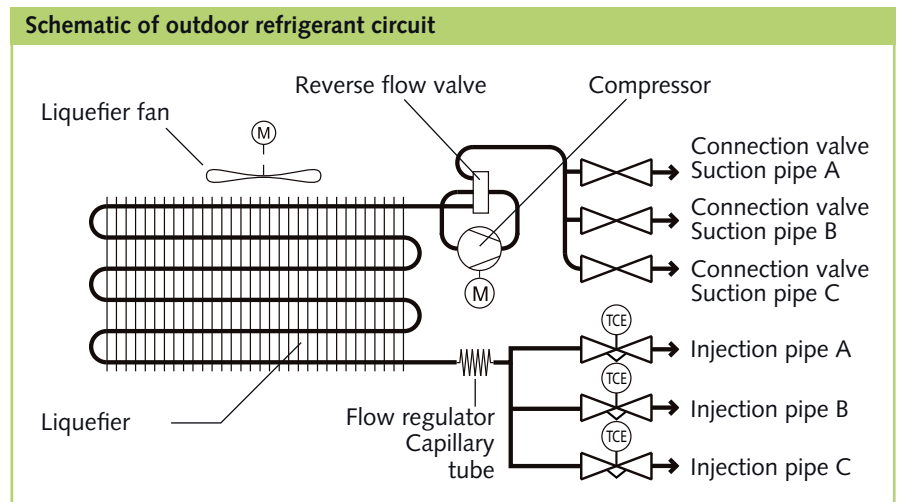

System design

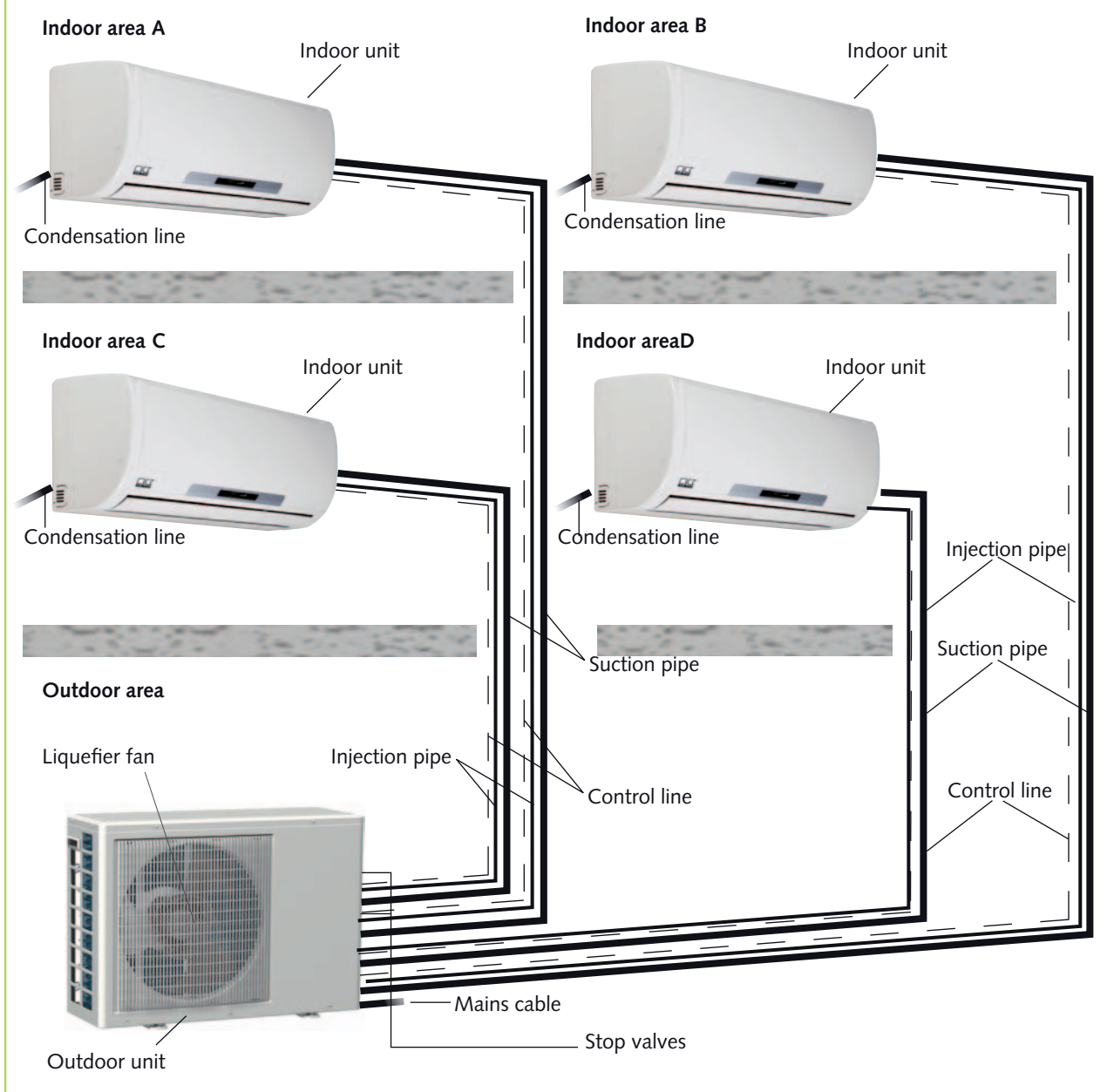

The connection between indoor units (A, B, C, D) and outdoor units (connection circuit A, B, C, D) of the outdoor unit is achieved with refrigerant pipes and a control line.

Combinations

Indoor units

The following indoor units can be used together with MVT series outdoor units:

Series MXW 200-520



Series MXD 200-520



Series MXT 260-520



The following combinations are possible:

Outdoor unit MVT 600 DC

	MXW / MXD / MXT			
	200	260	350	MXW 520
One indoor unit				
Combination 1	•			
Combination 2		•		
Combination 3			•	
Combination 4				•
Two indoor units				
Combination 5	• •			
Combination 6		• •		
Combination 7	•	•		
Combination 8	•		•	
Combination 9		•	•	
Combination 10	•			•

Outdoor unit MVT 900 DC

	MXW / MXD / MXT			
	200	260	350	MXW 520
One indoor unit				
Combination 1	•			
Combination 2		•		
Combination 3			•	
Combination 4				•
Two indoor units				
Combination 5	• •			
Combination 6		• •		
Combination 7	•	•	• •	
Combination 8	•	•		
Combination 9	•		•	
Combination 10	•			•
Combination 11		•		•
Combination 12			•	•
Three indoor units				
Combination 13	• • •			
Combination 14		• • •		
Combination 15	• •	•		
Combination 16	• •		•	
Combination 17	•	• •		
Combination 18	•	•	•	
Combination 19	•		• •	
Combination 20		• •	•	
Combination 21		•	•	
Combination 22	• •			•

Outdoor unit MVT 950 DC

	MXW / MXD / MXT			
	200	260	350	520
One indoor unit				
Combination 1	•			
Combination 2		•		
Combination 3			•	
Combination 4				•
Two indoor units				
Combination 5	• •			
Combination 6		• •		
Combination 7			• •	
Combination 8	•	•		
Combination 9	•		•	
Combination 10		•	•	
Combination 11	•			•
Combination 12		•		•
Combination 13			•	•
Combination 14				• •
Three indoor units				
Combination 15	• • •			
Combination 16		• • •		
Combination 17			• • •	
Combination 18		• •	•	
Combination 19	• •	•		
Combination 20	• •		•	
Combination 21	•	• •		
Combination 22	•	•	•	
Combination 23	•		• •	
Combination 24		•	• •	
Combination 25	• •			•
Combination 26	•	•		•
Combination 27	•		•	•
Combination 28		• •		•
Combination 29		•	•	•
Four indoor units				
Combination 30	• • • •			
Combination 31		• • • •		
Combination 32	• • •	•		
Combination 33	• • •		•	
Combination 34	• •	• •		
Combination 35	• •	•	•	
Combination 36	•	• • •		
Combination 37	•	• •	•	
Combination 38		• • •	•	
Combination 39	• •		• •	
Combination 40	•	•	• •	
Combination 41	• • •			•

Outdoor unit MVT 10050 DC

	MXW / MXD / MXT			
	200	260	350	520
One indoor unit				
Combination 1	•			
Combination 2		•		
Combination 3			•	
Combination 4				•
Two indoor units				
Combination 5	• •			
Combination 6		• •		
Combination 7			• •	
Combination 8	•	•		
Combination 9	•		•	
Combination 10		•	•	
Combination 11	•			•
Combination 12		•		•
Combination 13			•	•
Combination 14				• •
Three indoor units				
Combination 15	• • •			
Combination 16		• • •		
Combination 17			• • •	
Combination 18		• •	•	
Combination 19	• •	•		
Combination 20	• •		•	
Combination 21	•	• •		
Combination 22	•	•	•	
Combination 23	•		• •	
Combination 24		•	• •	
Combination 25	• •			•
Combination 26	•	•		•
Combination 27	•		•	•
Combination 28		• •		•
Combination 29		•	•	•
Combination 30	•			• •
Combination 31		•		• •
Combination 32			• •	•
Four indoor units				
Combination 33	• • • •			
Combination 34		• • • •		
Combination 35	• • •	•		
Combination 36	• • •		•	
Combination 37	• •	• •		
Combination 38	• •	•	•	
Combination 39	•	• • •		
Combination 40	•	• •	•	
Combination 41		• • •	•	
Combination 42	• •		• •	
Combination 43	•	•	• •	
Combination 44	• •	•		•
Combination 45	• •		•	•
Combination 46	• •			• •
Combination 47	•	• •		•
Combination 48	•	•	•	•
Combination 49	• • •			•
Combination 50		• • •		•
Combination 51	•		• •	•
Combination 52		• •	• •	
Combination 53		•	• • •	
Combination 54	•		• • •	

Operation

The compressor in the outdoor unit is operated by means of regulating the control board in the outdoor unit.

The chapter on "Regulation" in the manual for the outdoor unit must therefore be observed.

Shutdown

Temporary Shutdown

1. Allow the indoor unit to run for 2 to 3 hours in air circulation mode or in cooling mode at the maximum temperature setting in order to remove any residual moisture from the unit.
2. Shut down the system using the remote control
3. Switch off the voltage supply to the unit.
4. Cover as much of the unit as possible with plastic foil to protect it against the weather.

Permanent Shutdown

Ensure that equipment and components are disposed of accordance with local regulations, e.g. through authorised disposal and recycling specialists or at collection points.

Contact REMKO GmbH & Co. KG or your contract partner for local specialist companies near you.

Care and maintenance

Regular care, maintenance and observation of some basic points will ensure trouble-free operation and a long service life.

⚠ CAUTION

Prior to performing any work, ensure the equipment is isolated from the voltage supply and secured to prevent accidental switch-on!

Care

- Ensure the unit is protected against dirt, mould and other deposits.
- Clean the unit using a damp cloth. Do not use a jet of water.
- Do not use any caustic, abrasive or solvent-based cleaning products.

- When operating the fan, clean the fins of the unit prior to long shutdown periods.

Maintenance

- It is recommended that maintenance contract with annual maintenance interval with an appropriate specialist company.

💡 TIP

This ensures the operational reliability of your equipment!

💡 NOTE

The statutory regulations require an annual sealing test for the refrigerant circuit in relation to the refrigerant filling level. The inspection and documentation is to be carried out by corresponding specialist engineers.

Type of task	Commissioning	Monthly	Six-monthly	Yearly
Checks/Maintenance/Inspections				
General	●			●
Measure voltage and current	●			●
Function compressor	●			●
Check fan is functioning correctly	●			●
Dirt on liquefier	●	●		
Check refrigerant fill quantity	●		●	
Check condensation drain	●		●	
Test insulation	●			●
Check moving parts	●			●
Sealing test for refrigerant circuit	●			● 1)

1) see note

Troubleshooting and customer service

The unit has been manufactured using state-of-the-art production methods and tested several times to ensure its correct function. If malfunctions should occur, please check the unit as detailed in the list below. For installations with an indoor unit and outdoor unit, refer to the chapter "Troubleshooting and customer service" in both manuals. Please inform your dealer if the unit is still not working correctly after all the functional checks have been performed!

Malfunction

Fault	Possible cause	Check	Remedial measures
The unit does not start or switches itself off.	Power outage, undervoltage	Are all electrical installations functioning correctly?	Check voltage if necessary wait before switching back on
	Defective mains fuse Main circuit breaker is open	Are all lighting circuits functioning correctly?	Replace mains fuse Close main circuit breaker
	Damaged mains cable	Are all electrical installations functioning correctly?	Repair by a specialist
	Waiting time after switch-on too short	Is there a restart after approx. 5 minutes?	Schedule longer waiting periods
	Temperature outside operating range	Are the fans in the unit still working?	Observe the temperature ranges
	Occasional overvoltage or undervoltage	Check by a specialist	Turn the equipment off and back on
	Switch-off contact in external condensation pump has opened	Is the external condensation pump on the indoor unit "faulty"?	Clean the condensation pump drain Have the pump replaced
The unit is running with reduced or no cooling output.	Exchange refrigerant lines	Are the injection pipes and suction pipes of circuits A, B and C correspondingly connected?	Check by a specialist
	Exchange the electrical control cable	Are the control pipes and refrigerant pipes of circuits A, B and C correspondingly connected?	Check by a specialist
	Air inlet and/or air outlet are blocked by debris.	Debris in air inlet and air outlet area?	Clean the fins. Reduce the air resistance.
	Thermal or wind load was increased.	Have there been any constructional / application-related changes?	Reduce the thermal/wind loads by implementing appropriate measures.
	No heat output possible.	Is the fan on the outdoor unit running?	Fan / winter controller should be checked.
	Leaking refrigerant circuit	Are there signs of severe frost on the large stop valve?	Repair by a specialist.
The suction pipe and / or liquid separator on the compressor have iced up	Thermal load has increased	Is the outdoor unit running continuously?	Reduce the thermal load If necessary, install an additional device / insulate iced up components

Problem display by blinker code

Display	Cause	Required action
E0	EEPROM error	Switch off the power to device for 1 min. Contact specialist dealer
E1	Sensor suction pipe circuit 1 faulty / connection interrupted	Check the resistance of the sensor (at 20°C=12.6kΩ / 30°C=7.9kΩ)
E2	Sensor suction pipe circuit 2 faulty / connection interrupted	Check the resistance of the sensor (at 20°C=12.6kΩ / 30°C=7.9kΩ)
E3	Sensor suction pipe circuit 3 faulty / connection interrupted	Check the resistance of the sensor (at 20°C=12.6kΩ / 30°C=7.9kΩ)
E4	Sensor discharge liquefier faulty / connection interrupted	Check the resistance of the sensor (at 20°C=12.6kΩ / 30°C=7.9kΩ)
E5	Compressor voltage monitoring has tripped	Switch off the power to device for 1 min
E6	Sensor suction pipe circuit 4 faulty / connection interrupted	Check the resistance of the sensor (at 20°C=12.6kΩ / 30°C=7.9kΩ)
E7	Communication error between outdoor and indoor unit	Contact specialist dealer
P0	Excessive temperature (Klixon) compressor	Check refrigerant Check the resistance of the compressor sensor (normal 0Ω)
P1	High pressure sensor has responded	Check refrigerant filling level, check liquefier for soiling, check fan AT
P2	Low pressure sensor has responded	Check stop valve AT, check refrigerant, check electronic expansion valves,
P3	Overcurrent compressor has responded	Check winding resistance of the compressor (1Ω = U-V / U-W / V-W)
P4 LED AT flashes 9 times	Rotational speed monitoring on compressor has responded	Check compressor connections and PCB
P4 LED AT flashes 13 times	Rotational speed monitoring on compressor (inverter module) has responded	Check connections CN4, CN1 on the AT PCB Contact specialist dealer
P5	Excess temperature sensor on outdoor unit unit has responded	Exterior temperature > 1h under -15°C
P6	Sensor outlet liquefier has responded (Condensation temperature over 65°C)	Clean liquefier Reduce air inlet temperature

Installation instructions for qualified personnel

Important information prior to commissioning

NOTE

Label the refrigerant pipes (injection and suction pipes) as well as the associated electrical control lines of each interior unit with a letter. Only connect the lines to their associated connections.

- Observe the manuals for the indoor unit and outdoor unit when installing the entire system.
- Transport the unit in its original packaging as close as possible to the installation location. This avoids transportation damage.
- Check the contents of the packaging for completeness and check the unit for visible transport damage. Immediately notify any deficiencies to the contractual partner and forwarding agent.
- Lift the unit at the corners and not by the refrigerant or condensation connections.
- The refrigerant pipes (injection and suction pipe), valves and connections to make them tight against vapour diffusion. If necessary, also insulate the condensation line.
- Select an installation location which allows air to freely flow through the inlet and outlet (see section "Minimum clearances")
- Do not install the unit in the immediate vicinity of devices with intensive thermal radiation. Installation near thermal radiation reduces the unit output.

- Only open the stop valves for the refrigerant pipes after installation has been fully completed.
- Seal off open refrigerant pipes with suitable caps or adhesive strips to avoid the infiltration of moisture and never kink or compress the refrigerant pipes.
- Avoid unnecessary bends. This minimises the pressure loss in the refrigerant pipes and ensures that the compressor oil can flow back without obstruction.
- Make special preparations regarding the oil return if the outdoor unit is located above the indoor unit. (see section Oil return measures).
- Add refrigerant if the basic length of the refrigerant pipe exceeds 5 metres.

For the quantity of additional refrigerant, refer to chapter "Add refrigerant".

- Only use the union nuts for the refrigerant pipes included in the delivery, and remove them shortly before connecting the refrigerant pipes.
- Establish all electrical connections in accordance with the relevant DIN- and VDE standards.
- See electrical connection diagram. Ensure the electrical cables are properly connected to the terminals, otherwise there is a risk of fire.

CAUTION

Always pay attention to the affiliation of the electrical and refrigerant pipes! The connections of the individual circuits may not be mixed up. A mistake in this area can have fatal consequences!

NOTE

Different refrigerant pipes are required depending on the cooling output of the indoor unit.

Wall openings

- The wall breakthrough must have a diameter of min. diameter of min. 70 mm and a fall of 10 mm from inside to outside for each indoor unit.
- We recommend that the inside of the hole is padded or lined, e.g. using a PVC tube, to prevent the pipes being damaged. **(Page 11, figure 1).**
- After installation has been completed, use a suitable sealing compound to close off the wall breakthrough (responsibility of customer). Do not use materials containing cement or lime!

Installation material

The outdoor unit is fastened with 4 screws and a wall bracket to the wall or fixed by a floor bracket to the ground.

NOTE

Only use fixing materials which are suitable for the given application.

1 Pipes and cables in wall breakthrough

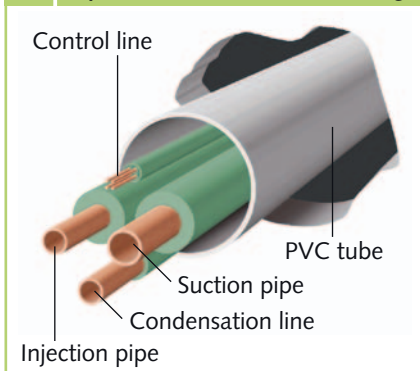

Selection of the installation location

The outdoor unit is designed for horizontal free-standing use in outdoor areas. It should be placed on level, flat and firm ground. The unit should also be secured to prevent toppling.

The outdoor unit can be installed both inside and outside buildings. In the case of outdoor installation, please follow the instructions given below to protect the unit against the weather.

2 Windbreak

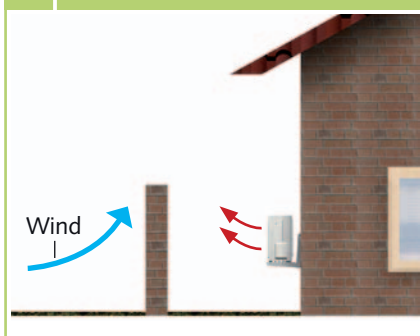

3 Minimum clearance to snow

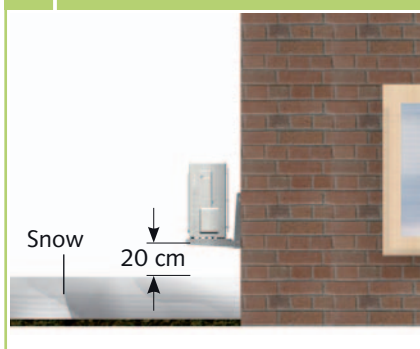

Rain

The unit should be at least 10 cm off the ground when mounted on the roof or ground. An optional floor bracket is available as an accessory.

Sun

The liquefier on the outdoor unit radiates heat.

Exposure to direct sunlight will further increase the temperature of the fins and reduce the heat output of the liquefier.

The outdoor unit should therefore be installed as near as possible to the north side of the building. If necessary, take measures to provide sufficient shade (responsibility of customer). One possible solution is to build a small roof. However, the discharging warm air flow may not be affected by the measures.

Wind

If the unit is being installed in windy areas, ensure the air discharges in the prevailing wind direction. If this is not the case it may be necessary to install a windbreak (provided by the customer) (Figure 2). Ensure that the windbreak does not adversely affect the air intake to the unit.

Snow

The unit should be wall-mounted in areas of heavy snowfall.

Installation should then be min. 20 cm above the expected level of snow to prevent snow from entering the outdoor unit (Figure 3). An optional wall bracket is available as an accessory.

Installation inside buildings

- Ensure there is adequate heat dissipation when placing the outdoor unit in cellars, attics, adjoining rooms or halls (Figure 4).
- Install an additional fan with a rated flow comparative to that of the outdoor unit being installed in the room. This is used in conjunction with ventilation ducts to compensate any pressure losses (Figure 4).
- Ensure a continuous and unobstructed air flow from outside, preferably using sufficiently large air inlets (Figure 4).
- Comply with any regulations and conditions affecting the statics of the building. If necessary, fit acoustic installation.

4 Installation inside buildings

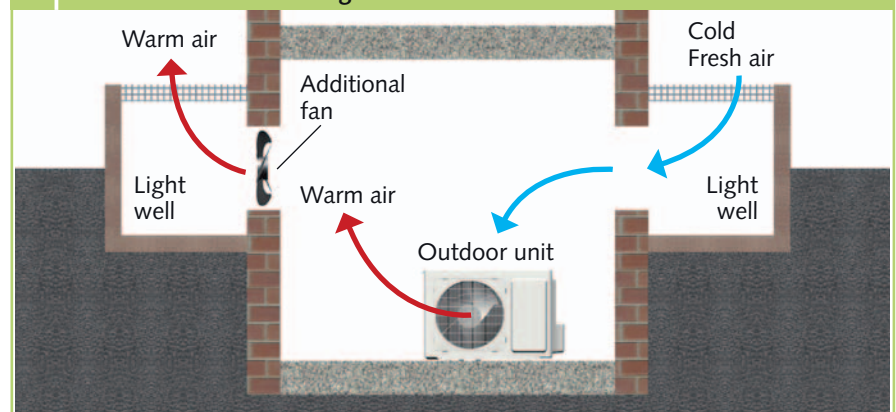

Minimum clearances

The following illustration indicates the minimum clearances for trouble-free operation of the equipment.

The protective zones serve to provide unhindered air intake and discharge, as well as providing sufficient room for performing maintenance and repairs and preventing the unit from being damaged.

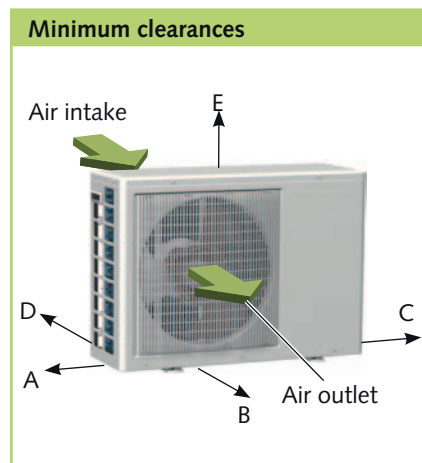

	MVT 600 DC	MVT 900 DC-1050 DC
A	100 mm	200 mm
B	1,200 mm	1,500 mm
C	600 mm	600 mm
D	150 mm	150 mm
E	600 mm	500 mm

Oil return measures

If the outdoor unit is installed at a higher level than the indoor unit, suitable oil return measures must be taken. Usually an oil pump bend is installed for every 2.5 metres of height difference.

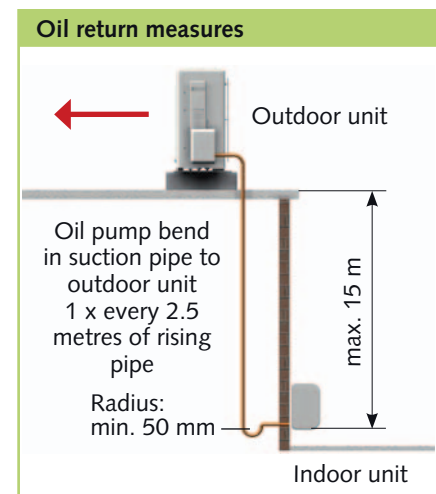

Installation

NOTE

Installation should only be performed by authorised specialists.

- The required pipe diameters are given in the table "Technical data" for the outdoor unit.
- Install the indoor unit can connect the refrigerant pipes as described in the manual for the indoor unit.
- Observe the permitted bending radius for the refrigerant pipes during installation. Never bend a pipe twice in the same place. Brittle pipes and potential cracking are the consequences.
- To bend the copper tubing, use the appropriate bending tool to prevent kinks in the tubing.
- Lay the refrigerant pipes from the indoor unit to the outdoor unit. In doing so, ensure adequate fastenings and and take measures for the oil return!
- Use the wall or floor brackets to fit the outdoor unit against structural parts approved to support the static load. Observe the installation instructions for the brackets.
- Ensure that structure-borne sound is not transferred to parts of the building. Use vibration dampers to reduce the effects of structure-borne sound!
- Remove the factory-fitted protective caps and union nuts on the stop valve connections. These should be used during installation.
- Before flanging the refrigerant pipes, ensure that the union nut is fitted on the pipe.
- Prepare the laid refrigerant pipes. **(Page 12, figures 5+6).**
- Verify that the shape of the flange is correct **(Page 12, figure 7).**

12. First connect and hand-tighten the refrigerant connections to ensure they are correctly seated.
13. Now fully tighten the fittings using 2 suitably sized open-ended spanners. Use one spanner to counter the force when tightening the fitting (**Figure 8**).
14. Fit appropriate heat insulation to both installed refrigerant pipes, including the connectors.
15. Only use insulation hoses which are designed for this temperature range and diffusion tight.

16. Proceed as described above for all of the subsequent refrigerant connections to the stop valves. Always observe the labelling and circuit affiliation of the injection and suction pipes!

NOTE

Use only tools which are approved for use in an HVAC environment. Bending pliers, pipe cutter, deburrer and flanging tool.

CAUTION

Check the connected injection and suction pipes for correct affiliation. Observe the letters on the labels! The connections of the individual circuits may not be mixed up.

Supplementary information for Installation

- When combining the outdoor unit with indoor unit MXW 350, the connection of the refrigerant pipes differs. In this case, install the expansion fittings to the outdoor unit provided in the outdoor unit's scope of delivery.
- If the basic length of the connection pipe exceeds 5 m, add refrigerant when commissioning the system for the first time. (See chapter „Add refrigerant“).

Tightness check

Once all the connections have been established, the pressure gauge station is attached as follows to the Schrader valve (if fitted):

- red = small valve = injection pressure
- blue = large valve = suction pressure.

Once connected, perform a tightness test using dried nitrogen. The tightness test involves spraying a leak detection spray onto the connections. If bubbles are visible, the connections have not been properly made. Re-tighten the connection or prepare a new flange. If the tightness test is successfully completed, depressurise the refrigerant pipes and start a vacuum pump with an absolute final partial pressure of min. 10 mbar to remove the air in the pipe. Any humidity present in the pipes is also removed.

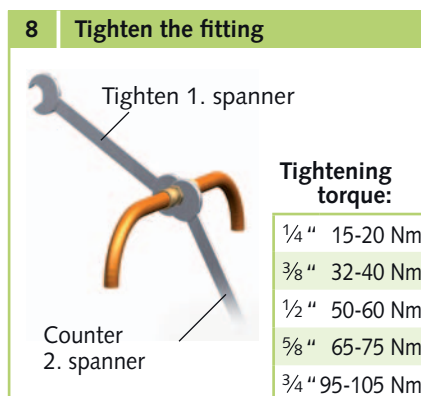
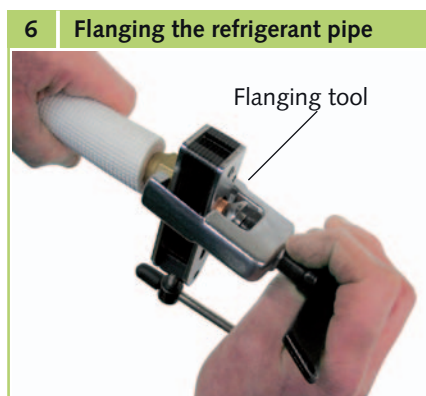
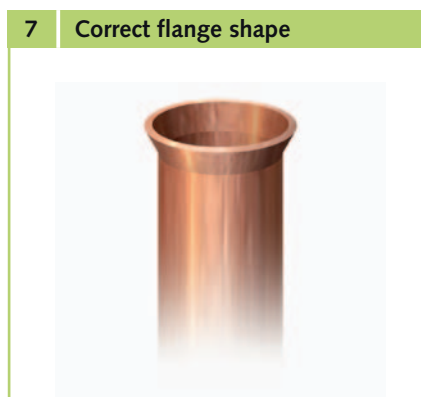
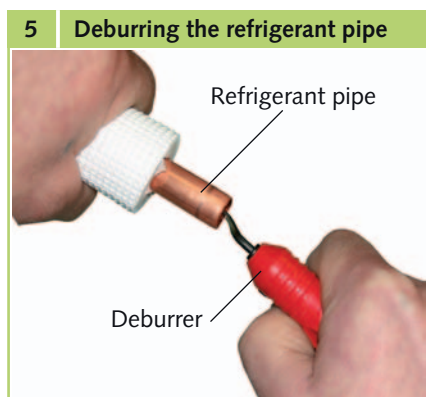

⚠ CAUTION

A vacuum of min. 20 mbar must be created!

The time required to generate the vacuum is dependent on the pipework volume of the indoor unit and the length of the refrigerant pipes. This always takes at least **60 minutes**.

Once any foreign gases and humidity have been completely extracted from the system, the valves on the pressure gauge station are closed and the valves on the outdoor unit are opened as described in the chapter on "Commissioning".

9 Connecting the outdoor unit

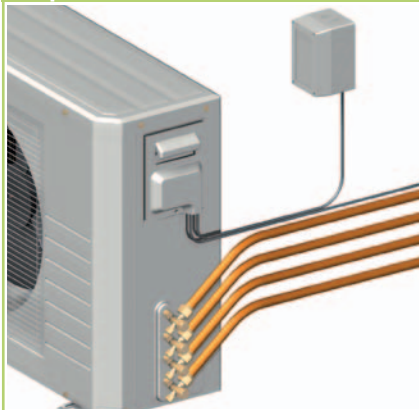

10 Connecting the cable

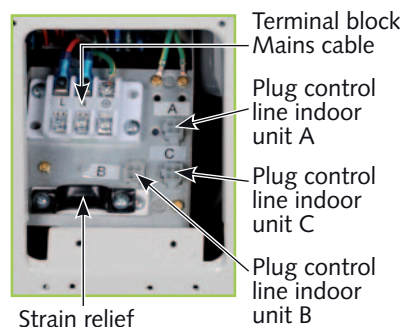

Electrical connection

For devices of series MVT 600-1050 DC, an electrical supply must be laid as mains supply to the outdoor unit as well as the supplied 4-core control line from the indoor unit to the outdoor unit.

We recommend that screened control lines are used with a minimum cross-section of 1.5 mm².

⚠ CAUTION

All electrical installation work should be performed by specialist contractors. Isolate the voltage supply when connecting the electrical terminals.

Connecting the outdoor unit

Before making the connection, observe the following information:

- Customers should install a terminal box in the vicinity of the outdoor unit. We recommend that a main/repair switch is used (**Figure 9**).
- Voltage is supplied to the indoor unit through the connection cable between the outdoor component and outdoor unit.

- Details concerning the electrical protection of the system are given in the technical data. Observe the required diameters!
- If the outdoor unit is installed on a roof, ensure it is protected against lightning strikes.
- Label the electrical control lines and the associated refrigerant pipes of each interior device with the same letter (A to D).

- Only connect the lines to their associated connections as labelled with the same letter. Mixing up the assignment of control lines and refrigeration pipes can lead to fatal consequences such as compressor damage!

Proceed as follows to connect the cable:

1. Remove the side panel next to the terminals.
2. Select the cable cross-section according to the relevant standards.
3. Feed the cables through the edge protection rings on the fixed connection panel.
4. Insert the control lines into the corresponding sockets. In doing so, pay attention to the alignment of the circuits.
5. If the supplied control lines are too short, they can be unclamped from the indoor unit and extended by an electrician.
6. Support the cable in the strain relief and re-assemble the unit.

💡 NOTE

Additional sensor and control lines may be required on some indoor units.

⚠ CAUTION

Check all plugged and clamped terminals to verify they are seated correctly and making a permanent contact. Re-tighten as required.

Electrical circuit diagram

MVT 600 DC

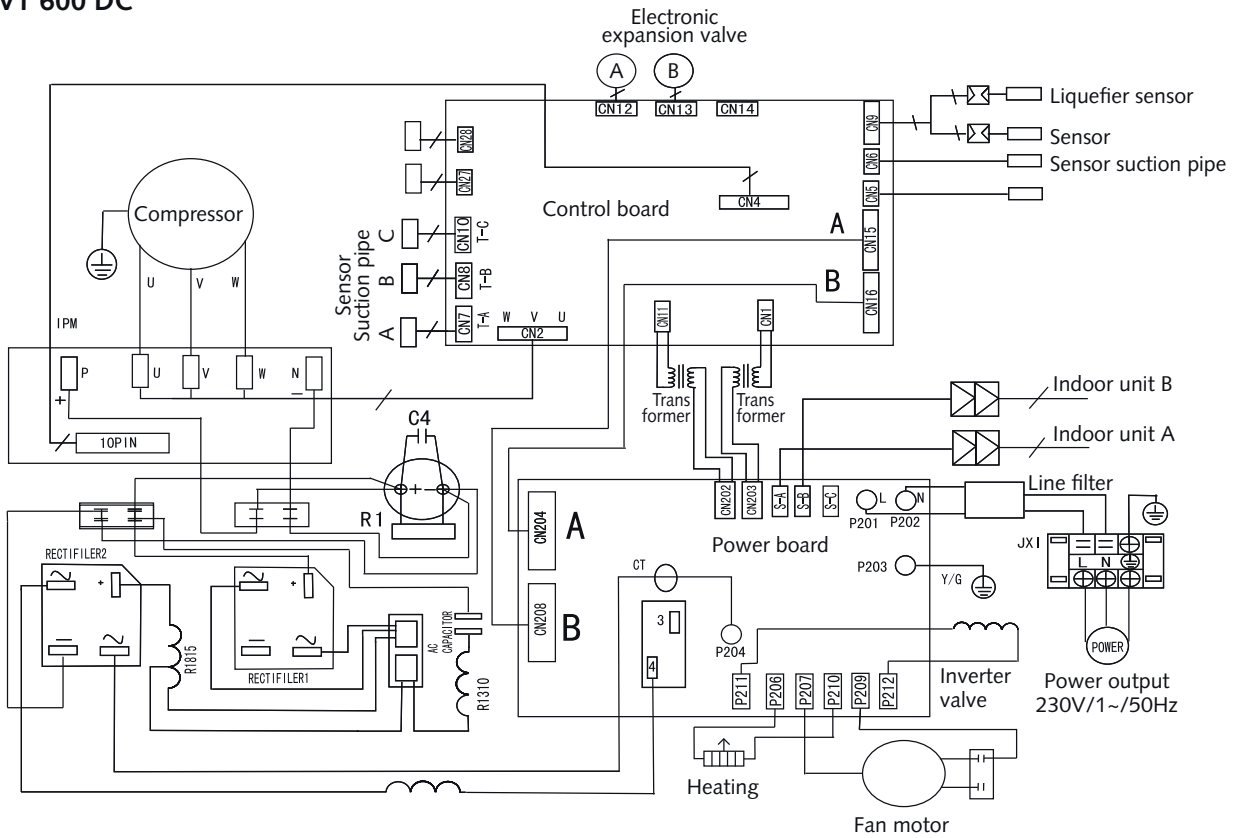

MVT 900 DC

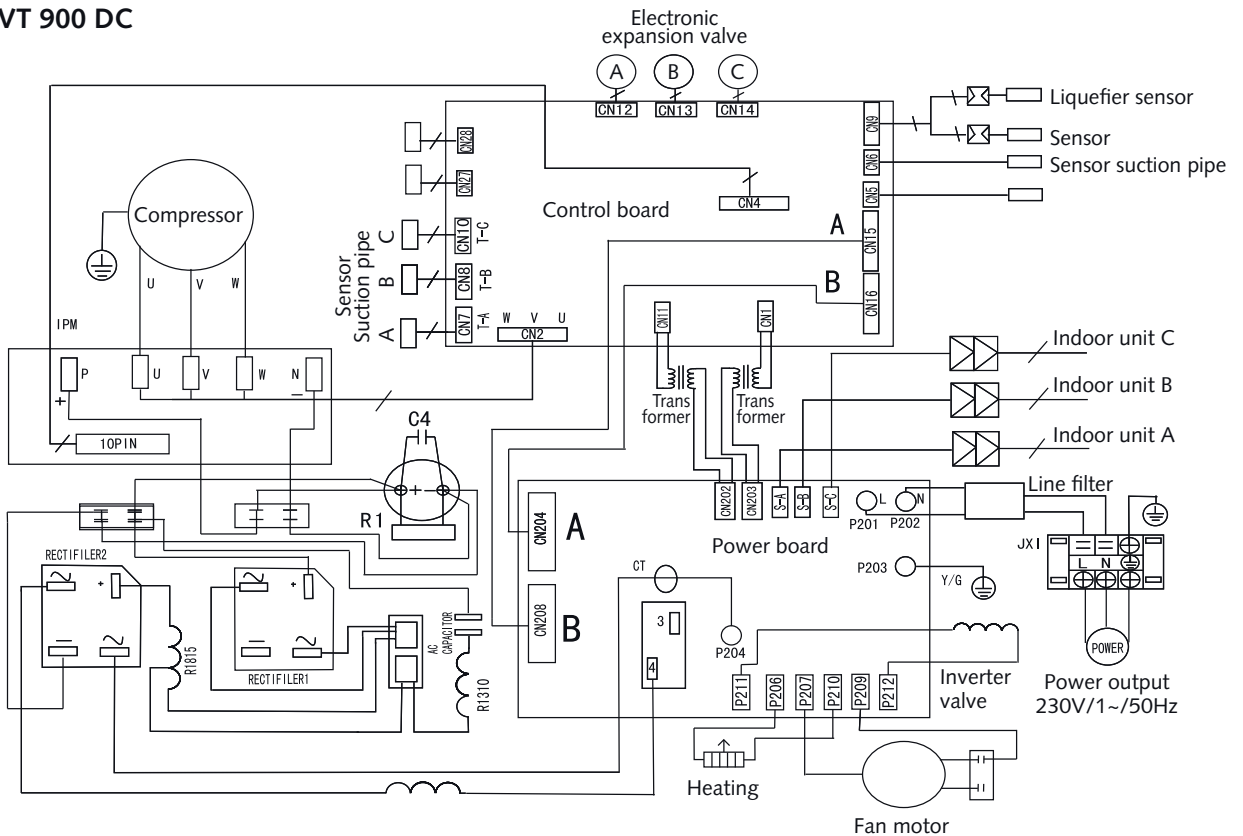

Electrical circuit diagram

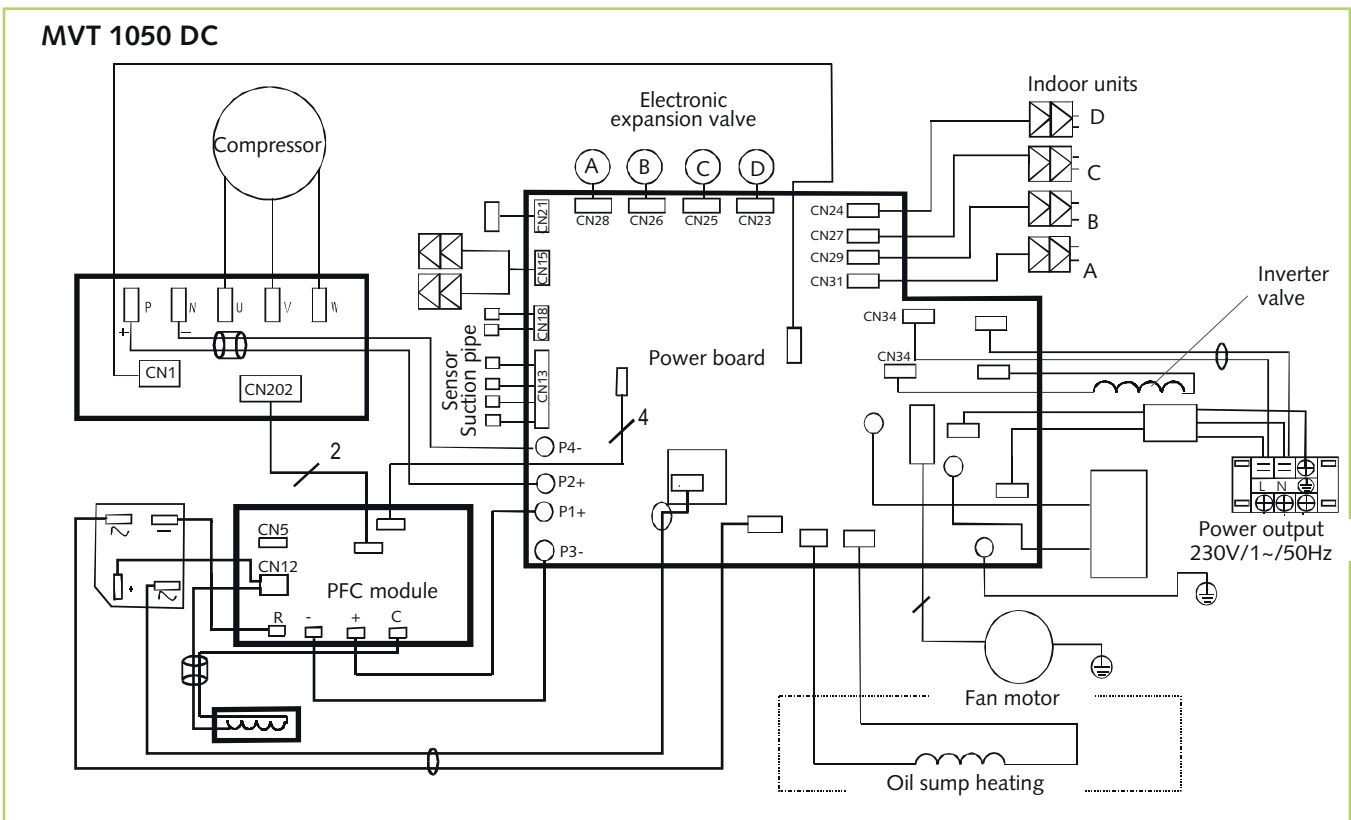
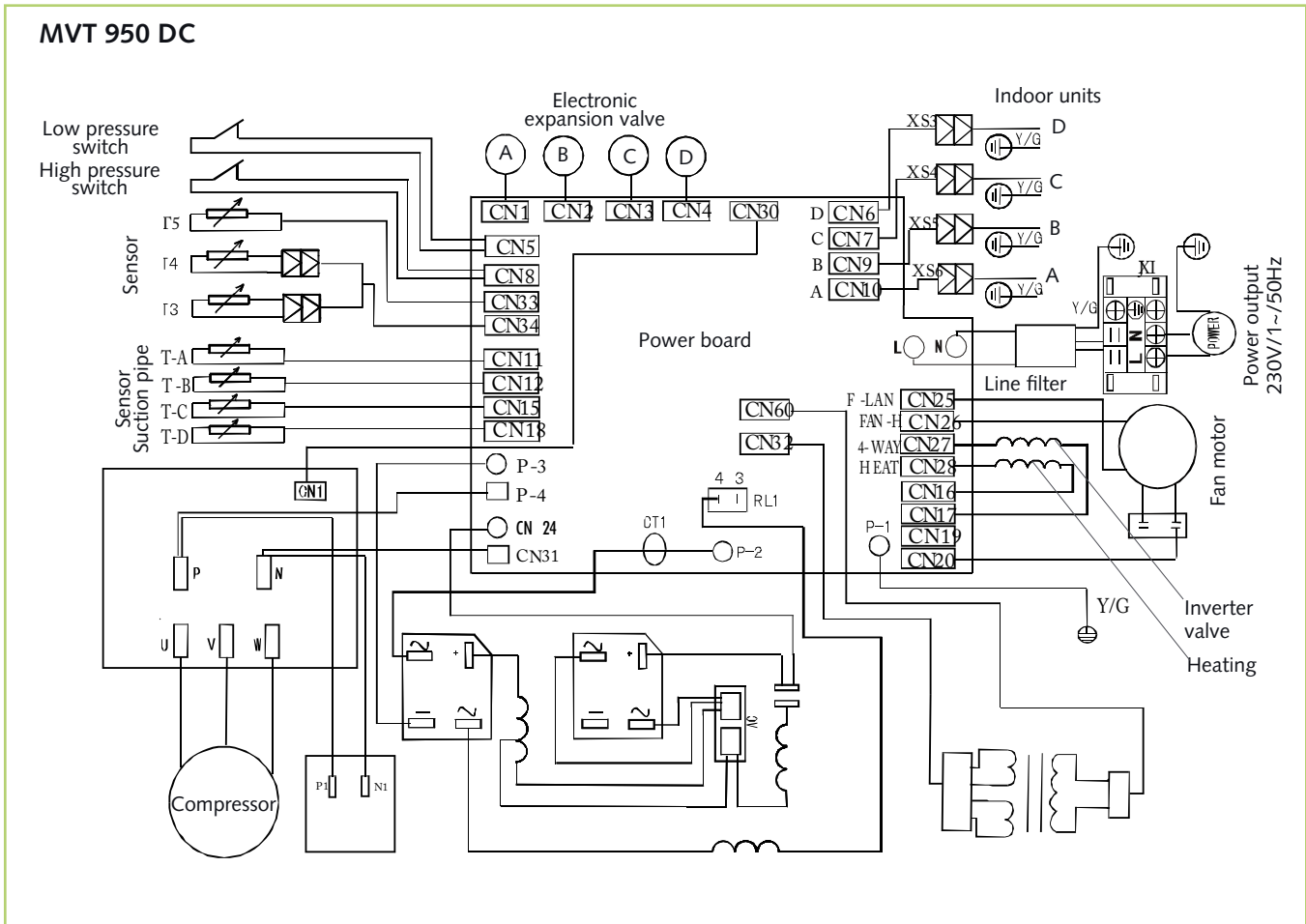

Electrical connection diagram

MVT 600 DC

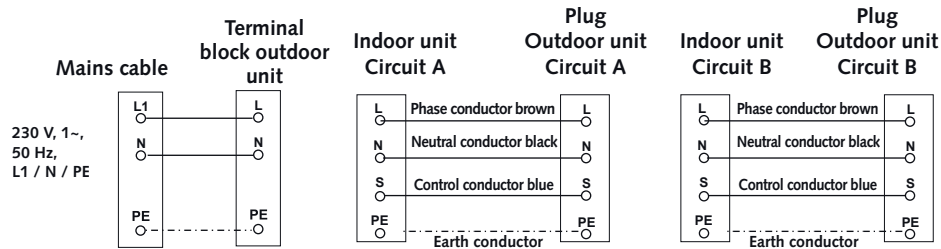

MVT 900 DC

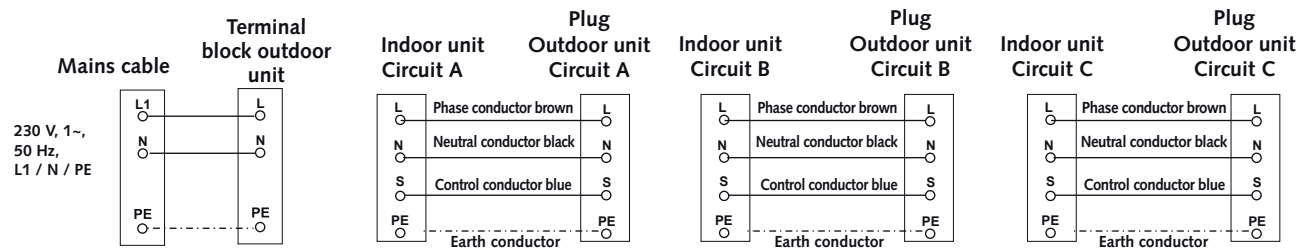

MVT 950 - 1050 DC

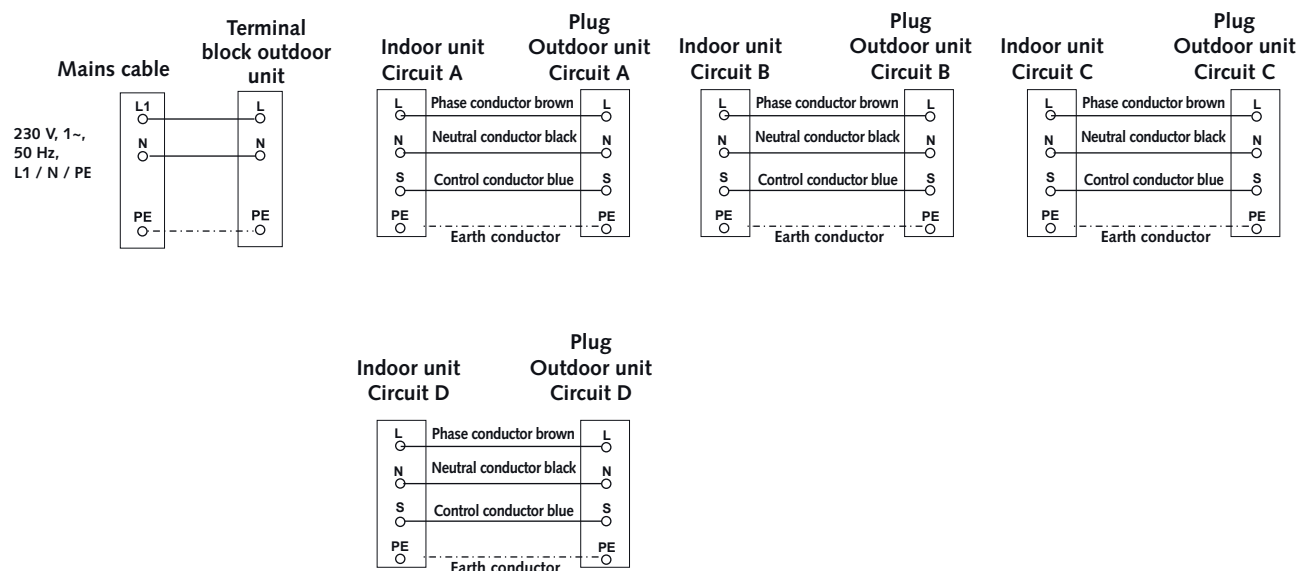

Before commissioning

After the tightness check has been successfully completed, connect the vacuum pump via the pressure gauge station to the valve connections on the outdoor unit (see chapter "Tightness check") and create a vacuum.

Perform the following checks prior to commissioning the unit for the first time and after any interventions affecting the refrigerant circuit. Record the results in the commissioning report:

- Check of all refrigerant pipes and valves with leak detection spray or soapy water for leaks and for inadvertent mix up of suction and injection pipe, with the unit at a standstill.
- Check of all refrigerant pipes and insulation for damage.
- Check of all electrical connections between indoor unit and outdoor unit for correct polarity.
- Check that all fastenings, mountings etc. are firm and at the correct level.

Add refrigerant

CAUTION

Note that the employed refrigerant is always filled in liquid form!

CAUTION

Wear protective clothing when handling refrigerant.

NOTE

Check the overheating to determine the refrigerant fill quantity.

The unit contains a basic quantity of refrigerant.

In addition, an additional amount of refrigerant must be added for refrigerant pipe lengths exceeding 5 meters per circuit. Refer to the following chart:

Basic pipe length	MVT 600 DC - 1050 DC	
	Additional filling quantity	
Up to and incl. 5 m	0 g/m	0 g/m
5 m to max. 15 m per circuit	30 g/m	30 g/m

Commissioning

NOTE

Commissioning should only be performed and documented by specially trained personnel.

Observe the manuals for the indoor unit and outdoor unit when commissioning the entire system.

The system can be commissioned once all the components have been connected and checked. A functional check should be performed to verify its correct function and identify any unusual operational behaviour prior to handing it over to the operator.

This check is dependent on the installed indoor unit. The procedures are specified in the manual for the indoor unit being commissioned.

CAUTION

Be sure to check the association of the electrical and refrigerant pipes before commissioning! The connections of the individual circuits may not be mixed up. Mixing up the assignment of control lines and refrigerant pipes can lead to fatal consequences (compressor damage)! Commissioning of the individual circuits must be carried out successively.

Function test and test run

Check the following points:

- Leak tightness of refrigerant pipes.
- Compressor and fan running smoothly.
- In cooling mode, cold air should be output by the indoor unit, and warm air should be output by the outdoor unit.
- Functional test of the indoor unit and all program sequences.
- Check of the surface temperature of the suction pipe and determination of vaporiser overheating.
To measure the temperature, hold the thermometer to the suction pipe and subtract the boiling point temperature reading on the pressure gauge from the measured temperature.
- Record the measured temperatures in the commissioning report.

Functional test for cooling mode.

1. Remove the protective caps from the valves.
2. Begin the commissioning process by briefly opening the stop valves on the outdoor unit until the pressure gauge indicates a pressure of approx. 2 bar.
3. Use leak detection spray or suitable devices to check that all the connections are tight. If no leaks are found, fully open the stop valves by turning them anti-clockwise using a spanner.

If leaks were found, draw off the refrigerant and rework the defective connection. It is imperative that the vacuum creation and drying steps are repeated!

4. Switch off the main circuit breaker or remove the fuse (provided by the customer).
5. Set the target temperature on the indoor unit using the remote control. This should be set to a value lower than the room temperature.
6. Switch the indoor unit to cooling mode.

NOTE

Due to the turn on delay, the compressor will start up a few minutes later.

7. Check the correct function and settings of all regulation, control and safety devices during the test run.

8. Check the control system in the indoor unit using the functions described in the manual. Timer, temperature settings and all mode settings.
9. Check the overheating, outdoor, indoor, outlet and vaporisation temperatures and record the measured values in the commissioning report.
10. Remove the pressure gauge.
11. Proceed as previously described for all other refrigerant circuits.

NOTE

Check the individual operating parameters with the help of the display on the outdoor unit as described on page 22 and note the value in the commissioning protocol.

Final tasks

- Use the remote control to set the target temperature to the required value.
- Re-fit all the dismantled parts.
- Familiarize the operator with the system.

NOTE

Check that the stop valves and valve caps are tight after carrying out any work on the refrigerant circuit. If necessary, use appropriate sealant products.

Function test and test run

During operation of the plant operating parameters can be called up on the outdoor unit display. The following parameters are displayed successively:

MVT 600 / 900 DC

- Frequency of the compressor
- Operating mode
- Current cooling / heating performance
- Number of indoor units
- Temperature sensor air inlet Liquefier
- Temperature sensor hot gas
- Power consumption outdoor unit
- Degree of opening for electronic expansion valve no. 1
- Degree of opening for electronic expansion valve no. 2
- Degree of opening for electronic expansion valve no. 3

MVT 950 / 1050 DC

- Frequency of the compressor
- Performance requirements IT
- Mode AT
- Current cooling / heating performance AT
- Operating mode fan AT
- Temperature sensor evaporator 4
- Temperature sensor evaporator 3
- Temperature sensor evaporator 2
- Temperature sensor evaporator 1
- Temperature sensor liquefier
- Temperature sensor air inlet Liquefier
- Temperature sensor hot gas
- Power consumption compressor
- Degree of opening for electronic Expansion valve no. 4
- Degree of opening for electronic expansion valve no. 3
- Degree of opening for electronic expansion valve no. 2
- Degree of opening for electronic expansion valve no. 1
- Current voltage
- Number of indoor units
- Previous error message

Proceed as follows to call up the operating parameters:

1. Remove the cover from the outdoor unit.

2. Switch all indoor units on and select cooling mode and the highest fan speed.

Display

The display on the outdoor unit PCB can call up the operating parameters of the plant in the above order. In order to do so, press the check button located next to the display on the AT board.

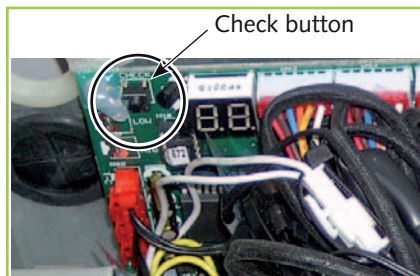

Frequency gauge

Display	Frequency (Hz)
30	30
--	Stand by
60	60

Operating mode

Display	Mode AT	Mode fan
0	Off	Off
1	Cooling mode	Low rotational speed
2	Heating mode	High rotational speed

Cooling - heating output AT / IT

Display	Cooling output
1	2.0-2.5 kW
2	2.5-3.0 kW
3	3.0-3.8 kW
4	3.8-5.0 kW
5	5.0-5.5 kW
6	5.5-6.1 kW
7	6.1-7.0 kW
8	7.0-7.5 kW
9	7.5-8.0 kW
10	8.0 kW
11	8.0-8.9 kW

Number of indoor units

Display	No. indoor unit
1	1
2	2
3	3
4	4

Temperature sensor air inlet

Display	Temperature
15	-7.5 °C
20	-5.0 °C
25	-2.5 °C
30	0 °C
35	2.5 °C
40	5.0 °C
45	7.5 °C
50	10.0 °C
55	12.5 °C
60	15.0 °C
65	17.5 °C
70	20.0 °C
75	22.5 °C
80	25.0 °C
85	27.5 °C
90	30.0 °C
95	32.5 °C
99	34.5 °C

Temperature sensor hot gas

Display	Temperature
10	35-40 °C
11	40-45 °C
12	45-50 °C
13	50-55 °C
14	55-60 °C
15	60-65 °C
16	65-70 °C

Power consumption outdoor unit

Display	Power consumption
44	6.0 A
46	6.2 A
54	7.4 A
55	7.6 A
58	7.8 A
62	8.0 A
66	8.6 A
67	8.8 A
68	9.0 A
70	9.2 A
72	9.5 A
76	10.0 A
78	10.2 A
80	10.4 A
82	10.6 A
84	11.0 A
88	11.6 A
92	12.0 A
94	12.2 A

Unit dimensions

MVT 600 DC / MVT 900 DC

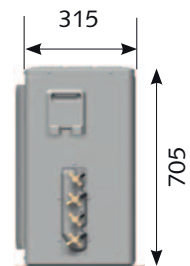
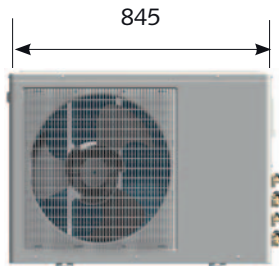
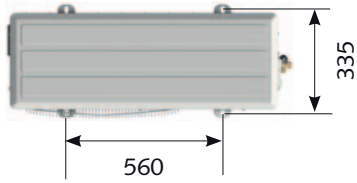

MVT 950 DC

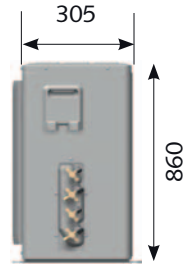
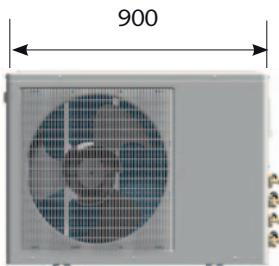
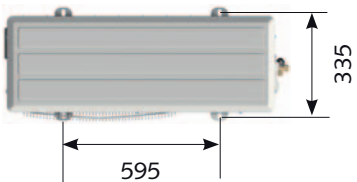

MVT 1050 DC

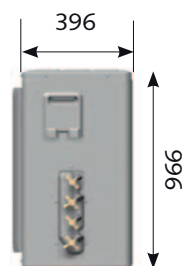
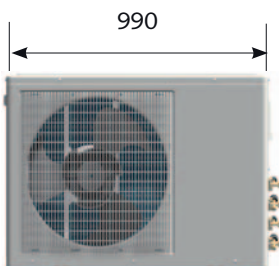
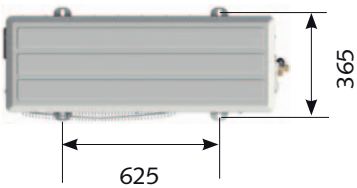

All values in mm

We reserve the right to modify the dimensions and constructional design as part of the ongoing technical development process.

Exploded view MVT 600 DC / MVT 900 DC/ MVT 950 DC / MVT 1050 DC

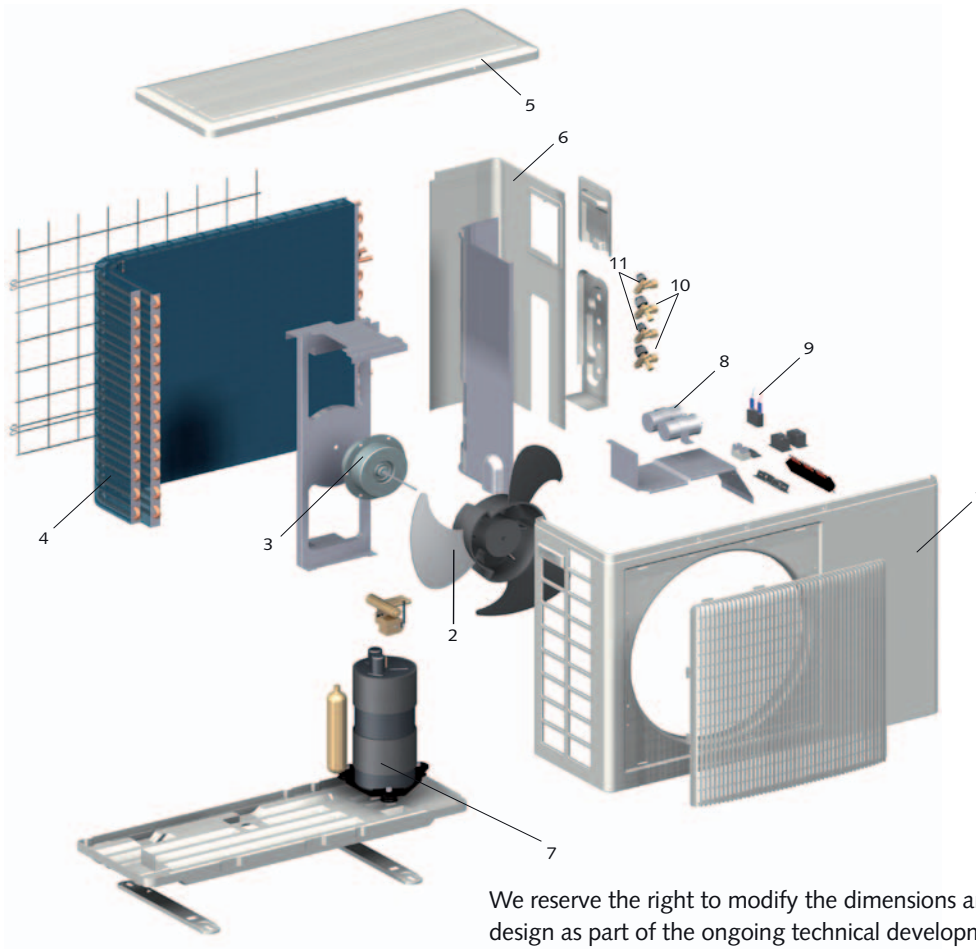

We reserve the right to modify the dimensions and constructional design as part of the ongoing technical development process.

Spare parts list

No.	Designation	MVT 600 DC	MVT 900 DC	MVT 950 DC	MVT 1050 DC
	from Series	783W6001	784W5000	785W6001	1042W5001
1	Front panel	111024	111024	111046	111074
2	Fan blade, liquefier	111100	111042	111047	111075
3	Fan motor, liquefier	111101	111026	111107	111076
4	Ribbed liquefier	111073	111027	111108	111077
5	Cover panel	111028	111028	111050	111078
6	Side panel, right	111029	111029	111051	111079
7	Compressor, complete	111102	111031	111052	111080
8	Condenser, compressor	111103	111033	111053	-
9	Condenser, liquefier fan	111104	111034	111109	111081
10	Stop valve, suction pipe	111035	111036	111055	111082
11	Stop valve, injection pipe	111037	111038	111056	111083
Spare parts (not illustrated)					
	Electronic expansion valve	111039	111039	111057	111084
	PCB with display	111105	111043	111110	111085
	Control PCB condenser	111106	111044	111111	111086
	Power board	-	111041	-	111087
	High pressure transducer	-	-	111061	111088
	Low pressure transducer	-	-	111062	111099

When ordering spare parts, please state the computerised part no., unit number and type (see identification plate) !

Technical data

		MVT 600 DC	MVT 900 DC	MVT 950 DC	MVT 1050 DC
Operating mode		Inverter multisplit outdoor units for cooling and heating			
Nominal cooling output ¹⁾	kW	5,22 (1,66-6,67)	7,80 (1,61-9,86)	7,91 (1,61-11,09)	10,56 (2,00-15,80)
Nominal heating output ²⁾	kW	6,10 (1,72-7,84)	8,75 (1,72-11,65)	8,79 (1,85-12,30)	11,10 (1,02-16,03)
Working range of outdoor unit, cooling	°C	-7 to +48			
Working range of outdoor unit, heating	°C	-7 to +34			
Refrigerant		R 410A ³⁾			
Energy efficiency class, cooling ¹⁾		A	A	A	B
Energy efficiency ratio EER ¹⁾		3,24	3,25	3,20	3,06
Energy efficiency class, heating ²⁾		A	A	A	C
Coefficient of performance COP ²⁾		3,65	3,62	3,41	3,28
(500h) K / H		805 / 835	1200 / 1210	1290 / 1410	1725 / 1690
Max. operating pressure	kPa	4200			
Air flow rate, max.	m ³ /h	2500		3000	5800
Noise output max.	dB(A)	49	58	60	61
Voltage supply	V/Hz	230V/1~/50Hz			
Protection degree	IP	24			
Nom. electrical power consumption, cooling ¹⁾	kW	1,61 (0,25-2,35)	2,40 (0,64-3,58)	2,58 (0,26-3,09)	3,45 (1,33-4,448)
Electr. nominal power consumption cooling ¹⁾	A	7,84 (4,60-8,50)	11,39 (5,11-11,50)	12,19 (3,93-13,05)	15,5 (5,81-16,89)
Nom. electrical power consumption, heating ²⁾	kW	1,67 (0,26-2,67)	2,42 (0,97-3,02)	2,82 (0,25-3,22)	3,38 (1,86-4,81)
Electr. nominal power consumption heating ²⁾	A	7,92 (5,32-8,78)	12,09 (5,32-12,13)	12,88 (4,17-13,95)	15,21 (7,23-16,98)
Electr. nominal power consumption compressor	A	9,70	9,80	10,80	13,50
Electr. starting current, max.	A	35	35	40	67
Electrical power consumption, max.		3,10	3,10	4,80	4,90
Compressor model		Rotary piston		Twin pistons	
Flow regulator		Electronic expansion valves			
Refrigerant, basic quantity	kg	2,15	2,25	2,55	2,70
Refrigerant, additional quantity > 5m	g/m	30	30	30	30
Refrigerant connection, injection pipe	Inches (mm)	1/4 (6.35)	1/4 (6.35)	1/4 (6.35)	1/4 (6.35)
Refrigerant connection suction pipe IU(2,00 kW)	Inches (mm)	3/8 (9.52)	3/8 (9.52)	3/8 (9.52)	3/8 (9.52)
Refrigerant connection suction pipe IU(2,60 kW)	Inches (mm)	3/8 (9.52)	3/8 (9.52)	3/8 (9.52)	3/8 (9.52)
Refrigerant connection suction pipe IU(3,5 kW)	Inches (mm)	1/2 (12.70)	1/2 (12.70)	1/2 (12.70)	1/2 (12.70)
Refrigerant connection suction pipe IU(5,2 kW)	Inches (mm)	1/2 (12.70)	1/2 (12.70)	1/2 (12.70)	1/2 (12.70)
Refrigerant pipe, max. length per indoor unit	m	20			
Refrigerant pipe, max. height per indoor unit	m	10			
Refrigerant pipe total, max.	m	30	45	60	70
Dimensions Height	mm	695	695	860	966
Width	mm	845	845	895	990
Depth	mm	335	335	335	396
Weight	kg	71	72	80	86
Serial number		783...	784...	785...	1042...
Computerised part no.		1623300	1623310	1623320	1623330

1) Outdoor temperature TK 35°C / FK 24°C, max. air flow rate, 5m pipe length in combination with 2/3/4 x MXW 260, 3x MXW 200

2) Outdoor temperature TK 7°C / FK 6°C, max. air flow rate, 5m pipe length in combination with 2/3/4 x MXW 260, 3x MXW 200

3) Contains greenhouse gas according to Kyoto protocol

IU = Indoor unit

Characteristic curves heat

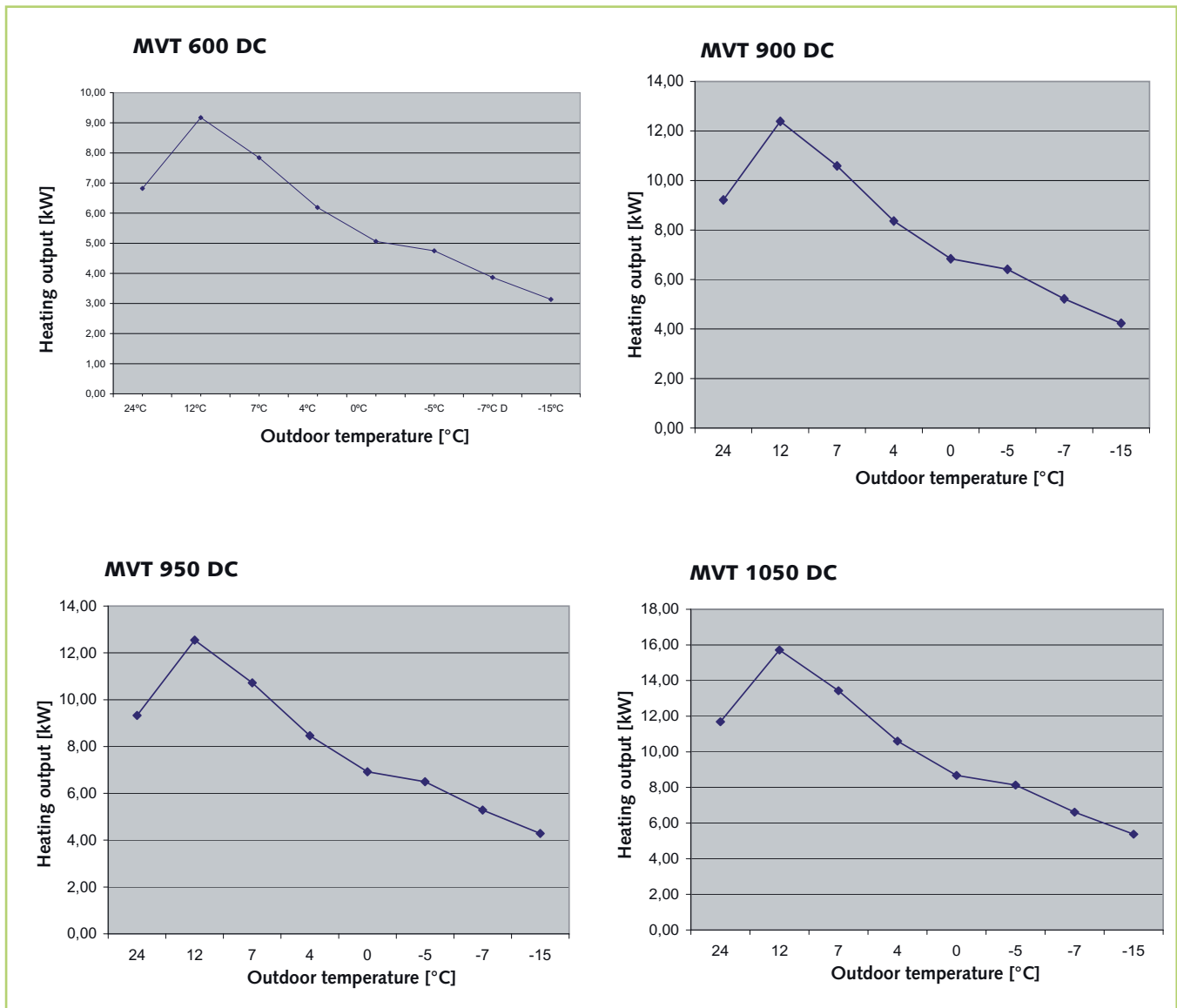

1) Air intake temp. TK 20°C outdoor temp. TK 7°C / FK 6°C, max. air volume, 5m pipe length

EC – Declaration of Conformity

(in accordance with the Machinery Directive, Appendix II A1)



- Original Declaration of Conformity

We do hereby declare that the devices named below, produced and sold by us, satisfy the relevant basic requirements of the EC guidelines, the EC safety standards and other product-specific EC standards.

Name of Manufacturer: **REMKO GmbH & Co. KG**
Air conditioning and heating technology
Im Seelenkamp 12
D - 32791 Lage

Equipment (machinery) - Implementation: **Inverter multisplit outdoor units**

Series / Designation: **REMKO MVT 600 DC, MVT 900 DC, MVT 950 DC, MVT 1050 DC**
Series / Class Number: 783...,784...,785...,1042...

Applicable regulations : (EC-Directive)	MA-RL 2006/42/EC	Machine directive
	NS-RL 2006/95/EC	Low-voltage directive
	EMV-RL 2004/108/EC	Electro-magnetic fields
	EnVkv-RL 92/75/EC	Energy consumption labelling directive
	EG 97/23/EC	Pressure Equipment Directive

Applicable Standards: (Harmonized EN)	EN 292-1; EN 292-2; EN 294
	EN 14511 T1-4
	DIN 4635-1
	EN 378-1-4
	EN 55014-1; EN 55014-2; EN 55104
	EN 60204-1; EN 60335-1; EN 60335-2-40
	EN 61000-3-2; EN 61000-3-3

Lage, 22. January 2010

REMKO GmbH & Co. KG

.....
Signature Product Manager

REMKO INTERNATIONAL

... and in your area!
Profit from our experience and advice



Consultancy

Intensive training means our consultants are always up-to-date with the latest developments. This has given us the reputation of being more than just a good and reliable supplier:

REMKO, a partner who helps solve problems.

Sales

REMKO not only has a well-established sales network at home and abroad, it also employs highly trained sales specialists.

REMKO Our field staff are more than just salesmen: above all, they must advise our clients in the areas of air conditioning and heating technology.

Customer Service

Our equipment is precise and reliable. However, should a fault should occur REMKO customer service is quickly at your side.

Our comprehensive network of experienced dealers guarantees quick and reliable service.

REMKO GmbH & Co. KG
Air conditioning and heating technology

Im Seelenkamp 12
Postfach 1827
Telephone
Telefax
E-mail
Website

D-32791 Lage
D-32777 Lage
+49 5232 606-0
+49 5232 606-260
info@remko.de
www.remko.de

Hotline

Air conditioning and heating technology
+49 5232 606-0

Export

+49 5232 606-130

