

REMKO MXW

MXW 200, MXW 260, MXW 350, MXW 520

Inverter wall - room air conditioner in multisplit design

Operation · Technology · Spare parts



Contents

<i>Safety notes</i>	4
<i>Environmental protection and recycling</i>	4
<i>Warranty</i>	4
<i>Intended use</i>	5
<i>Transport and packaging</i>	5
<i>Description of the equipment</i>	5
<i>Combinations</i>	6-7
<i>Operation</i>	8-15
<i>Shutdown</i>	15
<i>Care and maintenance</i>	15-16
<i>Troubleshooting and customer service</i>	17-18
<i>Installation instructions for qualified personnel</i>	19
<i>Installation</i>	20
<i>Condensation connection</i>	20
<i>Electrical connection</i>	21
<i>Electrical connection diagram</i>	22
<i>Electrical circuit diagram</i>	22
<i>Commissioning</i>	23
<i>Unit dimensions</i>	23
<i>Exploded view</i>	25
<i>Spare parts list</i>	25
<i>Technical data</i>	26
<i>EC-Declaration of Conformity</i>	27





These operating instructions should be read carefully prior to commissioning / operation of the equipment!

These instructions are part of the equipment and must always be kept in the vicinity of the installation or on the equipment
This operating manual is a translation of the German original, Version W-04

Subject to modifications; No liability accepted for errors or misprints!

Safety notes

Carefully read this manual before starting the unit for the first time. It contains useful tips, information  as well as hazard warnings to prevent injury or material damage . Non-observance of this manual may endanger persons, the environment as well as the equipment itself and will void any claims for liability.

- Store this manual as well as the refrigerant datasheet in the vicinity of the unit.
- The unit should only be set up and installed by qualified personnel.
- The setup, connection and operation of the unit and its components must be in accordance with the operating conditions stipulated in this manual and comply with all applicable local regulations.
- Units designed for mobile use should be safely set up on a suitable floor and in a vertical position. Units designed for stationary use should only be operated in their permanently installed state.
- It is prohibited to make modifications or changes to equipment or components supplied by REMKO as this may cause malfunctions.
- Equipment and components should not be operated in areas where there is a heightened damage risk. Observe the minimum clearances.
- The electrical supply should be adapted to fulfil the requirements of the unit.
- The operational safety of equipment and components is only assured providing they are used as intended and in a fully assembled state. Safety devices should not be modified or bypassed.
- Do not operate equipment or components with obvious defects or signs of damage.
- All housing parts and openings, e.g. air inlets and outlets, must not be blocked by foreign items, fluids or gases.
- The equipment and components must be kept in a safe distance from inflammable, explosive, combustible, aggressive and dirty areas or atmospheres.
- Persons coming into contact with equipment parts may suffer burns or injury.
- Installation, repair and maintenance work should only be carried out by authorised specialists. Inspection and cleaning can be performed by the operator providing the equipment is not under voltage.
- Take appropriate hazard prevention measures when performing installation, repair or maintenance work or cleaning the equipment.
- The equipment or components should not be exposed to any mechanical stresses, extreme levels of humidity or direct exposure to sunlight.



Environmental protection and recycling

Disposal of packaging

All products are packed for transport in environmentally friendly materials. Make a valuable contribution to reducing waste and sustaining raw materials. Only dispose of packaging at approved collection points.



Disposal of units and components

For the manufacture of the units and components, only recyclable materials have been used. Help protect the environment by ensuring that the units or components (for example batteries) are not disposed in household waste, but only in accordance with local regulations and in an environmentally safe manner, e.g. through authorised disposal and recycling specialists or at collection points.

Warranty

Prerequisite for any warranty claims is that the purchaser or his client has completely filled out the "warranty registration card" and commissioning report included with the unit at the time when the equipment was purchased and commissioned and returned the completed card to REMKO GmbH & Co. KG.

The warranty conditions are listed in the "General business and delivery conditions. The contractual parties can also agree additional terms beyond the scope of the above. For this reason please contact your direct contracting partner first.

Intended use

Depending on the model, the equipment and the additional fittings with which it is equipped is only intended to be used as an air-conditioner for the purpose of cooling or heating the air in an enclosed room.

Different or additional use shall not be classed as intended use. The manufacturer/supplier assumes no liability for damages arising from an unintended use of the equipment. The user bears the sole risk in such cases.

Using the equipment as intended also includes working in accordance with the operating manual and installation instructions and complying with the maintenance requirements.

Transport and packaging

The equipment is shipped in sturdy transport packaging. Immediately check the equipment on delivery and make a note of any damage or missing parts on the delivery note. Inform the forwarding agent and contractual partner.

Warranty claims at a later date will not be accepted.

Description of the equipment

The indoor unit on the split-design combined room air conditioning units serves to extract heat from the indoor room being cooled. The outdoor unit then expels this heat to the outside.

If combined heating/cooling units are operated as heaters, the heat absorbed by the outdoor unit can be discharged by the indoor unit into the room being heated.

The unit is designed for installation high up on indoor walls. It is operated via an infrared remote control.

The indoor unit consists of a fin vaporiser, vaporiser fan, regulation system and condensation pan. The indoor unit can be combined with REMKO outdoor units of series MVT 600/900/950/1050 DC with sufficient cooling output. The outdoor unit is controlled via the regulation of the indoor unit.

Condensation pumps are available as an accessory.

Schematic of refrigerant circuit

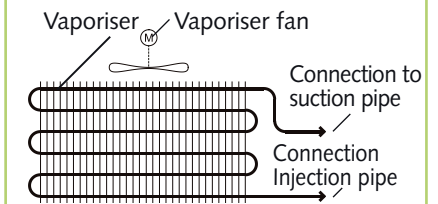

System layout

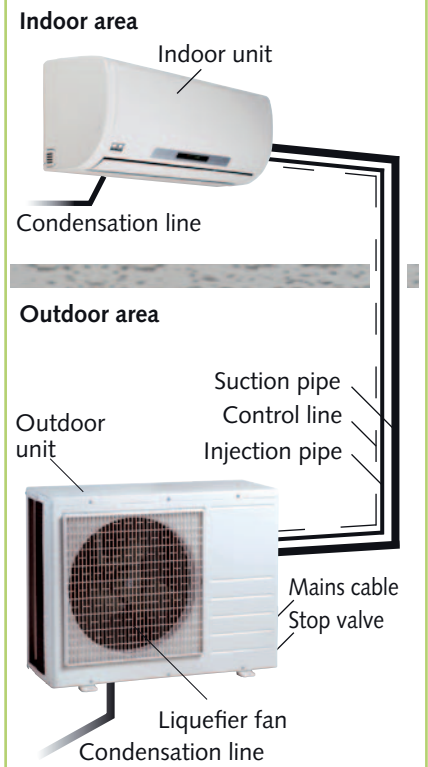

Refrigerant pipes are used to connect the indoor unit to the outdoor unit.

REMKO MXW

Combinations

Indoor units MXW 200-520 can be combined with MVT series outdoor units.
The following combinations are possible.

Outdoor unit MVT 600 DC

	MXW 200	MXW 260	MXW 350	MXW 520
One Indoor unit				
Combination 1	•			
Combination 2		•		
Combination 3			•	
Combination 4				•
Two Indoor units				
Combination 5	• •			
Combination 6		• •		
Combination 7	•	•		
Combination 8	•		•	
Combination 9		•	•	
Combination 10	•			•

Outdoor unit MVT 900 DC

	MXT 200	MXW 260	MXW 350	MXW 520
One indoor unit				
Combination 1	•			
Combination 2		•		
Combination 3			•	
Combination 4				•
Two indoor units				
Combination 5	• •			
Combination 6		• •		
Combination 7			• •	
Combination 8	•	•		
Combination 9	•		•	
Combination 10	•			•
Combination 11		•		•
Combination 12			•	•
Three indoor units				
Combination 13	• • •			
Combination 14		• • •		
Combination 15	• •	•		
Combination 16	• •		•	
Combination 17	•	• •		
Combination 18	•	•	•	
Combination 19	•		• •	
Combination 20		• •	•	
Combination 21		•	•	
Combination 22	• •			•

Outdoor unit MVT 950 DC

	MXW 200	MXW 260	MXW 350	MXW 520
One indoor unit				
Combination 1	•			
Combination 2		•		
Combination 3			•	
Combination 4				•
Two indoor units				
Combination 5	• •			
Combination 6		• •		
Combination 7			• •	
Combination 8	•	•		
Combination 9	•		•	
Combination 10		•	•	
Combination 11	•			•
Combination 12		•		•
Combination 13			•	•
Combination 14				• •
Three indoor units				
Combination 15	• • •			
Combination 16		• • •		
Combination 17			• • •	
Combination 18		• •	•	
Combination 19	• •	•		
Combination 20	• •		•	
Combination 21	•	• •		
Combination 22	•	•	•	
Combination 23	•		• •	
Combination 24		•	• •	
Combination 25	• •			•
Combination 26	•	•		•
Combination 27	•		•	•
Combination 28		• •		•
Combination 29		•	•	•
Four indoor units				
Combination 30	• • • •			
Combination 31		• • • •		
Combination 32	• • •	•		
Combination 33	• • •		•	
Combination 34	• •	• •		
Combination 35	• •	•	•	
Combination 36	•	• • •		
Combination 37	•	• •	•	
Combination 38		• • •	•	
Combination 39	• •		• •	
Combination 40	•	•	• •	
Combination 41	• • •		•	

Outdoor unit MVT 1050 DC

	MXW 200	MXW 260	MXW 350	MXW 520
One indoor unit				
Combination 1	•			
Combination 2		•		
Combination 3			•	
Combination 4				•
Two indoor units				
Combination 5	• •			
Combination 6		• •		
Combination 7			• •	
Combination 8	•	•		
Combination 9	•		•	
Combination 10		•	•	
Combination 11	•			•
Combination 12		•		•
Combination 13			•	•
Combination 14				• •
Combination 15	•			•
Combination 16		•		•
Combination 17			•	•
Combination 18				• •
Three indoor units				
Combination 19	• • •			
Combination 20		• • •		
Combination 21			• • •	
Combination 22		• •	•	
Combination 23	• •	•		
Combination 24	• •		•	
Combination 25	•	• •		
Combination 26	•	•	•	
Combination 27	•		• •	
Combination 28		•	• •	
Combination 29	• •			•
Combination 30	•	•		•
Combination 31	•		•	•
Combination 32		• •		•
Combination 33		•	•	•
Combination 34	•			• •
Combination 35		•		• •
Combination 36			• •	•
Four indoor units				
Combination 37	• • • •			
Combination 38		• • • •		
Combination 39	• • •	•		
Combination 40	• • •		•	
Combination 41	• •	• •		
Combination 42	• •	•	•	
Combination 43	•	• • •		
Combination 44	•	• •	•	
Combination 45		• • •	•	
Combination 46	• •		• •	
Combination 47	•	•	• •	
Combination 48	• •	•		•
Combination 49	• •		•	•
Combination 50	• •			• •
Combination 51	•	• •		•
Combination 52	•	•	•	•
Combination 53	• • •			•
Combination 54		• • •		•
Combination 55	•		• •	•

REMKO MXW

Operation

The indoor unit is easy to operate using an infrared remote control. This is supplied as standard. The indoor unit beeps to acknowledge the correct transmission of data. If it is not possible to program the indoor unit with the remote control, then it can also be manually operated.

Manual operation

The indoor units can be put into operation manually. After the air inlet screen has been opened, the inner recessed button can be pressed and automatic mode can

be activated. In manual operation, the following settings apply:

Cooling mode: last setting
Fan speed AUTO
Heating mode: last setting
Fan: AUTO

Press the button on the infra-red remote control to interrupt manual operation.

Infrared remote control

The infrared remote control sends the programmed settings in a distance of up to 6 m to the

receiver of the indoor unit. A trouble free reception of data is only possible if the remoter control is directed to the receiver and no objects hinder the transmission.

First insert the supplied batteries (two each, Type AAA) into the remote control. To do so, remove the cover on the battery compartment and insert the batteries, in correct polarity. (see marks).

Display on indoor unit

The display lights up according to the settings.

⚠ CAUTION

Problems are shown in code (see chapter Troubleshooting and Customer service).

💡 NOTE

Immediately replace flat batteries with a new set, otherwise there is a risk of leakage. It is recommended that the batteries are removed if the equipment is shut down for long periods.

Display on indoor unit

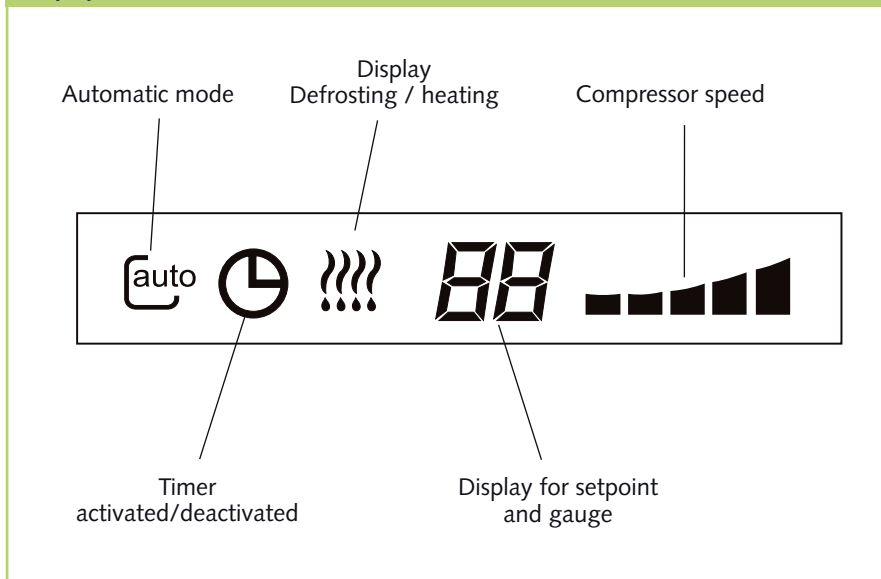

Maximum distance



Buttons on the remote control

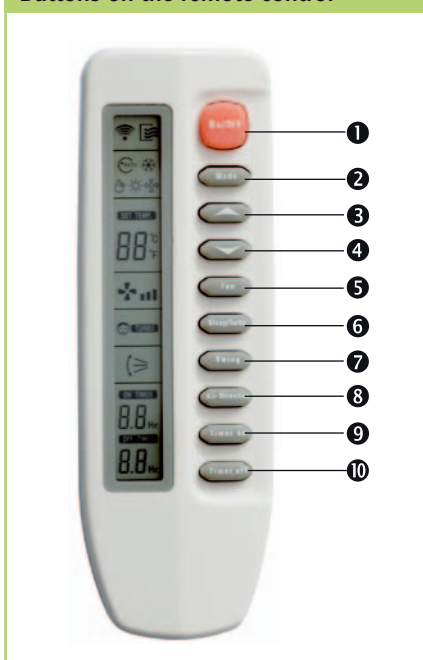

Buttons on the remote control

❶ "ON/OFF" Button

Press this button to start the unit.

❷ "MODE" Button

Press this button to select the operating mode. The indoor unit has 5 modes:

1. Automatic mode

In this mode, the unit works in cooling or in heating mode.

2. Cooling mode

In this mode, the warm room air is cooled to the desired temperature.

3. Dehumidification mode

In this mode the room is mainly dehumidified, the adjusted temperature is retained.

4. Heating mode

In this mode, the warm air in the room is warmed up to the desired temperature.

5. Circulation mode

In this mode, the air in the room is recirculated. Temperature selection is not possible.

❸ Button "▲"

This button is used to the desired temperature can be increased up to 30 °C.

❹ Button "▼"

This button is used to the desired temperature can be increased down to 17 °C.

❺ "FAN" button

Press this button to set the required fan speed. 4 settings are available: automatic, high, medium and low fan speed.

❻ "SLEEP/TURBO" Button

Pressing this button will automatically increase or decrease the target temperature by 1 °C within an hour in cooling and heating mode respectively.

With the TURBO function, the maximum fan speed can be activated.

❼ "SWING" Button

This button directly activates the oscillating function of the fins for better air distribution in the room.

❽ "AIR DIRECTION" Button

With this button, the desired fin position can be set. There are 5 positions and an oscillating function available.

❾ "TIMER-ON" Button

This button serves to program the automatic activation time for the device within the next 24 hours.

❿ "TIMER-OFF" Button

This button serves to program the automatic switch-off time for the device within the next 24 hours.

REMKO MXW

Button functions

A symbol is shown on the display to indicate that the settings are being transferred.

ON/OFF Button



By pressing the ON / OFF button, you can activate or deactivate your unit. The programmed settings and adjustment values before the unit was turned off will appear on the display.

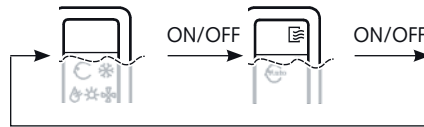

▲▼ Buttons

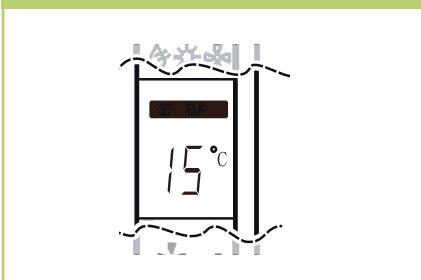

The ▲/▼ buttons can be used to reduce and increase the desired nominal temperature.



MODE Button



Use the MODE button to select between the individual operating modes. A total of 5 modes are available:

1. **Automatic** automatic selection of cooling or heating operation
2. **Cooling** predominantly summer operating mode
3. **Dehumidification** Summer or winter operating mode
4. **Heating** predominantly winter operating mode
5. **Air circulation** only for circulation of air

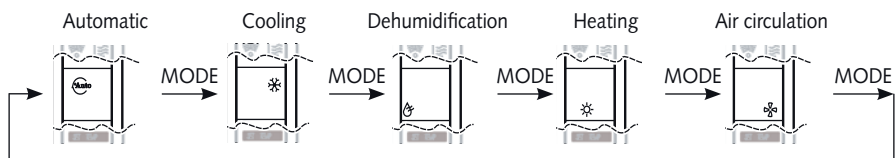

AUTOMATIC Mode



In automatic mode, the control system autonomously selects between heating, cooling and circulating modes. The nominal temperature can only be preselected in a different mode and is then applied to automatic mode.

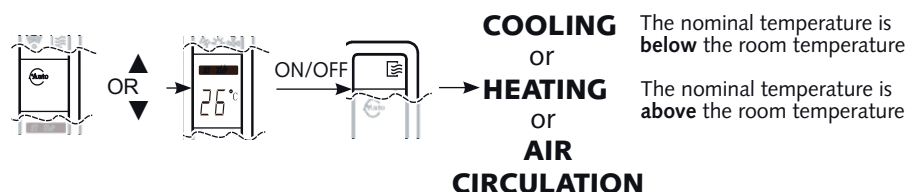

COOLING Mode



In cooling mode, the air in the room is cooled down to the set target temperature. The desired room temperature is set with the ▲/▼ buttons in 1 °C increments. If the room temperature is 1 °C above the selected nominal temperature, the indoor unit starts to cool the air in the room. The inverter controller checks the difference between the adjusted target temperature and the actual room temperature. If there is a large difference, the cooling output is very high. If the difference is smaller, a lower cooling output is produced. This serves to maintain the air discharge temperature and the room temperature. If the adjusted room temperature is lower than approx. 2 °C, then the control system turns the cooling function off. To protect the compressor, the regulation only turns the cooling on again after a waiting period of 3 minutes.

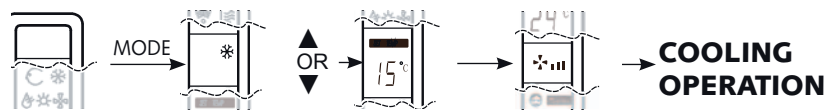

Functional diagram

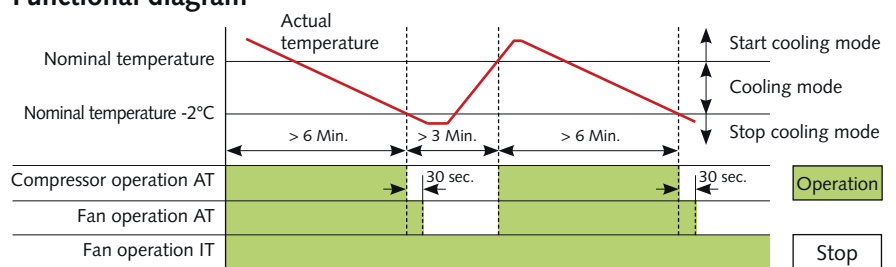

DEHUMIDIFICATION Mode



In dehumidification mode, the room temperature is set to 24 °C. Due to the low temperature of the refrigerant, the dew point of the air on the vaporiser is lower. The excess moisture in the air is condensed by the vaporiser, the room is dehumidified. The fan speed should be set to automatic in order to achieve a maximum level of dehumidification. In automatic mode, the fan is intermittently switched on and off.

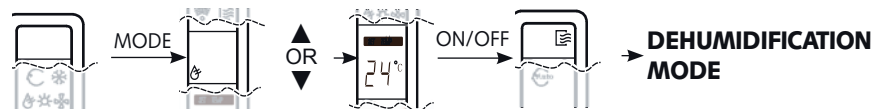

Functional diagram

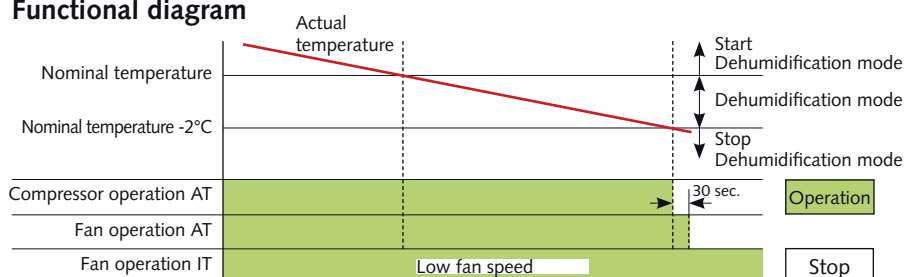

HEATING Mode



In the heating mode, you can simultaneously heat all of the rooms in spring or fall. The desired room temperature is set with the ▲/▼ buttons in 1 °C increments. If the room temperature is 1 °C below the selected target temperature, the indoor unit starts to heat the air in the room. The inverter controller checks the difference between the adjusted target temperature and the actual room temperature.

In the event of a greater difference, a higher cooling performance is created.

In the event of a smaller difference, a lower cooling performance is created.

This serves to maintain the air discharge temperature and the room temperature.

If the set room temperature is exceeded by approx. 2 °C, then the control system turns the heating function off. To protect the compressor, the regulation only turns the heater on again after a waiting period of 3 minutes.

In heating mode, the indoor unit fan motor is switched on after a delay, in order to prevent the discharge of cold air.

The fins on the outdoor unit could crack at low outdoor temperatures. Regular reversal of the cooling circuit results in a defrosting action. The display shows "H1" during the defrosting period.

CAUTION

Heating mode has priority!

If an indoor unit switches over to heating mode, then cooling is switched off for the other indoor devices in cooling mode.

Cooling is not possible during heating operation.

Heating mode operational sequence



Functional diagram

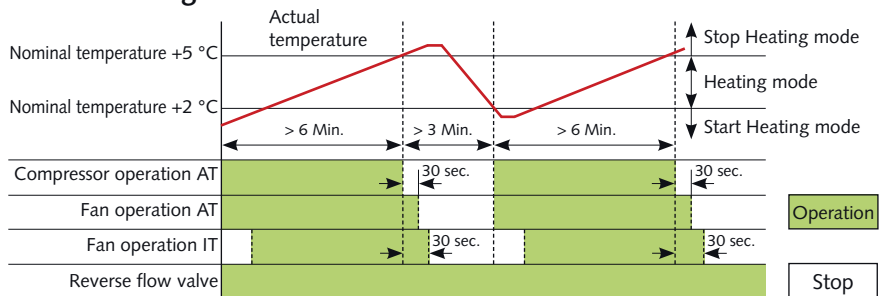

During the defrosting cycle, the indoor unit vaporiser fan and the outdoor unit liquefier fan are switched off.

After the cycle is concluded, the fans are switched to their previous settings.

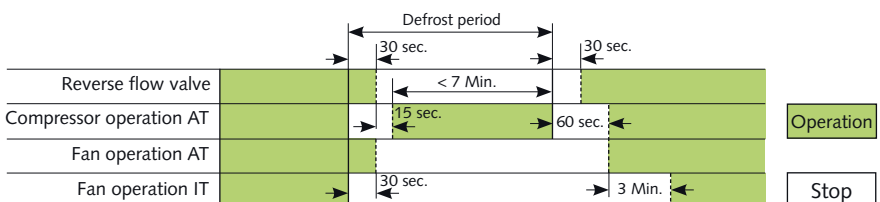

AIR CIRCULATION Mode



In ventilation mode, the air in the room is only circulated. The room temperature cannot be changed in this mode. The cooling or heating operation is not activated.

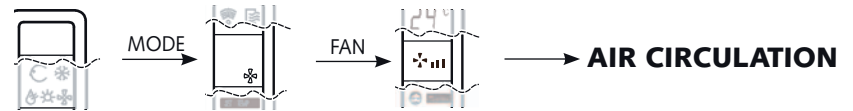

FAN Button



The fan speed can be adjusted with this button. A selection can be made between low, medium, high and automatic fan speed.

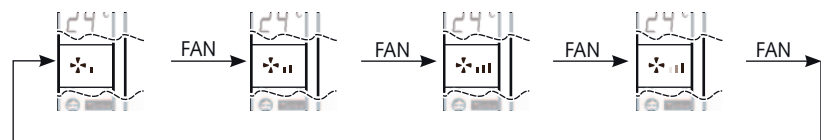

SLEEP/TURBO Button



This button activates a programming function, which causes the target temperature in cooling mode to increase after one hour by 1°C and after two hours by 2 °C. In heating mode, the target temperature is decreased after one hour by 1 °C and after 2 hours by 2 °C. The display on the indoor unit goes out. The TURBO function is used to activate the maximum fan speed

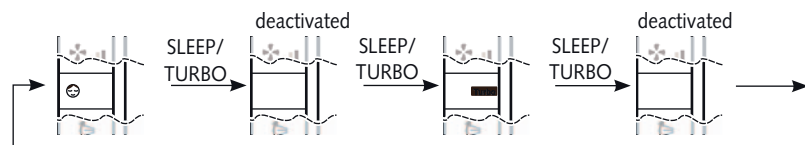

SWING and AIR DIRECTION Buttons

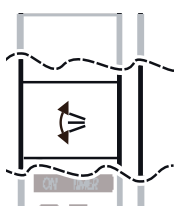

The oscillating function of the air discharge fins can be adjusted with this button. The air distribution in the room is improved with the swing function. In order to adjust the aim of the air discharge fins to a particular direction, the AIR DIRECTION button must be pressed briefly. In order to activate the automatic swing function, the AIR DIRECTION button must be pressed for longer than 2 seconds.

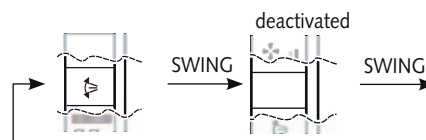

REMKO MXW

TIMER Button • TIMER-ON / OFF

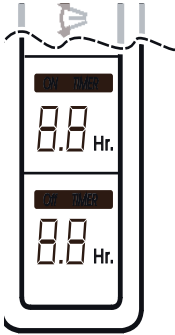

The activation and switch-off time can be programmed with this button. The timer is activated/deactivated by means of pressing the timer on and the timer off button. The timer symbol ON TIMER or OFF TIMER appears. The desired activation or switch-off time for the display up to 9.5 (hours) in 30 minute intervals and from displayed 10 in 60-minute intervals can be adjusted by means of pressing the Timer on or the Timer off buttons.

When the programmed time has been reached, the device is automatically turned on or off. If the indoor unit is automatically switched on, then the mode, temperature and fan speed for the last setting is reactivated.

The prior deletion of the on and off time can be achieved by pressing the On/Off button. The timer display on the indoor unit goes out.

TIMER ON button - activation delay



TIMER OFF button - switch-off delay



Manual air distribution

There are individually adjustable fins for adjusting the horizontal air distribution on the air discharge side.

⚠ CAUTION

Moving interior parts, e.g. fans, have the potential to cause injury during operation! Only make adjustments after swing operation has been switched off.

Manual air distribution

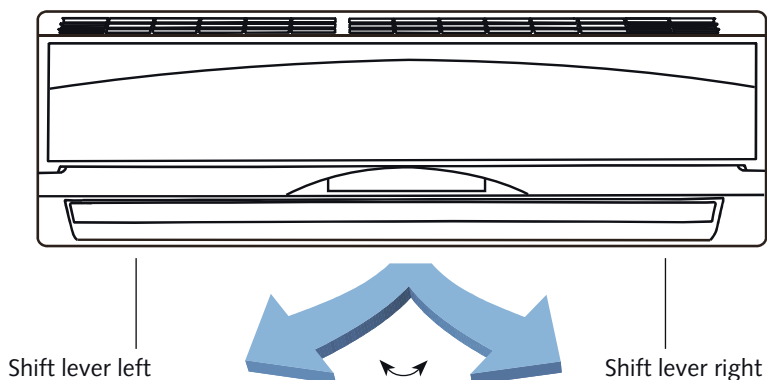

Shutdown

Temporary Shutdown

1. Allow the indoor unit to run for 2 to 3 hours in air circulation mode or in cooling mode at the maximum temperature setting in order to remove any residual moisture from the unit.
2. Shut down the system using the remote control.
3. Switch off the voltage supply to the unit.
4. Check the unit for visible signs of damage and clean it as described in the chapter "Care and maintenance".

Permanent Shutdown

Ensure that equipment and components are disposed of accordance with local regulations, e.g. through authorised disposal and recycling specialists or at collection points.

Contact REMKO GmbH & Co. KG or your contract partner for a list of specialist companies near you.

Care and maintenance

Regular care and observation of some basic points will ensure trouble-free operation and a long service life.

⚠ CAUTION

Prior to performing any work, ensure the equipment is isolated from the voltage supply and secured to prevent accidental switch-on!

Care

- Ensure the unit is protected against dirt, mould and other deposits.
- Clean the indoor and outdoor unit using a damp cloth. Do not use any caustic, abrasive or solvent-based cleaning products. Do not use a jet of water.
- Clean the fins on the unit prior to long shutdown periods.

Maintenance

- It is recommended that maintenance contract with annual maintenance interval with an appropriate specialist company.

💡 TIP

This ensures the operational reliability of your equipment!

💡 NOTE

The statutory regulations require an annual sealing test for the refrigerant circuit in relation to the refrigerant filling level. The inspection and documentation is to be carried out by corresponding specialist engineers.

Type of task Checks/ Maintenance/ Inspections	Commissioning	Monthly	Six-monthly	Yearly
General	●			●
Measure voltage and current	●			●
Check compressor/fans are functioning correctly	●			●
Check fan is functioning correctly	●			●
Dirt on liquefier/vaporiser	●	●		
Check refrigerant fill quantity	●		●	
Check condensation drain	●		●	
Test insulation	●			●
Check moving parts	●			●
Sealing test for refrigerant circuit	●			● ¹⁾

1) see note

Cleaning the housing

1. Disconnect the power supply to the unit.
2. Open the air intake grill on the front side and fold it upward.
3. Clean the grill and housing using a soft, damp cloth.
4. Reconnect the power supply again.

Air filter for indoor unit

Clean the air filter at intervals of no more than 2 weeks. Reduce this interval in case of heavily soiled air.

Cleaning the filter

1. Disconnect the supply voltage to the equipment.
2. Open the front side of the unit by folding the grill upward and letting it engage (**Fig. 1**).
3. Lift the filter up slightly and pull it out from underneath (**Fig. 1**).
4. Clean the filter with a regular vacuum cleaner (**Fig. 2**).
To do so, turn the dirty side upward.
5. Any dirt can also be removed carefully with lukewarm water and mild cleaning agents (**Fig. 3**).
To do so, turn the dirty side downward.
6. If water is used, let the filter dry out properly in air before replacing it in the unit.
7. Carefully insert the filter. Ensure it locates correctly.

8. Close the front side as described above but in reverse order.
9. Switch the supply voltage back on.
10. Switch the unit back on.

Cleaning the condensation pump (optional equipment)

An optional integrated or separate condensation pump may be in the indoor unit, which pumps out any accumulated condensation into higher positioned drains.

Observe the care and maintenance guidelines in the separate operating instruction manual.

1 Fold up the guard



2 Clean with a vacuum cleaner



3 Cleaning with lukewarm water



Troubleshooting and customer service

The equipment and components are manufactured using state-of-the-art production methods and tested several times to verify their correct function. If malfunctions should occur, please check the functions as detailed in the list below. For installations with an indoor unit and outdoor unit, refer to the chapter "Troubleshooting and customer service" in both manuals. Please inform your dealer if the unit is still not working correctly after all the functional checks have been performed!

Malfunction

Fault	Possible cause	Check	Remedial measures
The unit does not start or switches itself off.	Another indoor unit is in heating mode.	Check the mode of the other indoor units.	Operate all indoor units in cooling mode or switch them off.
	Power outage, undervoltage	Are all other electrical installations functioning correctly?	Check voltage if necessary wait before switching back on
	Defective mains fuse Main circuit breaker is open	Are all lighting circuits functioning correctly?	Replace mains fuse Close main circuit breaker
	Damaged mains cable	Are all other electrical installations functioning correctly?	Repair by a specialist
	Waiting time after switch-on too short	Is there a restart after approx. 5 minutes?	Schedule longer waiting periods
	Temperature outside operating range	Are the fans for the indoor unit and outdoor unit working?	Note the temperature ranges of the indoor unit and the outdoor unit
	Overvoltages due to thunderstorms	Have there been any lightning strikes in the area recently?	Turn the main fuse off and turn it on again Have it checked by a specialist
Fault in external condensation pump	Did the pump turn off due to a fault outage?	Check pump clean if necessary	
The unit does not respond to the remote control	Transmission distance too large / Receiver faulty	When pressing the button is there a signal sound on the indoor unit?	Reduce the distance to less than 6 m or change position
	Defective remote control	Is the outdoor component in manual operation?	Replace the remote control
	Receiver or transmitter unit exposed to excessive solar radiation	Is the function working if shaded?	Place the transmitter or receiver unit in the shade
	Electro-magnetic fields interfere with transmission	Is the function working when turning off any sources of interference?	Signal is not transmitted when interference sources are operational
	Button on remote control jammed / two buttons pressed at same time	Does the "Send" symbol appear on the display?	Release the button / only press one button
	Batteries in remote control depleted	Have new batteries been inserted? Is the display incomplete?	Insert new batteries

Please note the continuation of this „Troubleshooting chart“ on the next page !

Fault	Possible cause	Check	Remedial measures
The unit is running with reduced or without cooling or heating output	Filter is dirty / air inlet / outlet opening is blocked by debris	Have the filters been cleaned?	Clean the filters
	Doors and windows open / heating or cooling load was increased	Have there been any constructional / application-related changes?	Close doors and windows / install additional systems
	Neither cooling nor heating mode has been set	Does the "cooling / heating" symbol appear in the display?	Correct the settings for the unit
	Fins of outdoor unit are blocked by debris	Is the fan on the outdoor unit running are the fins unobstructed?	Check fan or winter regulation, reduce air resistance
	Leaking refrigerant circuit	Are there signs of frost on the fins of the indoor unit?	Repair by a specialist
Condensation output on the unit	Drain pipe of the collection container blocked / damaged	Is unobstructed condensation drainage ensured?	Clean the drainage pipe and collection container
	Faulty external condensation pump or float	Is the condensation pan full of water and the pump is not working?	Call out a specialist to replace the pump
	Condensation has not drained away and has collected in the condensation line	Is the condensation line routing sloped downhill and is it clear?	Route the condensation line in a downhill slope or clean it if necessary
	Condensation does not drain off	Are the condensation lines unblocked and is there a steady fall? Are the condensation pump and float switch functioning correctly?	The condensation line must have a fall. If necessary, clean the pipe. A faulty condensation pump and float switch should be replaced.
	Leaking refrigerant circuit	Are there signs of severe frost on the large stop valve?	Repair by certified service centre.

Problem display by blinker code

Display	Cause	Required action
E0	EEPROM error	Switch off the power to device for 1 min. Contact specialist dealer
E1	Communication error between outdoor unit and indoor unit	Contact specialist dealer
E2	Phase monitoring has responded	Check wiring
E3	Evaporator fan motor speed too low / defective	Contact specialist dealer
E5	Sensor discharge hot gas AT faulty / connection interrupted	Check connection and plug
E6	Sensor recirculated air IT faulty / connection interrupted	Check connection and plug
P0	Rotational speed monitoring on compressor has responded (Inverter module)	Check connections CN4, CN1 on the AT PCB / contact specialist dealer
P1	Overvoltage protection AT tripped (250V)	Check the voltage of the mains cable
P2	Excessive temperature (Klixon) compressor has tripped	Check refrigerant Check the resistance of the compressor sensor (normal 0Ω)
P3	Overcurrent compressor has responded	Check winding resistance of the compressor (1Ω = U-V / U-W / V-W)

Installation instructions for qualified personnel

Important points prior to installation

For installation of the entire system, observe the operating instructions of the indoor unit and the outdoor unit.

- Transport the unit in its original packaging as close as possible to the installation location. This avoids transportation damage.
- Check the contents of the packaging for completeness and check the unit for visible transport damage. Immediately notify any deficiencies to the contractual partner and forwarding agent.
- Lift the unit at the corners and not by the refrigerant or condensation connections.
- The refrigerant pipes (injection and suction pipe), valves and connections to make them tight against vapour diffusion. If necessary, also insulate the condensation line.
- Select an installation location which allows air to freely flow through the inlet and outlet (see section "Minimum clearances")
- Do not install the unit in the immediate vicinity of devices with intensive thermal radiation. Installation near sources of thermal radiation reduces the output of the unit.
- Install the refrigerant pipes from the indoor unit to the outdoor unit.

- Seal off open refrigerant pipes with suitable caps or adhesive strips to avoid the infiltration of moisture and never kink or compress the refrigerant pipes.
- Only use the union nuts for the refrigerant pipes included in the delivery, and remove them shortly before connecting the refrigerant pipes.
- Establish all electrical connections in accordance with the relevant DIN- and VDE standards.
- See electrical connection diagram Ensure the electrical cables are properly connected to the terminals, otherwise there is a risk of fire.

Installation material

The indoor unit is fastened using 4 threaded rods (provided by the customer) over a wall brace.

Selection of the installation location

The indoor unit is designed for horizontal wall installation above doors. However, it can also be used in the upper wall area (min. 1.75 m above the floor).

Minimum clearances

Observe the minimum clearances to allow access for maintenance repair work and for optimum air distribution.

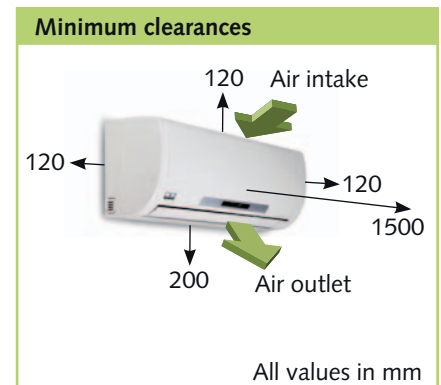

Connection variations

The following connection variations for the refrigerant, condensation and control lines can be utilized.

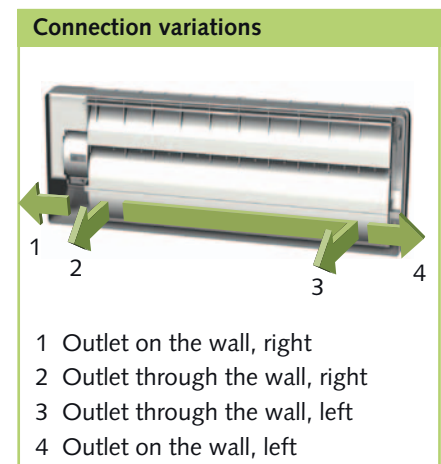

NOTE

There is an approx. 50 cm long pipe permanently installed from right to left in the indoor unit. This is to be taken into consideration when undertaking preinstallation work on site.

Installation



NOTE

Installation should only be performed by authorised specialists.

Unit installation

The indoor unit is attached by means of a wall bracket, under consideration of air discharge side located in the lower part.

1. Mark the mounting points on the statically permissible building sections according to the dimensions of the unit.
2. If necessary, remove the break out opening on the housing.
3. Connect the refrigerant pipes, electrical cables and condensation line to the indoor unit as described below.
4. Hang the indoor unit onto the wall bracket by tilting it back slightly and by pressing the bottom part of the unit against the bracket.
5. Check again to ensure that the unit is level (**Figure 4**).

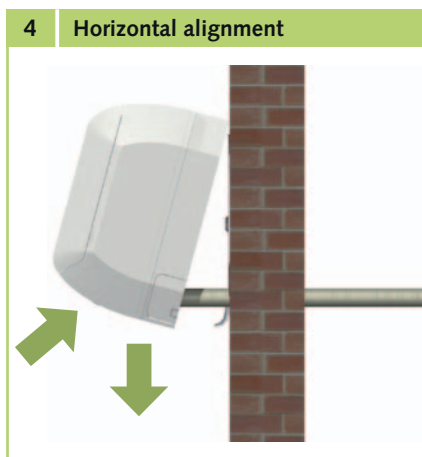

The wall bracket for the unit must be attached with suitable screws and anchors.

Connection of refrigerant pipes

The on-site connection of the refrigerant pipes is made at the rear of the unit.

If necessary, a reduction or expansion needs to be installed on the indoor unit.

These fittings are included as standard with the indoor unit.

Once installed, the connections should be insulated to make them vapour diffusion proof.



CAUTION

The units are factory filled with dry nitrogen to check for leaks. The pressurised nitrogen is released when loosening the union nuts.

Condensation connection

Due to the dew point shortfall, condensation forms on the vaporiser during the cooling operation on the indoor unit.

Below the vaporiser is a collection tray, which must be connected to a drain.

- The condensation line should have a fall of min. 2 %. (**Fig. 5**). If necessary, fit vapour diffusion proof insulation.
- The condensation line from the unit should run freely into the drainage pipe. If the condensation runs directly into a sewer pipe, install a trap to prevent any unpleasant odours.
- When operating the unit at outdoor temperatures below 0 °C, ensure the condensation line is laid to protect it against frost. If necessary, install a pipe heater.
- After completed routing, check for unobstructed condensation discharge and ensure that a permanent seal is provided.

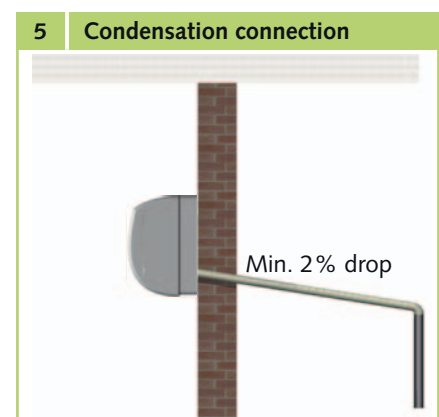

The condensation hose is designed to be installed on the left side (view from front).

Electrical connection

A protected mains supply cable is to be connected to the outdoor unit and 4-core control line is to be connected to the indoor unit respectively.

CAUTION

All electrical installation work should be performed by specialist contractors. Isolate the voltage supply when connecting the electrical terminals.

- We recommend to install a main / repair switch on the building near the indoor unit.
- The terminal blocks for making the connections are located at the rear of the unit. When the unit is installed, measurements can be made from the front by removing the cover.
- If an optional condensation pump is used in conjunction with the unit, it may be necessary to install an additional relay with a higher contact rating after the switch-off contact on the pump to switch off the compressor.

The device's scope of delivery includes a five metre long, four-core control line for connecting the indoor unit to the outdoor unit. The control line to the outdoor unit contains a data cable which serves to realise communication between the indoor unit and the outdoor unit. This is used for controlling the cooling and heating performance and for forwarding fault indications to the indoor unit. If the length is insufficient, you can extend these control lines on the indoor unit.

Make the connection as follows:

1. Open the air intake grill.
2. Unfasten the covers on the right side (**figure 6**).
3. Loosen the control line on the terminal block and remove the control cable.
4. Connect the control line that has been pre-prepared on-site to the terminal (**see electrical connection diagram S.20**).
5. Connect the on-site pre-prepared control line with the supplied control cable in a professional manner.
6. Insert the control line plug into the corresponding socket on the outdoor unit.
7. Re-assemble the unit.

6 Connecting the unit

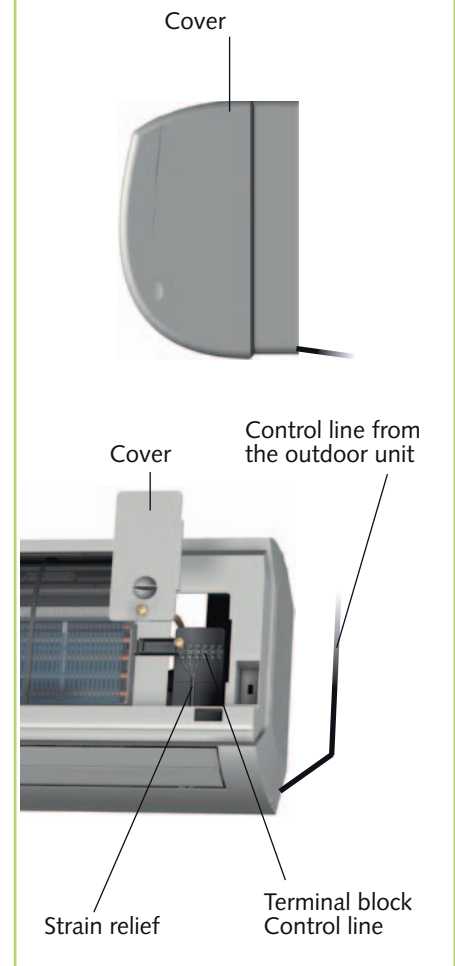

Electrical connection diagram

Connection MVT 600 DC / MVT 900 DC
MVT 950 DC / MVT 1050 DC

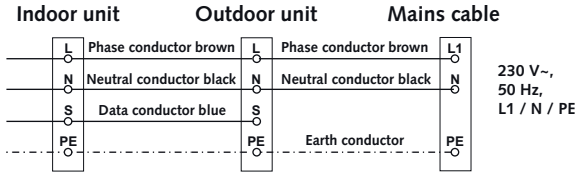

Electrical circuit diagram

MXW 200 to 520

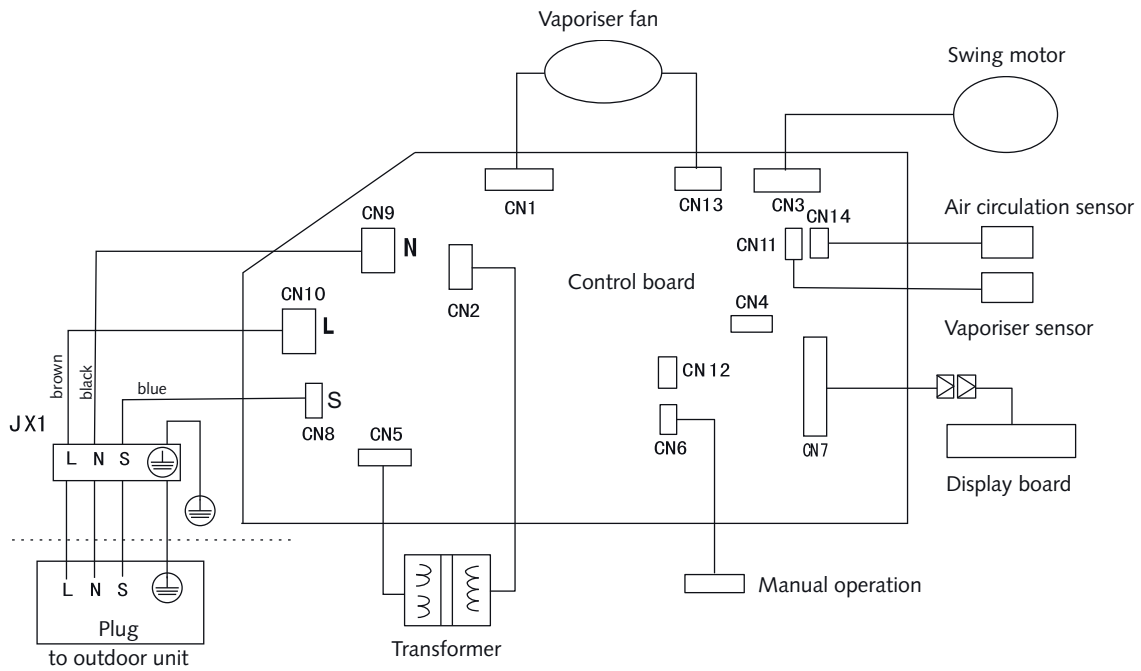

Commissioning

NOTE

Commissioning should only be performed by specially trained personnel and documented after the certificate has been issued.

Observe the manuals for the indoor unit and outdoor unit when commissioning the entire system.

4. Check the control system for the unit using the functions described in the chapter "Operation". Timer, temperature setting, fan speeds and changing to ventilation or dehumidification mode.
5. Check the correct function of the condensation line by pouring distilled water into the condensation tray. A bottle with a spout is recommended for pouring the water into the condensation tray.

3. Measure and record all the required values in the commissioning report and check the safety functions.
4. Check the control system for the unit using the functions described in the chapter "Operation". Timer, temperature setting, fan speeds.

Functional test for cooling mode.

1. Switch the supply voltage on.
2. Use the remote control to turn on the unit and select the cooling mode, maximum fan speed and lowest target temperature.
3. Measure and record all the required values in the commissioning report and check the safety functions.

Functional test for heating mode.

1. Switch the supply voltage on.
2. Use the remote control to switch on the unit and select the heating mode, maximum fan speed and highest target temperature.

Final tasks

- Re-fit all the dismantled parts.
- Familiarize the operator with the system.

NOTE

Check that the stop valves and valve caps are tight after carrying out any work on the refrigerant circuit. If necessary, use appropriate sealant products.

Unit dimensions

MXW 200 - 260

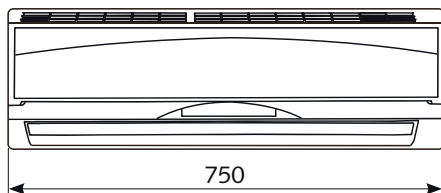

MXW 350

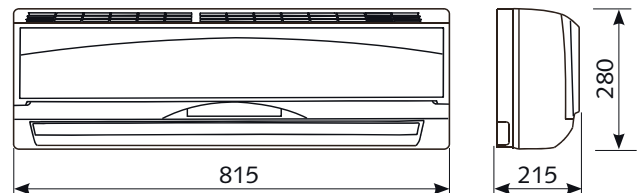

MXW 520

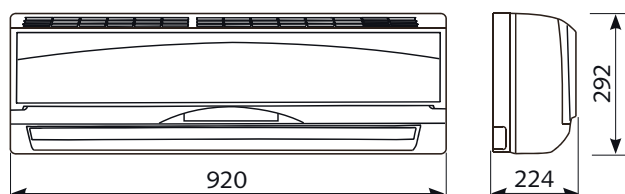

All values in mm

We reserve the right to modify the dimensions and constructional design as part of the ongoing technical development process.

Notizen

Area with 18 horizontal green lines for notes.

Exploded view MXW 200 / MXW 260 / MXW 350 / MXW 520

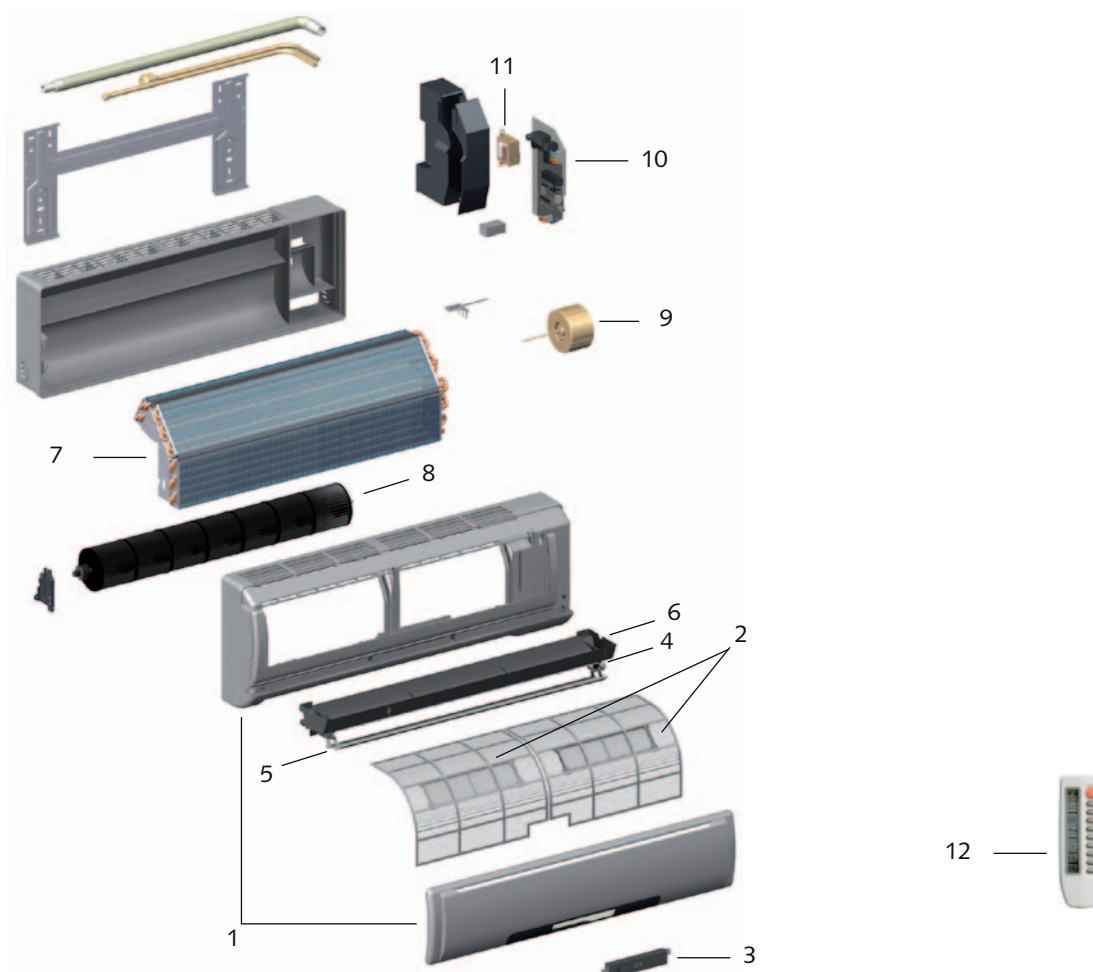

We reserve the right to modify the dimensions and constructional design as part of the ongoing technical development process.

Spare parts list

No.	Designation	MXW 200	MXW 260	MXW 350	MXW 520
1	Complete front face	111063	111001	111002	111089
2	Air filter, set	111064	111003	111004	111090
3	Board, display	111005	111005	111005	111091
4	Swing motor	111006	111006	111006	111006
5	Air outlet fins, set	111066	111007	111008	111092
6	Condensation tray	111067	111009	111010	111093
7	Vaporiser	111068	111011	111012	111094
8	Fan wheel	111069	111013	111014	111095
9	Fan motor	111015	111015	111016	111096
10	Control board	111070	111017	111018	111097
11	Transformer	111019	111019	111020	111098
12	IR remote control	111021	111021	111021	111021
Spare parts (not illustrated)					
	Air circulation sensor	111022	111022	111022	111022
	Vaporiser sensor	111023	111023	111023	111023

When ordering spare parts, please state the computerised part no., unit number and type (see identification plate)!

Technical data

Baureihe		MXW 200	MXW 260	MXW 350	MXW 520
Operating mode		Wall unit for cooling and heating			
Nominal cooling output ¹⁾	kW	2,05	2,61	3,53	5,23
Nominal heating output ²⁾	kW	2,41	2,86	4,11	5,56
Energy efficiency class, cooling ¹⁾		B	A	B	B
Energy efficiency class, heating ¹⁾		B	B	B	C
Energy efficiency ratio EER ¹⁾		3,18	3,21	3,18	3,04
Energy efficiency ratio COP ¹⁾		3,41	3,42	3,41	3,31
Power consumption, annual, (500h)	kWh	1290/1410	1120/1255	1290/1410	1727/1692
Operating range (room volume), approx.	m ³	60	80	110	160
Adjustment rangelroom temperature	°C	+17 to +30			
Working range	°C	+17 to +32			
Refrigerant		R 410A ⁴⁾			
Operating pressure max. / per cooling circuit	kPa	4200 / 4200			
Air flow rate per stage	m ³ /h	300/330/400	410/460/500	420/520/680	650/800/850
Noise output per stage ³⁾	dB (A)	29/33/35	32/34/36	28/33/39	36/39/41
Voltage supply	V/Hz	230 / 1~ / 50			
Protection degree	IP	X 0			
Nom. electrical power consumption, cooling ¹⁾	kW	0,04	0,04	0,05	0,05
Nom. electrical power consumption, heating ²⁾	kW	0,04	0,04	0,04	0,05
Electr. nominal power consumption cooling ¹⁾	A	0,17	0,17	0,19	0,24
Electr. nominal power consumption heating ²⁾	A	0,17	0,17	0,19	0,19
Refrigerant connection, injection pipe	Zoll (mm)	1/4 (6,3)	1/4 (6,3)	1/4 (6,3)	1/4 (6,3)
Refrigerant connection, suction pipe	Zoll (mm)	3/8 (9,52)	3/8 (9,52)	1/2 (12,7)	1/2 (12,7)
Condensation connection	mm	16	16	16	16
Dimensions Height	mm	250	250	280	290
Width	mm	750	750	815	920
Depth	mm	188	188	215	225
Weight	kg	8,5	8,5	10,0	12,0
Serial number		782...	780...	781...	779
Computerised part no.		1623205	1623200	1623210	1623215

1) Air intake temp. TK 27°C / FK 19°C, outdoor temp. TK 35°C / FK 24°C, max. air volume, 5m pipe length in combination with MVT 900 / 950 / 1050 DC

2) Air intake temperature TK 20°C outdoor temperature TK 7°C, FK 6°C, max. air volume, 5m pipe length in combination with MVT 900 / 950 / 1050 DC

3) Distance 1 m free air

4) Contains greenhouse gas according to Kyoto protocol

EC – Declaration of Conformity

in accordance with Machinery Directive appendix II 1A
Original declaration of conformity



We do hereby declare that the devices named below, produced and sold by us, satisfy the relevant basic requirements of the EC guidelines, the EC safety standards and other product-specific EC standards.

Name of Manufacturer: **REMKO GmbH & Co. KG**
Air conditioning and heating technology
Im Seelenkamp 12
D - 32791 Lage

Name of CE representative: **REMKO GmbH & Co. KG**
Air conditioning and heating technology
Im Seelenkamp 12
D - 32791 Lage

Equipment (machinery) - Implementation: **Inverter wall - room air conditioner in multisplit design**

Series / Model: REMKO MXW 200, MXW 260, MXW 350, MXW 520
Series / Class Number: 782..., 780..., 781..., 779...

Applicable regulations : (EC-Directive)	MA - RL 2006/42/EC	Machinery Directive
	NS - RL 2006/95/EC	Low-Voltage Directive
	EMV – RL 2004/108 EWG	EMV Directive
	EnVKV - RL 92/75/EEC	Energy consumption labelling directive
	EC 97/23/EC	Pressure Equipment Directive

Applicable Standards: DIN EN ISO 12100-1-2 : 2004-04;
DIN EN ISO 13857,
EN 14511 T1-4;
DIN 45635 - 1;
EN 378 – 1-4;
EN 55014 - 1; EN 55014 - 2; EN 55104
EN 60204 - 1; EN 60335 - 1 EN 60335 - 2 -40
EN 6100 - 3 - 2; EN 6100 - 3 - 3

Lage, 25nd February 2010

REMKO GmbH & Co. KG

.....
Signature Product Manager

REMKO INTERNATIONAL

*... and in your area!
Profit from our experience and advice*



Consultancy

Intensive training means our consultants are always up-to-date with the latest developments. This has given us the reputation of being more than just a good and reliable supplier:

REMKO, a partner who helps solve problems.

Sales

REMKO not only has a well-established sales network at home and abroad, it also employs highly trained sales specialists.

REMKO Our field staff are more than just salesmen: above all, they must advise our clients in the areas of air conditioning and heating technology.

Customer Service

Our equipment is precise and reliable. However, should a fault should occur REMKO customer service is quickly at your side.

Our comprehensive network of experienced dealers guarantees quick and reliable service.

REMKO GmbH & Co. KG Air conditioning and heating technology

Im Seelenkamp 12
Postfach 1827
Telephone
Telefax
E-mail
Website

D-32791 Lage
D-32777 Lage
+49 5232 606-0
+49 5232 606-260
info@remko.de
www.remko.de

Hotline
+49 5232 606-0

Export
+49 5232 606-130

