

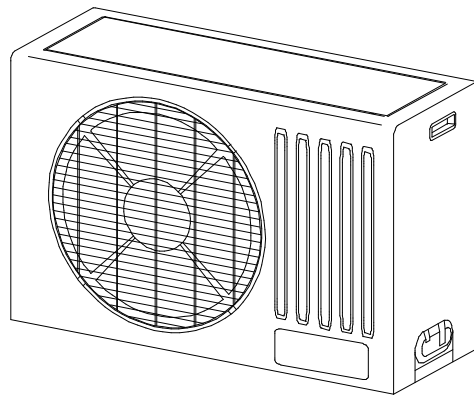

REMKO RKS 510 / 513 / 524
REMKO RKS 513 H / 524 H
Combi Air Conditioning Units



Operation
Technology
Spare Parts

Operating Instructions



Read these instructions carefully before setting up/operating the unit!

Our guarantee becomes null and void if the unit is used, set up
or maintained improperly,
or if modifications are made to the supplied unit without our prior consent.
Subject to alterations!

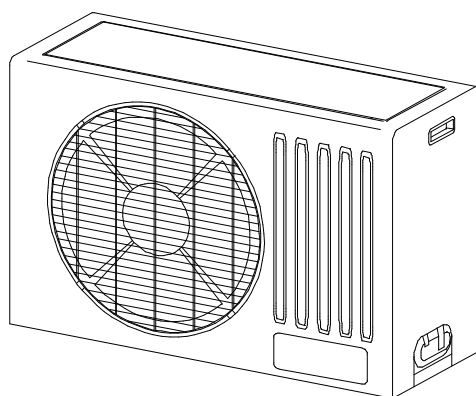
Combi Air Conditioning Units REMKO RKS 510 / 513 / 524 REMKO RKS 513 H / 524 H



Contents	Page	Contents	Page
Safety Hints	4	Impermeability Check	10
Transport and Packaging	4	Condensation	10
Description of Device	4	Electrical Connection	11
Operation	4	Winter Regulation	11
Combinations	5	Prior to Initial Operation	12
Shutting Down the Unit	5	Adding Refrigerant	12
Maintenance and Service	5	Initial Operation	12
Troubleshooting	5	Customer Service and Guarantee	13
Technical Data	6	Environment and Recycling	13
Dimensions	7	Wiring Diagram	13
Assembly Instructions for Service Personnel	7	Initial Operation Certification	15
Installation	9		

 Always keep these operating instructions near or on the unit! 

Safety Hints

Extensive tests have been conducted on the material, functionality and quality of these units before they were shipped. These units may only be used in accordance with their intended purpose. Hazards may arise if the units are used improperly.

Please make sure to follow these safety instructions.

- ◇ Make sure that personnel trained in the operation of the air conditioner check the unit for visible defects on the operating and safety mechanisms each time before putting it into operation.
- ◇ Before performing any work on the unit, the power cord must be unplugged and the unit secured against being switched on by unauthorised persons.
- ◇ Operate the units only when assembled and for their intended purpose.
- ◇ Keep in mind that it is dangerous to remove covers protective grilles, etc., during operation; this can lead to uncontrolled operating situations.
- ◇ Operate the units exclusively within the permissible operating ranges.
Pay attention to surrounding temperatures.
- ◇ Make sure that the unit is kept at a safe distance from flammable materials.
- ◇ Do not install the inside unit close to heaters or behind curtains and drapes.
Maintain the minimum safety distances indicated!
- ◇ Ensure that the air intake and outlet openings are always clear of foreign objects.
- ◇ Do not insert any objects into the air intake and outlet openings and do not place any objects on top of the units.
- ◇ The outdoor part may only be connected to a correctly installed and grounded power supply.
- ◇ Never operate the units in rooms susceptible to explosions. The units are also not suitable for operation in rooms containing large amounts of dust or aggressive air.
- ◇ Do not use flammable sprays such as hair spray or spray paint in the direct vicinity of the units.
- ◇ Do not operate the units if the atmosphere is contaminated by oil, sulfur or salt.
- ◇ Do not expose the unit to direct streams of water.
High-pressure cleaners, etc.
- ◇ The device is only guaranteed to operate optimally at temperatures between – 15 and + 46 °C.
- ◇ Never open the units' housing.
There may cause an electric shock.
- ◇ Protect the connection lines from being damaged, for example, by animals.
- ◇ All REMKO air conditioners are supplied with the environmentally-friendly refrigerant R 407 C.

- ◇ Make sure that the outdoor part is equipped with a safety mechanism which prevents condensation damage caused by the unit switching back on right away after it has been switched off
The unit may only be switched back on after 3 min.
- ◇ Cleaning and minor maintenance work made only be performed by the operator or an authorised person designated by him in accordance with the instructions contained in the section "Maintenance and Service".
- ◇ Installation and repair work may only be performed by authorised personnel.

Transport and Packaging

The unit is shipped in a stable transport box made of cardboard. Please examine the unit when it is delivered.

Make note of any damage or missing parts on the shipping bill and notify the shipping company and your contract partner. We do not assume any liability for subsequent complaints.

Description of Device

The function of the outside part of the Combi Air, split-design air conditioners is to expel the warmth removed by the indoor unit from the room to be cooled to the outside air.

The way the air conditioning system works is quite simple; the indoor unit removes warmth from the room to be cooled. The environmentally-friendly refrigerant R 407C transports this warmth just as it does for all other REMKO air-conditioning products.

The outdoor part consists of a compressor, a plate fin condenser and a throttle mechanism. The outdoor part can be combined with a wall, cabinet or case unit that has the corresponding cooling capacity. The outdoor part is regulated via the indoor unit.

The RKS 513 H and RKS 524 H models work as air-cooled heat pumps in combination with the wall units RKV 13 WH and RKV 24 WH. It is possible to use the units for heating in spring and fall.

Operation

The outdoor part is controlled via the indoor unit. For this reason, it is necessary to read the section "Operation" in the operating instructions for the indoor units.

Combinations

	RKS 510	RKS 513	RKS 524
RKV 10 W	●		
RKV 13 W		●	
RKV 24 W			●
RKV 10 K	●		
RKV 13 K		●	
RKV 24 K			●
RKV 13 T		●	
RKV 24 T			●
		RKS 513 H	RKS 524 H
RKV 13 WH		●	
RKV 24 WH			●

Shutting Down the Unit

Temporary shutdown

1. Switch the system off using the remote control and disconnect the main switch or fuse protection from the power supply.
2. Check the outdoor part for visible damage.
3. Clean the outdoor part as described in the section "Maintenance and Service" and, if possible, cover it with a plastic sheet to protect it from weather conditions.

Troubleshooting

This unit has been designed based on state-of-the-art manufacturing methods and it has been tested repeatedly to ensure that it is working properly. However, should problems occur, refer to the following list.

Please keep in mind that the outdoor part is controlled via the indoor unit. As a result, we recommend also reading the section "Troubleshooting" in the operating instructions for the indoor unit.

Should the unit still not work after performing these functional checks, please contact an authorised service centre.

Problem	Possible cause	Check	Remedy
The unit does not start or it switches itself off automatically.	Main switch is off	Are all currents for lighting functional?	Turn on main switch
	Power fuse / power supply defective	Are all other electrical components working?	Maintenance by authorised personnel
	Amount of time waited after switching unit on was too short	Did the unit restart after approx. 5 min.?	Plan for longer waiting periods
	Operating temperature too low / too high	Are the units' fans working?	Pay attention to temperature ranges
	Voltage occasionally too high or too low	Checked by a service centre?	Switch the system off and then back on again
	Disabling contact of the external condenser pump is open	Is the external condenser pump of the indoor unit malfunctioning?	Clean condenser pump outlet / replace pump
The device is either not cooling at all or only a little bit	Intake / outlet opening is blocked by foreign bodies	Are there foreign bodies in the intake or outlet areas?	Clean plate fins / reduce air resistance
	Increased amount of warm air or wind	Has there been a change in the design or use of the unit?	Reduce the amount of warm air or wind
	Not possible to expel warm air	Is the outdoor part's fan working?	Check fan / winter regulation mechanism
	Cold cycle is not leak proof	Is there a strong buildup of frost visible on the large shut-off valve?	Maintenance by authorised personnel

Permanent shutdown

For environmental safety reasons, the air conditioners may only be disassembled by authorised service centres. REMKO GmbH & Co. KG or your contract partner would be happy to provide you with the name of a service centre in your area.

Maintenance and Service

Regular care and the observation of a number of basic rules will ensure the unit long service life and reliable operation.

 **Before any work on the unit is performed, it must be disconnected from the power supply and secured against switching on!**

- ◇ Keep the unit free of dirt, plants and other deposits and only clean the units with a damp cloth.
Do not expose the units to a direct stream water.
- ◇ Do not use an abrasive cleaning agent or one that contains solvent; if the units are extremely dirty, only use suitable cleaning materials.
- ◇ Before taking the unit out of operation for a longer period of time, clean the plate fins of the outside part while the ventilator is in operation and cover the outdoor part with a plastic sheet to prevent dirt from entering the unit.
- ◇ We recommend concluding a maintenance agreement with a company who specialises in this type of work.
This will guarantee that the system operates safely at all times!

Technical Data

		RKS 510	RKS 513	RKS 524	RKS 513 H	RKS 524 H
Cooling capacity *	W	2900	3800	6800	3800	6800
Heating capacity **	W	-	-	-	4000	7200
Working range (size of room)	approx. m ³	90	120	230	120	230
Operating range outside temperature	°C	- 15 to + 46				
Air performance max.	m ³ /h	2050	2050	4100	2050	4100
Refrigerant		R 407 C				
Refrigerant amount	g	1500	1500	2300	1500	2300
Refrigerant pressure max. / min.	kPa	2800 / 500				
Connection injector line	inch (mm)	3/8 (9.52)				
Connection suction line	inch (mm)	1/2 (12.7)		5/8 (15.9)	1/2 (12.7)	5/8 (15.9)
Length of line / height difference, max.	m	15 / 10				
Additional amount to add for 5 m and longer	g/m	18				
Electrical connection	V / Hz / Ph	230 / 50 / 1~, N, PE				
Type of protection	IP	X4				
Power consumption cooling, max.	W	880	1150	2300	1150	2300
Power consumption heating, max.	W	-	-	-	1170	2320
Nominal current consumption, max.	A	4.5	6.16	12.9	6.16	12.9
Starting current LRA	A	23	31	77	31	77
Supplied fuse protection (recommended)	A	16	16	25	16	25
Sound pressure level, max. ***	dB(A)	49	49	59	49	59
Dimensions Height	mm	615	615	645	615	645
Width	mm	850	850	950	850	950
Depth	mm	322	322	417	322	417
Weight	kg	46	46	72	46	72
Manufacturer number		382...	383...	384...	385...	386...
Ref. No.		1613570	1613540	1613550	1613545	1613555

* The capacities are based on ISO R859A: room temperature dry-bulb 27 °C; wet-bulb 19 °C – outside temperature 35 °C

** The specified heating capacity can only be achieved in combination with the indoor units RKV 13 WH and RKV 24 WH.

*** L_{pA} 1m noise measurement DIN 45635 - 01 - KL3

Heating capacities

Outside temperatures		10 °C db 9 °C wb	7 °C db 6 °C wb	4 °C db 3 °C wb	0 °C db -1 °C wb	-4 °C db -6 °C wb	-7 °C db -8 °C wb
RKS 513 H	Heating capacity W *	3,305	2,990	2,580	2,175	1,825	1,695
	Electrical capacity W *	1,065	900	895	865	840	835
RKS 524 H	Heating capacity W *	3,995	3,870	3,190	2,725	2,235	2,005
	Electrical capacity W *	1,300	1,180	1,135	1,075	1,015	970

* At a room temperature of 20 °C

Dimensions

RKS 510, RKS 513, RKS 513 H

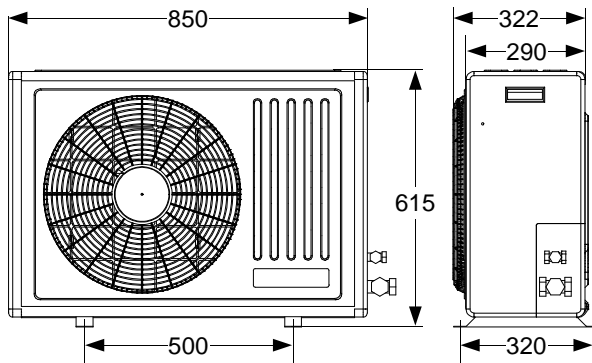

RKS 524, RKS 524 H

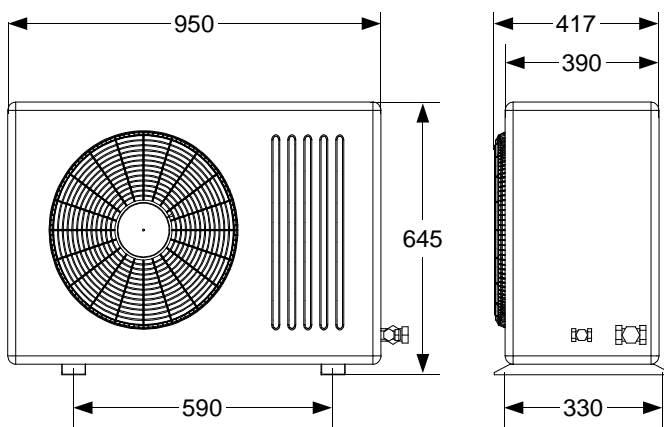

Assembly Instructions for Service Personnel

Prior to installation

To avoid having an adverse effect on the performance of the air conditioner, several basic rules must be observed when setting up the outdoor part and installing the refrigerant lines:

- ◇ Make sure that the refrigerant line is no longer than 15 m with a maximum height difference of 10 meters.
- ◇ Add more refrigerant to the system when the basic length of the refrigerant line exceeds 5 m.
The required amounts of additional refrigerant are indicated in the section "Adding Refrigerant".
- ◇ Make sure that the indoor unit and the outdoor part of the system have been adjusted to one another from a technical standpoint.
The guarantee becomes null and void if third-party components are used.
- ◇ Ensure that the contents of the package are complete and that the unit has no visible damage results in from transport.
- ◇ Any problems must be communicated immediately to your contract partner and the shipping company. Subsequent complaints will not be acknowledged.

- ◇ Place the unit in its original packaging as close as possible to the location where it will be assembled.
This will prevent damage resulting from transport.
- ◇ Prior to installation, the electrical connection values must be checked for consistency with the data on the type plate.
- ◇ Remove the protective caps of the unit connections just before connecting the refrigerant lines.
- ◇ Do not bend or press on the refrigerant lines.
- ◇ Remember that when installing and maintaining air conditioners, high pressure and electrical current can pose hazards.
- ◇ Be especially careful when covers are removed.
The components in the cold cycle can reach temperatures of more than 70 °C.
- ◇ Select a location to set up the unit where air can flow freely in and out of the device.
Minimum distances that must be maintained for safety purposes are provided in the section "Minimum Distances".
- ◇ The power supply may only be connected to the outdoor part. The control lines to the indoor units should be laid at the same time as the refrigerant lines.
- ◇ The electrical connections must meet the relevant DIN and VDE standards.
- ◇ Make sure that all refrigerant lines including all connectors and valves are insulated against heat and sealed against diffusion.

Preventable installation mistakes

When performing the installation, make sure to observe the following:

- ◇ Place the lines between the indoor unit and the outdoor part, keeping the length of the refrigerant lines as short as possible.
- ◇ The cooling connection valve may only be opened once installation is complete.
- ◇ Always secure electrical lines properly in the electrical clamps.
Not doing so could cause a fire.
- ◇ Seal open refrigerant lines with suitable caps and/or adhesives to prevent moisture penetration.
- ◇ Avoid bending the lines unnecessarily.
This minimises pressure loss in the refrigerant lines and guarantees that the compressor oil can flow freely.
- ◇ If the outdoor part is mounted above the indoor unit, you must take steps to recirculate the oil.
See section on oil recirculation.
- ◇ Do not set up the unit in the direct proximity of devices that emit intense heat, such as glass reflection surfaces.
If the unit is assembled close to heat emissions, the amount of warm air expelled by the plate fins of the outdoor part is reduced.

Wall lead-throughs

Wall lead-throughs are necessary to establish the connection between the indoor unit and the outdoor part. Please observe the following:

- ◇ For the connection line to the outdoor part, a lead-through of at least 70 mm in diameter per cold cycle must be created.
- ◇ The lead-through must be placed at an incline of at least 10 mm between the inside and outside.
- ◇ Before beginning work, make sure that there are no supply lines (water, etc.) located in the vicinity of the wall lead-through.
- ◇ We recommend cushioning the inside of the hole or lining it with a PVC pipe to prevent damage to the lines.

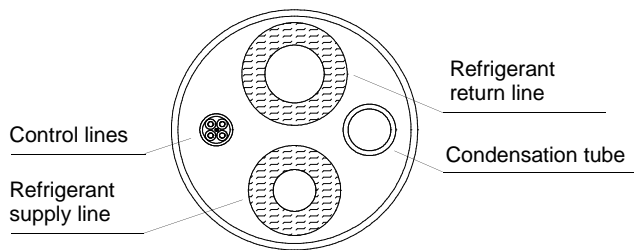

- ◇ After assembly is complete, the wall lead-through must be sealed with a suitable sealing compound. *Do not use any materials containing cement or lime!*

Minimum distances

The figure below indicate the minimum distances that must be maintained to ensure that the units operate properly.

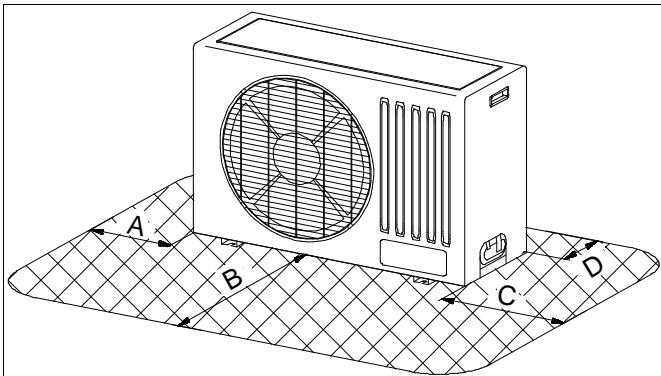

These safety zones ensure that air can flow freely in and out of the unit, that maintenance and repair work can be performed and to protect the unit from damage.

	RKS 510	RKS 513	RKS 524
A	200 mm	200 mm	300 mm
B	700 mm	700 mm	900 mm
C	400 mm	400 mm	400 mm
D	100 mm	100 mm	200 mm

Location of installation for the outdoor part

The outdoor part must be set up on a surface that is level, smooth and solid.

The outdoor part can either be set up outside or inside a building. If it is set up outside, follow these instructions to protect the unit from weather conditions.

Rain:

If the outdoor part is set up on the ground or a roof, there must be at least 10 cm (measurement X in the illustration below) between it and the surface.

A base console can be purchased as an accessory.

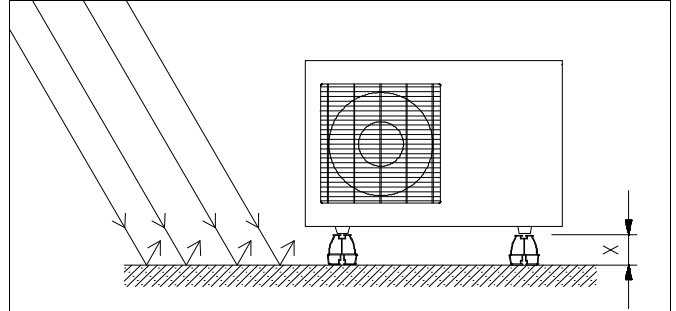

This prevents dirt and rust caused by splashing rain.

Sun:

The plate fin exchanger (condenser) on the outdoor part is a heat-emitting component.

Direct sunlight also increases the temperature of the plate fins and reduces the amount of heat expelled by the plate fins exchanger.

If possible, the outdoor part should be installed on the north side of the respective building.

A small structure should be set up to provide shade for the unit and protect it from the sun if necessary. However, it must not be allowed to interfere with the flow of hot air being released from the unit.

Wind:

If the outdoor part is operated primarily in windy areas, make sure that the hot air current being released from the outdoor part is flowing in the primary wind direction.

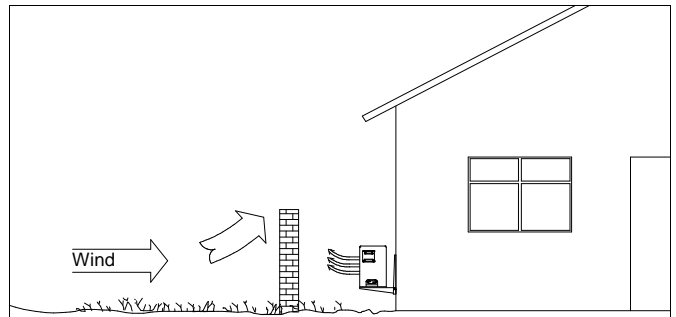

If this is not possible, you should provide protection from the wind. Make sure that the wind protection does not adversely affect the flow of the air to the unit.

Snow:

The outdoor part should be installed on the wall in areas with heavy snowfall.

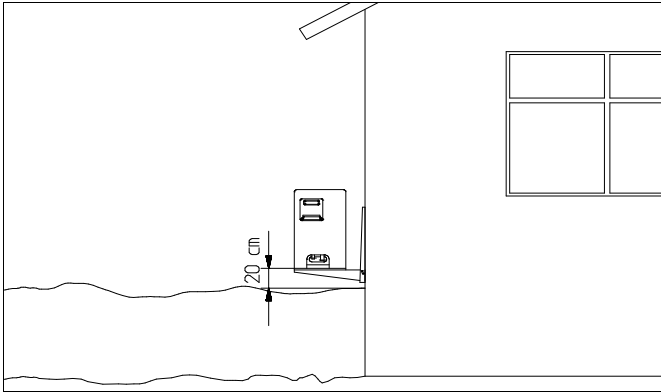

The outdoor part should be installed at least 20 cm above the expected snow level to prevent snow from entering the outdoor part.

A wall console can be purchased as an accessory.

Installation inside buildings:

If the outdoor part is set up inside a building, observe the following.

- ◇ If the outdoor part is set up in a basement, an attic, in adjoining rooms or halls, make sure that the warm air can be adequately released.
- ◇ Install an additional fan that has the same air volume current at its disposal as the outdoor part set up in the room which can potentially compensate for additional pressure losses through air channels.

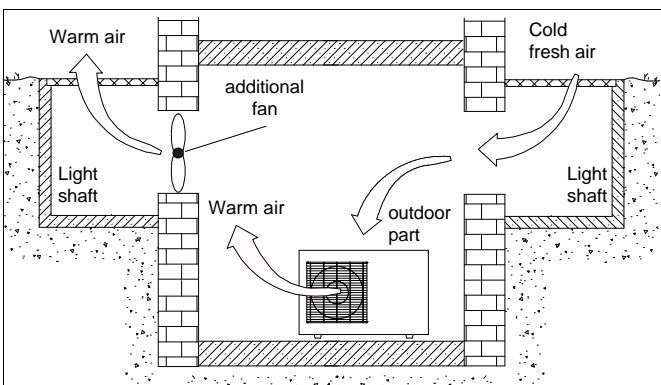

- ◇ Make sure that air can be freely supplied from the outside, if possible through air openings opposite the unit that are sufficiently large.
- ◇ Ensure that there is adequate soundproofing to prevent excessive noise in residences.
- ◇ Never block or shut the intake grille.
- ◇ Observe the static and other structural engineering regulations and requirements for the building.
- ◇ Do not set up the unit in areas with lots of dust or aggressive air.

Installation

The following instructions describe installation of the cold cycle and the assembly of the indoor unit and outdoor part.

1. The required cross-sections are provided in the "Technical Data" table.
2. Install the indoor unit and connect the pipe line as described in the operating instructions for the indoor unit.
3. When assembling the unit, observe the bending radii of the refrigerant lines and never bend the pipe in the same place twice.
This may cause the line to become brittle or crack.
4. Place the refrigerant lines between the indoor unit and the outdoor part.
Make sure that they are securely fastened and take steps to recirculate the oil!
5. Install the outdoor part with the wall or base console onto stationary building parts approved for this purpose.
Follow the installation instructions for the consoles.
6. Make sure that no structure-borne sound is transmitted to parts of the building.
Structure-borne sound can be reduced through vibration absorbers!
7. Remove the protective caps supplied and the screw caps of the shut-off valves and use these for continued assembly.
8. Before you flare the refrigerant lines, make sure that the screw cap is placed on the pipe.
9. Work with the refrigerant lines as shown in the figure below.

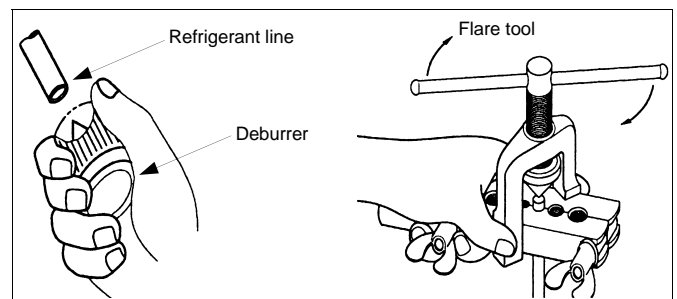

Only tools approved for use in cold conditions may be used.

Tube cutter, deburrer and flare tool.

10. Check that the flare has the correct shape.

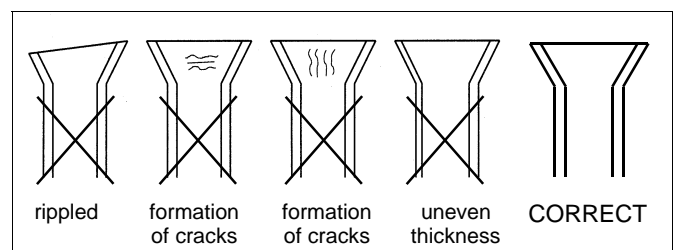

11. First manually connect the refrigerant lines with the shut-off valves to ensure that they are in the proper position.

Check that the suction and pressure lines of the cold cycle have been correctly allocated!

12. Now tighten the bolts using 2 wrenches with a sufficiently wide opening.
Use a second wrench to apply counterpressure when tightening (see figure)

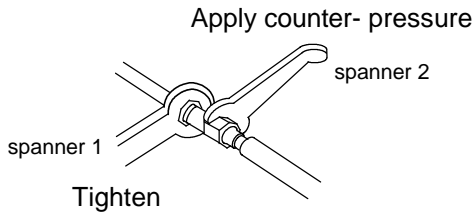

13. Insulate both the installed refrigerant lines and the connector against heat.
14. Only use insulation hoses suitable for this temperature range that are sealed against diffusion.

Additional installation instructions

- ◇ When the outdoor part is used in combination with various other indoor units, the connection to the refrigerant lines can be different. If this is the case, attach the reduction or expansion fittings supplied to the indoor unit.

If the length of the connection line is longer than 5 m, refrigerant must be added to the system during initial operation.
See the section entitled "Adding Refrigerant"

Oil recirculation

If the outdoor part is set up at a higher level than the indoor unit, appropriate steps must be taken for oil recirculation.

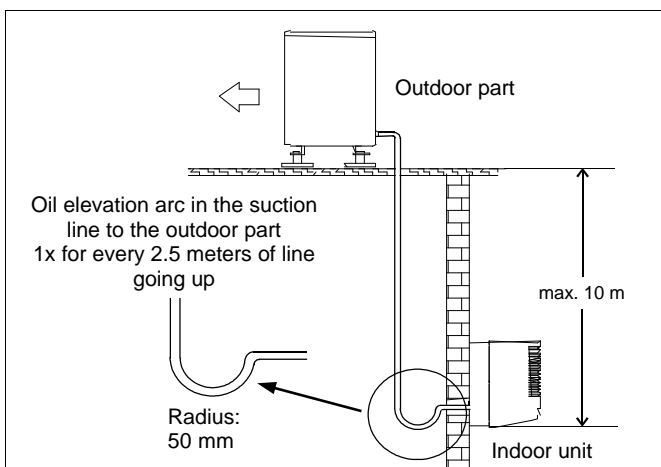

This is usually accomplished by creating an oil elevation arc that is installed every 2.5 meters of line going up.

Impermeability Test

Once all connections have been made, the manometer station is connected to the corresponding valve connections as described below:

- red = small valve = injection pressure.
- blue = large valve = suction pressure.

After the connection has been made, an impermeability test is conducted using dry nitrogen.

The connections that have been established are sprayed with a leak locator spray to test for impermeability. Tighten the bolts more firmly or, if necessary, create a new flare.

After this test has been successfully conducted, any excess pressure is removed from the refrigerant lines and a vacuum pump with an absolute final partial pressure of at least 0.01 mbar is put into operation to create a vacuum in the lines. This also removes any moisture from the lines.

A vacuum with a minimum of 0.05 mbar must be created!

How long it takes to create the vacuum is based on the pipe line volume of the indoor unit and the length of the refrigerant lines. However, this process takes a minimum of 30 minutes.

Once foreign gases and moisture have been completely removed from the system, the manometer station valves are closed and the valves of the outdoor part are opened as described in the section "Initial Operation".

Condensation

Because temperatures below the dew point are reached, condensation forms during heating operation on the plate fin exchanger of the outdoor part.

The lower housing case of the outdoor part is designed to function as a drain tray. Beneath the condenser, there is an opening where the condensation can drain out.

If the unit is used for heating in areas susceptible to frost, the lower housing case must be kept free of frost to ensure that the condensation can always drain out.

Condensation can also be drained via alternative routes using the supplied condensation hose. When laying the condensation hose, you must observe the following:

- ◇ Make sure that there is an adequate incline for drainage.
Minimum of 2 %.
- ◇ When the unit is in operation at an outside temperature of below 0 °C, the hose must be protected against frost.
If necessary, use a hose heating mechanism.
- ◇ Always use suitable hose clips.
- ◇ After the hoses have been put into place, you must check that the condensation flows freely.

Electrical Connection

A power supply to the outdoor part must be installed as well as a 4-wire control line for pure cooling operation from the outdoor part to the indoor unit.

A 7-wire and a 2-wire control line is required between the outdoor part and the indoor unit for cooling / heating operation.

These electrical installations may only be performed by authorised service personnel in accordance with the relevant regulations.

Local guidelines for operation as well as the requirements established by local energy supply companies must be observed for install and initial operation.

The connections of the outside part are located inside the unit above the connection valves.

The power supply's wire cross section is based on the design specifications and the connection capacity of the unit.

For the control circuit, we recommend using shielded lines with a wire cross section of at least 1.5 mm².

Prior to performing any work on the unit, it must be unplugged from the power supply and secured against being inadvertently switched on!



Connecting the outdoor part

Before proceeding with the connections, please read the following instructions:

- ◇ The connection box must be installed close to the outdoor part.
We recommend using a main switch or a repair switch.
- ◇ Power for the indoor unit is supplied via the connection line from the outdoor part.
- ◇ Fuse protection for the system occurs in accordance with the technical data.

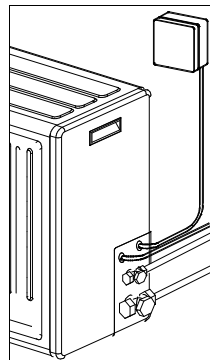

Proceed as follows to connect the line

1. Disassemble the unit cover by removing the fixing screws.
2. Remove the side panel where the connection is located.
3. Select the wire cross section of the connection line based on the respective requirements.
4. Guide both lines through the rubber protective rings of the fixed connection plate.
5. Clamp the lines as shown in the wiring diagram on page 13.
6. Place the line securely in the strain relief and reassemble the unit.

Winter Regulation

To ensure that the system functions properly, the pressure and temperature of the refrigerant must be kept within the operating ranges in the indoor unit and outdoor part. The integrated winter regulation mechanism makes it possible to keep operating ranges constant even when outside temperatures go as low as -15 °C.

The winter regulation mechanism gradually adjusts the condenser ventilator's motor speed depending on the operating pressure of the system and outside temperature. For this reason, the rotating motion of the ventilator can be completely discontinued in winter.

The regulating mechanism consists of a regulating board in a housing and a temperature sensor. The sensor records the temperature of the air entering the condenser.

The regulating board regulates the starting voltage for the ventilator depending on the regulating hysteresis set by the two jumpers (JP).

Adjusting the regulating hysteresis with the jumpers

HVS = Highest Ventilator Speed

HVS is the maximum ventilator speed for ventilation. It is also called **Effective Proportional Band (EPB)**.

LVS = Lowest Ventilator Speed

LVS is the design-specific, minimum ventilator speed when the regulating board has a starting voltage of 35%. It is also called the **Fixed Ventilator Voltage (FVV)**.

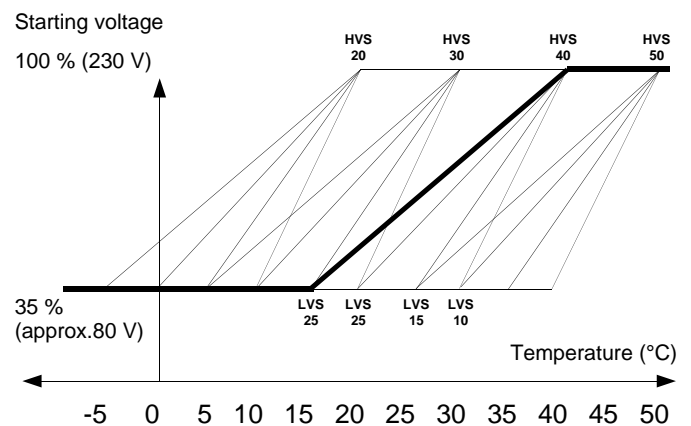

LVS		HVS	
JP 1	10	JP 5	20
JP 2	15	JP 6	30
JP 3	20	JP 7	40
JP 4	25	JP 8	50

Example:

Jumper JP 4 (**LVS**) and JP 7 (**HVS**) are plugged in.

- ◇ The maximum ventilator speed is reached at a temperature of 40 °C.
- ◇ The minimum ventilator speed is set at a temperature of 15 °C.

Prior to Initial Operation

After the impermeability check has been performed, the vacuum pump must be connected to the valve connections of the outdoor part by means of the manometer station and a vacuum created.

Prior to initial operation of the unit and after contact with the cold cycle, the following checks must be performed and documented in the initial operation log:

- ◇ Check all refrigerant lines and valves for leaks with a leak locator spray or soapy water.
The unit must be shut down.
- ◇ Check the connection lines to ensure that suction and injection lines have not been reversed.
- ◇ Check the refrigerant lines and insulation for damage.
- ◇ Check the electrical connection between the indoor unit and the outdoor part for the correct polarity.
- ◇ Check all fixtures and suspended parts to ensure that they are in the proper position and at the correct height.

 **If the refrigerant line is longer than 5 m, more refrigerant should be added to the system.**

Adding Refrigerant

The refrigerant required for operating the system is located in the outdoor part.

For refrigerant lines longer than 5 m per cycle, refrigerant must be added using the following table:

Length of line	Amount per meter
Up to and including 5 m	—
5 m to max. 15 m	30 g/m

Proceed as follows to add additional refrigerant:

1. Remove the vacuum pump and connect the filling cylinder.
2. Place the open cylinder on a scale and calibrate the scale to zero.
3. Create a vacuum in the hose at the height of the manometer distribution pipe.
4. Use the table above to determine the quantity to add.
5. Open the suction pressure side of the manometer.
6. Close the manometer valve when the appropriate amount has been added.

Initial Operation

Initial operation of the unit must comply with the certification specifications and must be documented.

Prior to handover

After all components have been connected and checked, the system can be put into operation.

To ensure that the unit is functioning properly, a functional check must be performed to identify any irregularities during unit operation before the unit is handed over to the operator.

This check is dependent on the installed indoor unit. These procedures are documented in the operating instructions of the indoor unit in use

Functional check and test run

The functional checks are started via the indoor unit. The indoor unit runs in standard cooling operation for the test.

The following must be checked:

- ◇ Check refrigerant lines for leaks.
- ◇ Check that the ventilator and compressor are running smoothly.
- ◇ Check that cold air is being expelled from the indoor unit and warm air from the outdoor part.
- ◇ Conduct a functional test of the indoor unit and all program processes.
- ◇ Check the surface temperature of the suction line and determine the evaporator overheating.
To measure the temperature, hold the thermometer on the suction line and subtract the boiling point temperature recorded on the manometer from the measured temperature.
- ◇ Document the measured temperatures in the initial operation log.

Proceed with the test run as follows:

1. Remove the caps from the valves.
2. To begin initial operation, briefly open the shut-off valves until the manometer displays pressure measuring approx. 2 bar.
3. Check the impermeability of all established connections with a leak locator spray or suitable devices.
4. If you did not find any leaks, open the shut-off valves by turning them all the way counter-clockwise with a hexagonal spanner.
If you found leaks, the connection must be re-established. It is absolutely necessary to create a new vacuum and dry the unit!
5. Turn the main switch or the fuse on.
6. Adjust the target temperature on the indoor unit to a lower value than the existing room temperature using the remote control.
7. Switch the indoor unit to cooling mode.

 **The compressor starts a couple of minutes later due to the delayed start of the outdoor part.**

8. During the test run, check all regulating, control and safety mechanisms to ensure that they are functioning and set properly.
9. Check the indoor unit's control mechanism using the functions described in the operating instructions. *Timer, temperature settings, fan mode and dehumidifying mode as well as all other mode settings*
10. Measure overheating, outside, inside, outlet and evaporation temperatures and enter these values in the initial operation log.
11. Remove the manometer and reattach all parts that were removed
Make sure that there are seals in the closing caps.

Customer Service and Guarantee

For the guarantee to be valid, the purchaser or his customer must completely fill out the "guarantee certificate" enclosed with all units and send it back to REMKO GmbH & Co. KG.

The units are repeatedly tested at the production site to ensure that they are working properly. If a malfunction occurs that cannot be eliminated by the operating personnel, please contact your dealer or contact person.

 **Operation/handling which does not comply with these instructions is prohibited!**
In cases of non-compliance, we assume no liability and the guarantee becomes null and void.

Proper use

The outdoor parts have been designed and fitted exclusively for operation with REMKO indoor units belonging to the RKV series.

The manufacturer assumes no liability for damage resulting from non-compliance with manufacturer specifications and legal requirements, or if modifications are made to the units.

Environment and Recycling

 **Important information about recycling!**

Only authorised personnel may come into contact with the cold cycle. This ensures that refrigerant does not escape into the environment when the unit is being repaired.

Both the refrigerant and the system parts are subject to special requirements for disposal.

 **The refrigerant in use is a safety refrigerant. This means that, should damage occur, the quantities released will not cause injury to the respiratory systems of people and animals. Do not touch the liquid refrigerant as it can freeze the skin!**

Wiring Diagram

Cooling units RKV-K, RKV-W, RKV-T

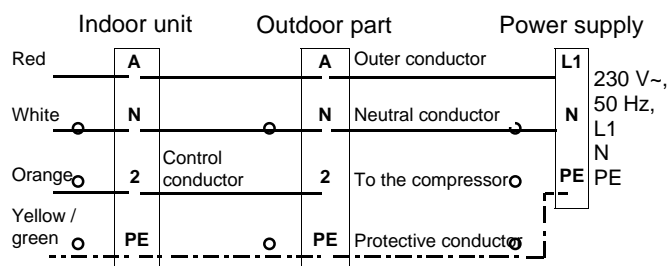

Connections of the indoor unit RKV-K

The clamps of the indoor units can have different names depending on the type of unit. The clamps of the RKV-K unit have the following names:

RKV-K	Description	Outdoor part
R	Outer conductor	A
C	Neutral conductor	N
Y	Control conductor compressor-contactor	2
PE	Protective conductor	⏚

Cooling / Heating units RKV 13 WH, RKV 24 WH

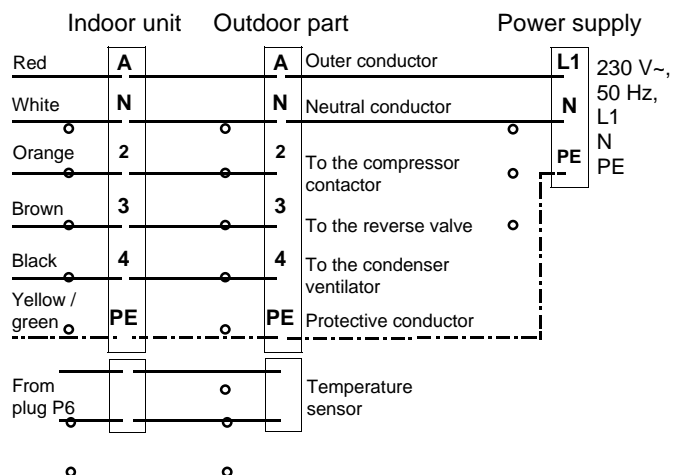

Internal wiring diagram

Cooling units RKV-K, RKV-W, RKV-T

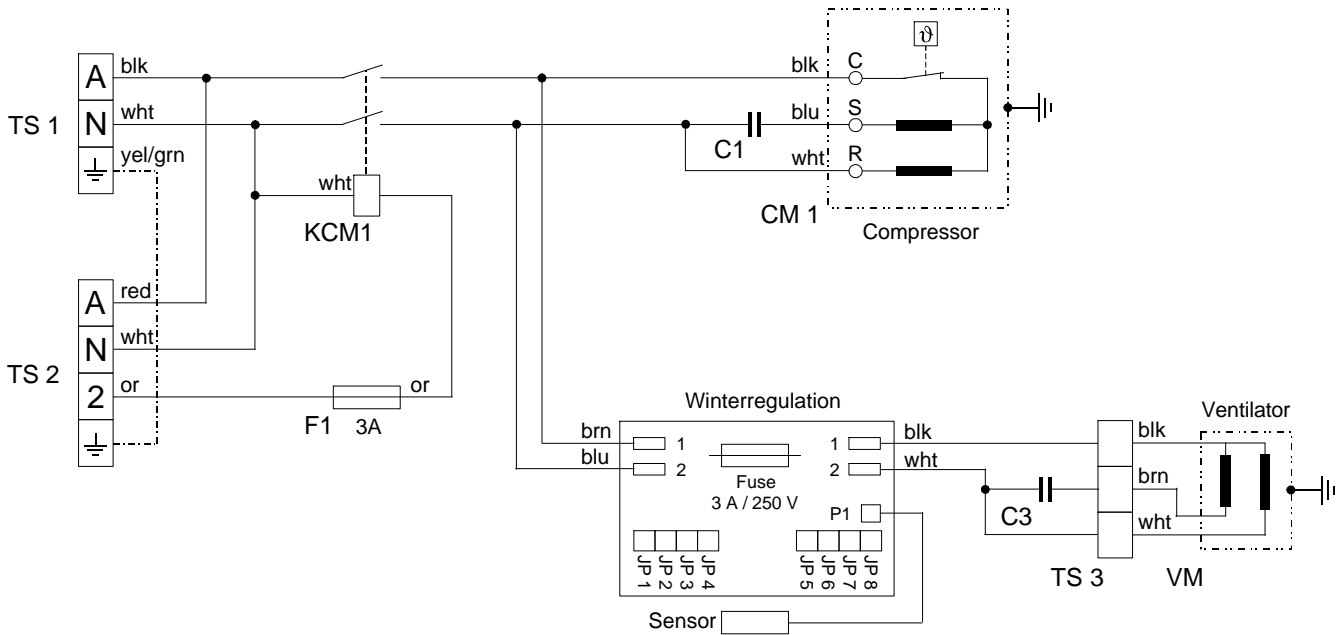

Internal wiring diagram

Cooling / Heating units RKV 13 WH, RKV 24 WH

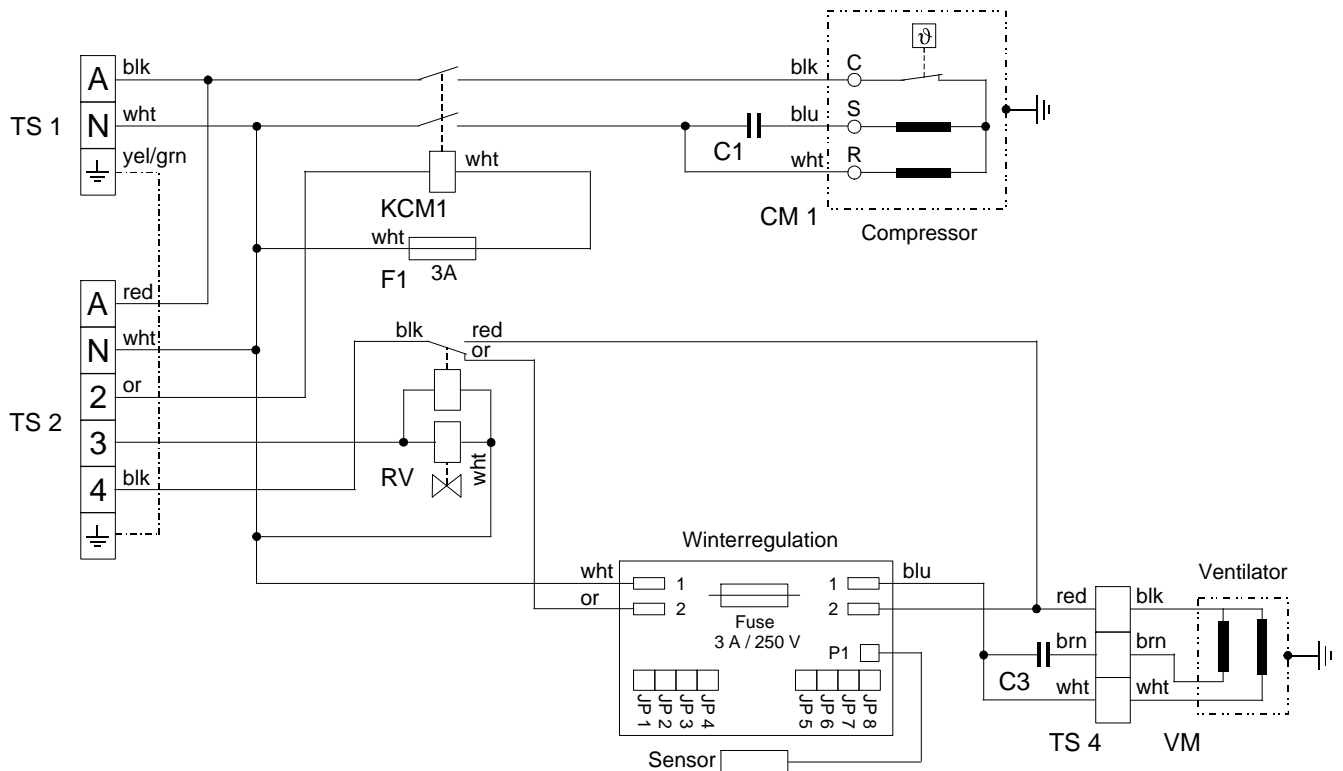

Legende:

TS1 = terminal strip (power supply)

TS2 = terminal strip (to indoor unit)

RV = reversal valve (only cooling / heating)

KCM1 = contactor

CM1 = motor (compressor)

VM = motor (ventilator)

C1 = capacitor (compressor)

C3 = capacitor (ventilator)

F1 = fuse (3 amp.)

We reserve the right to make changes to dimensions and design in the interest of technical progress.



Certification for

Date 01/2003

? Initial operation ? Subsequent operation of a REMKO air-conditioning system

Unit data	Outdoor part	Indoor unit
Type of unit	RKS	RKV
Unit number		
Refrigerant length/height of line	_____	m/ m
Oil elevation arcs	_____	units
Additional quantities	_____	g
Condensation pump	_____	

Operator / Assembly location	Name:
Street:	Postal code, city:
Telephone:	Fax:

Test of cold cycle		Result	
Visual check:	Assembly of outdoor part and indoor unit	<input checked="" type="checkbox"/> good	<input type="checkbox"/> poor
	Heat-exchanger, insulation, lines	<input checked="" type="checkbox"/> good	<input type="checkbox"/> poor
	Electrical fuse protection type A	<input checked="" type="checkbox"/> good	<input type="checkbox"/> poor
	Electrical power / control line Cu (mm ² / mm ²) /	<input checked="" type="checkbox"/> good	<input type="checkbox"/> poor
Impermeability check	Vacuum mbar	<input checked="" type="checkbox"/> good	<input type="checkbox"/> poor
	Excess pressure mbar	<input checked="" type="checkbox"/> good	<input type="checkbox"/> poor
Add. preparation:	Refrigerant refill amount g	<input checked="" type="checkbox"/> good	<input type="checkbox"/> poor
	Shut-off valves open	<input checked="" type="checkbox"/> good	<input type="checkbox"/> poor
Functional check:	Condensation flow, condensation pump(s)	<input checked="" type="checkbox"/> good	<input type="checkbox"/> poor
	Cooling mode	<input checked="" type="checkbox"/> good	<input type="checkbox"/> poor
Operational check:	Compressor mode	<input checked="" type="checkbox"/> good	<input type="checkbox"/> poor
	Ventilator mode	<input checked="" type="checkbox"/> good	<input type="checkbox"/> poor
Measurement tests:	Room temperature / Air outlet temperature °C / °C /	<input checked="" type="checkbox"/> good	<input type="checkbox"/> poor
	Suction temperature / Overheating °C / K /	<input checked="" type="checkbox"/> good	<input type="checkbox"/> poor

Comments:

- ? The room air conditioning system above was put into operation without any objections.
- ? The operator has been trained and the operating instructions distributed.
- ? The unit could not be put into operation for the reasons indicated above.

Executing company:

Company:	Stamp and signature
Street:	
Postal code, city:	
_____	Signature of person assembling and putting unit into operation

Date

Operator signature

REMKO GmbH & Co. KG

Klima- und Wärmetechnik

D-32791 Lage • Im Seelenkamp 12

D-32777 Lage • PO Box 1827

Phone +49 (5232) 606 - 0

Fax +49 (5232) 606260