

REMKO RKV 13 T / 24 T Wall/Ceiling Chests

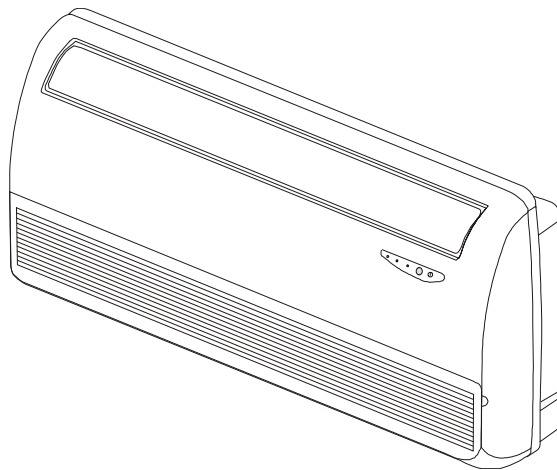

**Operation
Technology
Spare Parts**

Operating Instructions

Read these instructions carefully before setting up/operating the unit!

Our guarantee becomes null and void if the unit is used, set up or maintained improperly, or if modifications are made to the supplied unit without our prior consent.

Subject to alterations!

Wall/Ceiling Chests

REMKO RKV 13 T

REMKO RKV 24 T

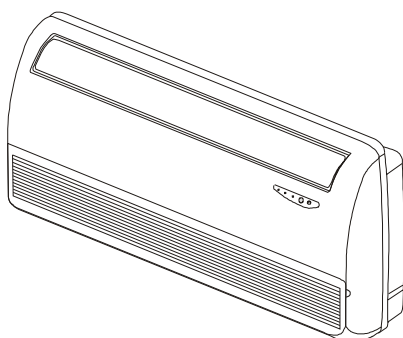

Contents	Page	Contents	Page
Safety Hints	4	Installation	12
Description of Device	4	Impermeability Check	13
Transport and Packaging	4	Electrical Connection	13
Operation	5	Condensation Connection	14
Shutting Down the Unit	8	External Condensation Pump	15
Maintenance	8	Prior to Initial Operation	16
Combinations	8	Initial Operation	17
Troubleshooting	9	Environment and Recycling	17
Technical Data	10	Customer Service and Guarantee	17
Dimensions	10	Certification of Initial Operation	18
Assembly Instructions for Service Personnel	11		

Always keep these operating instructions near or on the unit!

Safety Hints

Extensive tests have been conducted on the material, functionality and quality of these units before they were shipped. These units may only be used in accordance with their intended purpose. Hazards may arise if the units are used improperly.

- ◇ The indoor unit is not suitable for outside operation!
 - ◇ Make sure that personnel trained in the operation of the air conditioner check the unit for visible defects on the operating and safety mechanisms each time before putting it into operation!
 - ◇ Before performing any work on the unit, the power cord must be unplugged and the unit secured against being switched on by unauthorised persons!
 - ◇ Operate the units only when assembled and for their intended purpose.
 - ◇ Keep in mind that it is dangerous to remove covers protective grilles, etc., during operation; this can lead to uncontrolled operating situations!
 - ◇ Operate the units exclusively within the permissible operating ranges.
Surrounding temperatures.
 - ◇ Make sure that the unit is kept at a safe distance from flammable objects!
 - ◇ Do not install the inside unit close to heaters or behind curtains and drapes!
 - ◇ Ensure that the air intake and outlet openings are not blocked and always clear of foreign objects!
 - ◇ Do not place any objects on top of the units!
 - ◇ The unit part may only be connected to a correctly installed and grounded power supply.
 - ◇ Do not operate the units if the atmosphere is contaminated by oil, sulfur or salt.
 - ◇ Never operate or use the units in rooms susceptible to explosions.
 - ◇ The units are also not suitable for operation in rooms containing large amounts of dust or aggressive air.
 - ◇ Do not use flammable sprays such as hair spray or spray paint in the direct vicinity of the units.
 - ◇ Do not expose the unit to direct streams of water.
 - ◇ Protect the indoor unit and the remote control from moisture and direct sunlight.
 - ◇ Protect all electric cables and connection lines from being damaged, for example, by animals.
 - ◇ Protect the indoor unit and the remote control from direct and indirect sunlight.
 - ◇ Do not expose the remote control to strong vibrations.
 - ◇ Regularly check that condensation is not blocked from flowing out of the unit.
 - ◇ Never operate the units without the air filters.
- ◇ The unit is equipped with a safety mechanism which prevents the condenser from being damaged caused by the unit switching back on right away after it has been switched off. It is only possible to restart after 3 minutes.
 - ◇ Cleaning and minor maintenance work may only be performed by the operator or an authorised person designated by him in accordance with the instructions contained in the section "Maintenance".
 - ◇ Installation and repair work may only be performed by authorised personnel
 - ◇ All REMKO air conditioners are supplied with the environmentally-friendly refrigerant R 407C.

Description of Device

The room air-conditioners in the REMKO RKV 13 T / 24 T series are split-design, direct-condensing units that can be mounted on the wall or ceiling.

The way the air conditioning system works is quite simple:

Warmth is removed from the room to be cooled. The environmentally-friendly refrigerant R 407C transports this warmth just as it does for all other REMKO air-conditioning products.

The units' primary function is to air-condition rooms.

They also filter and dehumidify the air, thus creating a comfortable climate in the room. The units also have a pure ventilation and dehumidification mode.

All units operate fully-automatically and offer a range of other options thanks to their microprocessor control.

They are operated using the supplied infrared remote control.

If the infrared remote control is defective or the batteries are dead, the units can be started via an emergency switch on the indoor unit (also in manual operation).

Transport and Packaging

The unit is shipped in a stable transport box made of cardboard. Please examine the unit when it is delivered.

Make note of any damage or missing parts on the shipping bill and notify the shipping company and your contract partner.

We do not assume any liability for subsequent complaints.

Operation

Inserting the batteries into the remote control

Prior to initial operation, the batteries supplied with the unit (2 type AAA batteries) must be inserted into the remote control.

1. To do this, slide off the cover of the battery slot on the back of the remote control in the direction of the arrow.
2. Insert the batteries.
Make sure that the polarity is correct, use the labelling in the slot.
3. Close the battery slot again.

The remote control

Two to four seconds after the air-conditioning unit has been connected to the power supply you can begin operation. The room air-conditioner is operated by means of the infrared remote control.

Signals can only be transmitted properly at a maximum distance of approximately 7m. A beep indicates that a button has been pressed and the signal has been correctly received.

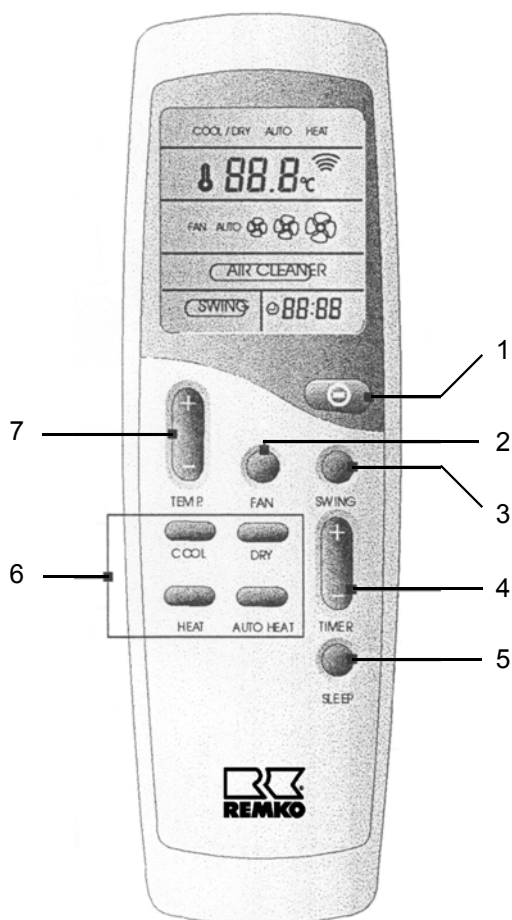

1 On / Off button

Press this button to put the unit into operation. The POWER display lights up.

2 Fan speed

Set the fan speed you want with this button. There are 4 speeds available: automatic, low, medium and high.

3 Swing button

When the unit is switched on (ON), the oscillating blade improves air distribution in the room.

4 Timer button

You can program the unit to automatically switch on or off within the next 24 hour-period with the timer.

5 Sleep button

If the Sleep function is activated, the set room temperature increases by 1°C after one hour. This function can be reset by pressing any button.

6 Mode buttons 1 to 4

The room air-conditioner has 4 modes:

1. Cooling mode:

In this mode, the warm air in the room is cooled to the desired temperature. The COMP. display begins blinking for approx. 3 minutes (mechanism which stops the unit from switching back to prevent damage to the compressor).

2. Dehumidification mode:

In this mode, the room is primarily dehumidified but the set temperature is maintained.

3. Heating mode:

This mode is not active for these models.

4. Auto Heat mode:

These models work exclusively in cooling mode when automatic operation is activated.

7 Temp. button

The Temperature button can be used to set the desired temperature in 0.5°C increments between 15°C and 30°C.

Manual operation

The unit can be put into operation manually, e.g. if the remote control is not operating properly or is lost. For manual operation, press the POWER button on the upper right of the receiver (control panel) of the indoor unit.

The following operating modes are then activated:

MODE: Automatic mode
TEMP : 24°C
FAN: Automatic
SWING: On
TIMER: Off

Button functionality

The following commands can be performed using the remote control at a distance of no more than 7m. Point the remote control at the receiver on the right side of the wall-mounted unit.

On / Off button

Activate and deactivate the indoor unit with the ON / OFF button . The following settings appear on display:



1. FAN AUTO = Fan speed
2. SWING = Oscillating blade
3. 25.0 °C = Set temperature
4. COOL = Mode

Fan button



When the FAN button  is pressed, 3 different-sized fan symbols or FAN AUTO are visible on the display. The size of the symbol represents the speed of the fan. Each time the button is pressed, the fan speed is reduced.

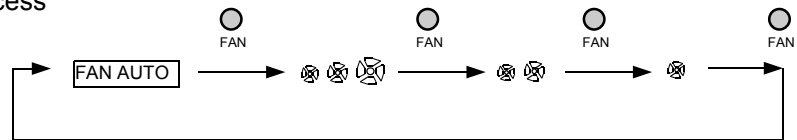

Functional process



Swing button

The SWING Taste  stops the oscillating blade. When switched on (display ) , the cooled air is distributed better in the room. The unit automatically distributes the air in a vertical direction only. The air can only be set to be distributed horizontally by manually adjusting the vertical plate fins.

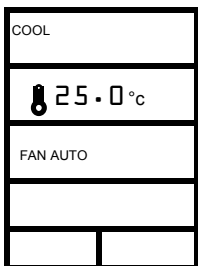

Functional process

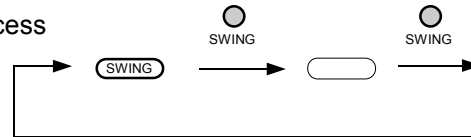

COOL mode

Use the COOL mode when you want to cool the room to the desired temperature. Reduce the desired temperature by pressing the Temperature button  in 0.5 °C increments. After you hear a beep, the COMP. display begins to blink for approximately 3 minutes. This waiting period is a forced pause to increase the service life of the compressor and the outdoor part. Once the display stops blinking, the air-conditioner begins working. If the temperature in the room falls 1 °C below the set temperature, the regulator switches cooling off.



Functional process

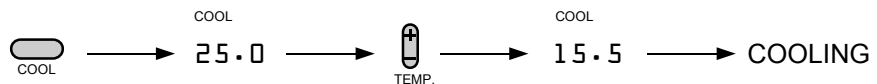

COOL / DRY mode

The COOL / DRY mode dehumidifies the room in an unregulated fashion. The temperature of the plate fin exchanger of the indoor unit almost always falls below the dew point of the air which causes the moisture in the air to condense on the plate fins. The dehumidification capacity is based on the moisture in the air and the room temperature. After the DRY button  has been pressed, the desired temperature can be selected and the unit begins working. The fan switches off at specific intervals to lower the plate fin temperature. You can exit this mode by switching to a different one.



Functional process

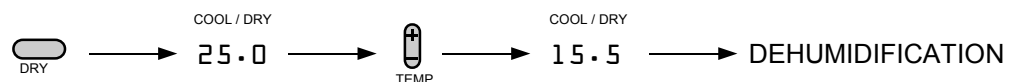

Sleep button

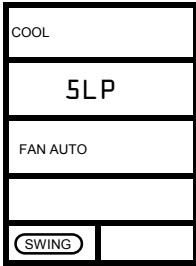

By pressing the SLEEP button, the room temperature increases by 1 °C one hour after the function has been activated. This function can be cancelled by pressing any button. The symbol 5LP disappears and the normal display appears.

Functional process



Timer button

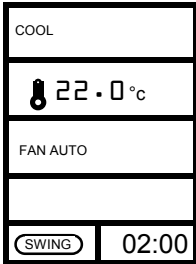

The TIMER button is used to program the unit to switch on or off at a later time. If the room air-conditioner is to be switched on at a later time, press the + or - button for approximately 2 seconds when the unit is off. If the room air-conditioner is to be switched off at a later time, press when of these buttons when the remote control is on. In both operating modes, 12:0H appears in the lower right-hand corner of the display. The desired length of time can be reduced or increased in 10 minute increments by pressing the - or + button. The change must be made within 3 seconds, otherwise the displayed length of time is saved.

When programming the unit to switch on with the timer function, the mode, the desired temperature and the fan speed of the last setting are transferred.

Once the settings have been saved, a clock appears on the display and "H" disappears. The colon begins to blink and the time counts backwards. Once the time has elapsed, the unit switches on or off automatically.

Position the remote control in such a way that communication with the air-conditioner is assured. The next time the timer is programmed, the last programmed time is called up.

Functional process

Delayed start

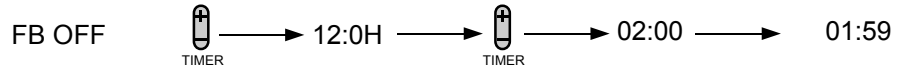

Delayed stop

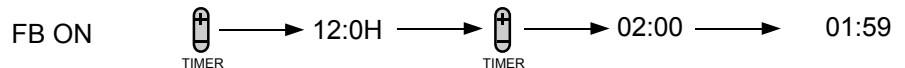

HEAT mode



This mode is not active for these models.

AUTO mode

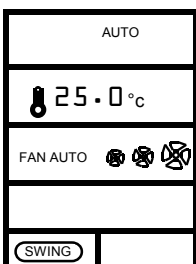

These models work exclusively in cooling mode when automatic operation is activated.

Shutting Down the Unit

Temporary shutdown

1. Switch all indoor units off using the remote control.
2. Disconnect the system with the main switch or fuse protection from the power supply.
3. Check the indoor unit and outdoor part for visible damage.
4. Clean the indoor unit and outdoor parts as described in the "Maintenance and Service" section. Cover the outdoor part if possible with a plastic cover to protect it from weather conditions such as snow.

Permanent shutdown

For environmental safety reasons, the air conditioners may only be deinstalled by authorised service centres. REMKO GmbH & Co. KG or your contract partner would be happy to provide you with the name of a service centre in your area.

Maintenance

Regular care and the observation of a number of basic rules will ensure the units' long service life and reliable operation.

Before any work on the units is performed, they must be disconnected from the power supply and prevented from being inadvertently switched on!

- ◇ Keep the units free of dirt, plants and other deposits and only clean the units with a damp cloth (do not expose them to a direct stream of water).
- ◇ If the units are extremely dirty, only use suitable cleaning materials.
- ◇ Do not use an abrasive cleaning agent or one that contains solvent.
- ◇ Before and after the operating season, check whether the diameter of the condensation lines has become smaller as a result of dirt. If so, they must be cleaned.
- ◇ Clean the air filters of the indoor unit at regular intervals, more often if necessary, in line with the operating instructions.

Never operate the units without the original filters otherwise the heat-exchanger fins would become dirty and the performance of the units would suffer. Dirty fins are difficult to clean.

Cleaning the filters

Clean both air intake filters on the right and left at intervals of no longer than two weeks. If the air is extremely dirty, shorten this timeframe accordingly.

Proceed as follows for cleaning:

1. Open the front of the unit by pushing the grille up and locking it into place.
2. You can now lift the filters up slightly and then pull them out.
3. Clean the filters using a standard vacuum cleaner.
4. Extreme dirt can be carefully removed with lukewarm water. Then the filters must air dry.
5. Insert the cleaned filters carefully. Make sure that they are in the right place (left/right).
6. Closed the front of the unit.

Combinations

RKV	13 W	24 W	13 C	24 C	13 T	24 T
RKS 513						
RKS 524						

	RKV 13 W	RKV 13 C	RKV 13 T
RKM 612			
RKM 712			
	RKV 24 W	RKV 13 C	RKV 24 T
RKM 618			
RKM 718			

Troubleshooting

This unit has been designed based on state-of-the-art manufacturing methods and it has been tested repeatedly to ensure that it is working properly. However, should problems occur, refer to the following list.

Before any work on the units is performed, they must be disconnected from the power supply (fuse or repair switch) and prevented from being inadvertently switched on!

Problem	Possible cause	Check	Remedy
The unit does not start or it switches itself off automatically.	Power failure, power too low	Are all other electrical components working?	Check current and wait for the device to start again
	Power fuse / power supply defective	Are all currents for lighting functional?	Replace power fuse / Switch on main switch
	Power supply line damaged	Are all other electrical components working?	Maintenance by authorised personnel
	Amount of time waited after switching unit on was too short	Plan for longer waiting periods	Restart after approximately 5 min.
	Operating temperature too low / too high	Are the fans still working?	Observed temperature range between 15 and 30 °C
The indoor unit is not responding to the remote control.	Timer set to "ON"	Is the timer set?	Delete programming and restart
	Excess current caused by thunderstorms	Was there recently lightning in the region ?	Switch the system off and then back on again
	Polarity of batteries incorrect after replacement	Is the polarity incorrect?	Insert batteries with the correct polarity
	Transmission distance too great / reception blocked	Is the transmission signal at a distance of approx. 3 m when the button is pressed?	Reduce distance to under 6 m and change location
	Remote control defective	Does the unit work in manual mode?	Replace remote control
	Too much direct sunlight on the receiver or transmitter	Does the function work in the shade?	Place the transmitter or receiver in the shade
	Electromagnetic fields are disrupting transmission	Does the unit work after potential causes of disruption have been eliminated?	No signal transmission when sources of disruption are operated simultaneously
	Remote control buttons stuck / two buttons pressed at once	Does the symbol  appear on the display?	Unstick button / only press one button
	Dead batteries in the remote control	Are the batteries new? Is the display incomplete?	Insert new batteries
Temperature setting too high	Is the selected temperature above the room temperature?	Reduce selected temperature	
The unit is operating at a low cooling capacity.	Filter is dirty/ intake / outlet opening is blocked by foreign bodies	Have the filters been cleaned?	Clean filters
	Windows and doors are opened / increased amount of warm air or cold air	Have there been changes in design or use?	Close the windows and doors / mount additional systems
	Cool mode is not set	Does the Cool symbol (COOL) appear on the display?	Correct the unit settings
Condensation water is leaking from the indoor unit.	The drainage line of the condensation collector is blocked / damaged	Can condensation drain freely?	Clean the drainage line and the condensation collector
	External condensation pump or float regulator is defective	Is the collector filled with water and the pump is not working?	Have pump checked by authorised service centre

Should the unit still not work after performing these functional checks, please contact the closest dealer or REMKO GmbH & Co KG. directly. See also section "Customer Service and Guarantee".

Technical Data

Model		RKV 13 T	RKV 24 T
Cooling capacity ¹⁾	W	See corresponding outdoor part	
Refrigerant		R 407C	
Operating range	°C	+15 °C to + 30 °C in 0.5 °C - steps	
Connection pressure line RKS	inch (mm)	3/8 (9.52)	
Connection intake line RKS	Inch (mm)	1/2 (12.7)	5/8 (15.9)
Connection pressure line RKM	Inch (mm)	1/4 (6.35)	
Connection intake line RKM	Inch (mm)	1/2 (12.7)	
Additional amount to add ²⁾	g/m	18 / 15	
Dehumidification capacity	l/h	1.0	2.0
Power supply	V / Hz	230/1~ 50 Hz supplied via outdoor part	
Power consumption	W	65	80
Current consumption	A	0.3	0.4
Fan capacity	W	50	65
Fans speeds		3 plus automatic	
max. amount of air	m³/h	500 / 570 / 680	820 / 950 / 1020
Dimensions height / width / depth	mm	550 / 1120 / 215	550 / 1120 / 215
Weight unit	kg	22	23
VPE	kg	24	25
Sound pressure level ³⁾	dB(A)	40 / 43 / 51	42 / 45 / 52
Infrared remote control		Series	
Colour		White	
Ref. no.		1613503	1613504
Condensation pump (accessory)	Ref. no.	1613167	

1) Capacities based on ISO R 859A; room temperature of TK 27°C/FK 19°C - outside temperature 35°C

2) For connection lines of 5 m or longer

3) Noise measurement DIN 45635 - 01 - KL3

Dimensions

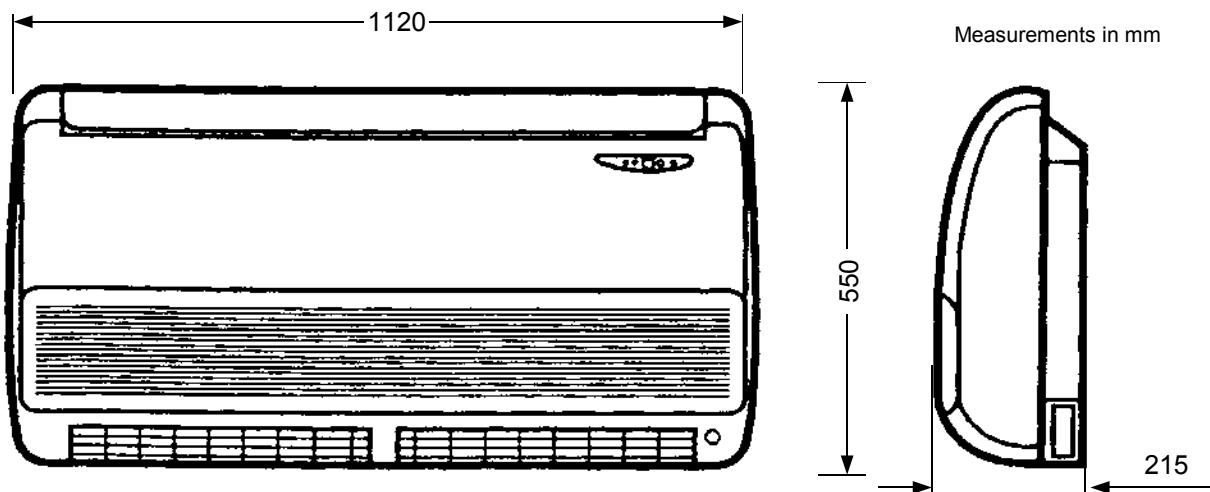

Assembly Instructions for Service Personnel

Important instructions prior to installation

- ◇ Ensure that the contents of the package are complete and that the units have no visible damage resulting from transport. Any problems must be communicated directly to your contract partner and the shipping company.
- ◇ Place the unit in its original packaging as close as possible to the location where it will be assembled.
- ◇ Select a location to set up the unit where air can flow freely in and out of the device.
- ◇ Minimum distances are 500 mm on the top and 150 mm on the bottom.
- ◇ Plan how to lay the condensation line. It must be placed at an incline of at least 2 % if placed horizontally.
- ◇ Prior to insulation, check that the electrical connection values and the data on the type plate are consistent.
- ◇ Only remove the protective caps of the unit connections just before connecting the refrigerant lines.
- ◇ Keep in mind that the power supply is only connected to the outdoor part.
- ◇ The control lines to the indoor unit should be placed together with the refrigerant lines.
- ◇ Make sure that all electrical connections meet the DIN-VDE requirements.

Common installation mistakes

When performing the installation, make sure to observe the following:

- ◇ Do not install the unit in the direct vicinity of objects that emit intense heat (e.g. lights).
- ◇ The air intake and outlet openings may not be blocked by furniture, curtains, etc.
- ◇ Make sure that the electrical terminals have been properly attached.
- ◇ The refrigerant lines may not be bent or pressed. Protect open refrigerant lines from moisture with suitable caps or tape.
- ◇ Make sure that all refrigerant lines including all connectors and valves are insulated against heat.
- ◇ Prevent unnecessary bends to minimise the pressure loss in the refrigerant lines and ensure that the compressor oil can recirculate properly.
- ◇ The condensation line must be placed at an incline of at least 2 %.
- ◇ If this line is connected to the drainage line, an odour seal must be installed the upper edge of which may not extend beyond the lower edge of the indoor unit.

Wall lead-throughs

Wall lead-throughs are necessary to establish the connection between the indoor unit and the outdoor part. Please observe the following:

- ◇ For the connection lines to the outdoor part, a hole at least 70 mm in diameter must be created.
- ◇ The hole must be placed at an incline of at least 10 mm or 2% from the inside to the outside.

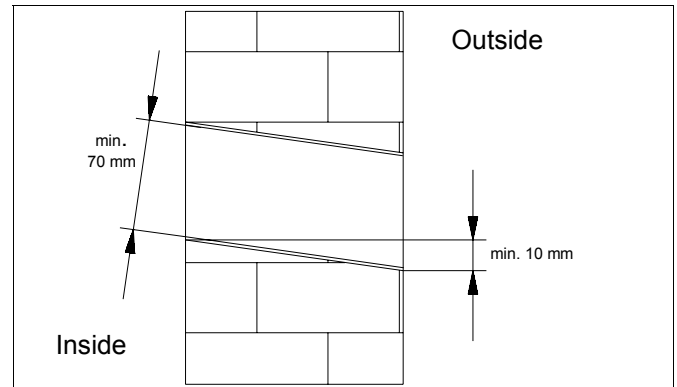

- ◇ Before beginning work, make sure that there are no supply lines (water, etc.) located in the vicinity of the wall lead-through.
- ◇ We recommend cushioning the inside of the hole or lining it with a PVC pipe to prevent the lines from being damaged.

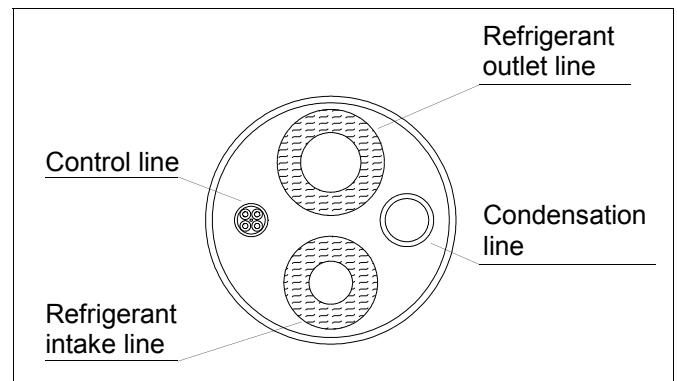

Wall lead-through diagram

- ◇ After assembly is complete, the wall lead-through must be sealed with a suitable sealing compound. Do not use any materials containing cement or lime!

Installation

Assemble the indoor unit in such a way that condensation drainage is not blocked and air can always flow freely in and out of the unit!

Assembling the wall mount

The indoor unit is attached with a wall mount.

Prior to attachment, take a look at the 3 connection options for the refrigerant, condensation and control lines to the indoor unit:

1= back, 2 = right, 3 = underneath.

The openings are closed by panels that have to be broken depending on the selected connection option.

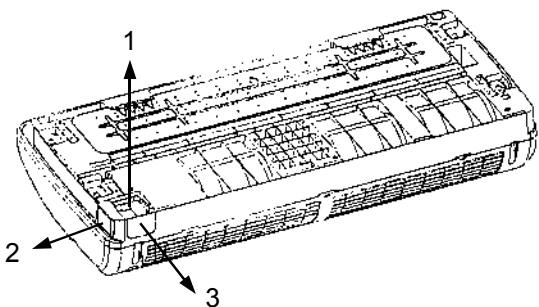

The wall mount is attached with screws (supplied) and dowels suitable for attachment as shown below (rear view, all measurements in mm).

Make sure that the unit is placed horizontally and maintain the required safety distances!

Wall mount

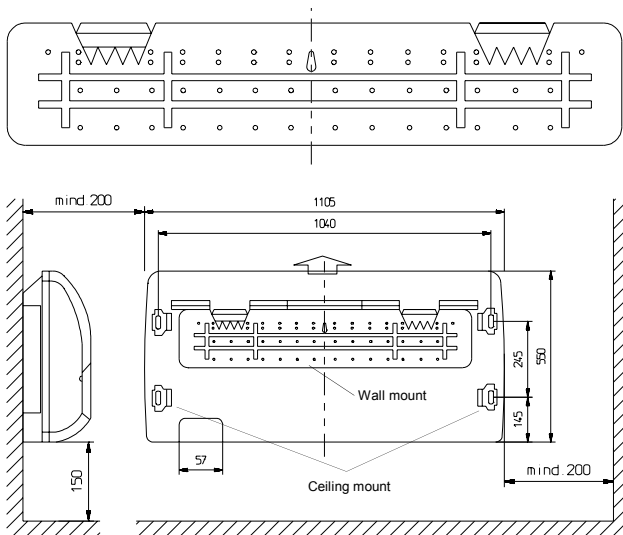

Assembly distances (side view/rear view)

Attachment to the wall mount

After the wall mount has been assembled, the indoor unit is inserted from above until it locks into place.

◇ Make sure that it is securely placed!

Ceiling assembly

When assembly the unit on the ceiling, the 4 integrated ceiling mounts must be used. These are used to attach the indoor unit by means of suitable dowels 8 mm \varnothing ; screws / bolts as well as washers to the ceiling.

◇ An incline of approx. 8 mm to the connection adaptor must be maintained to ensure that the condensation can flow freely!

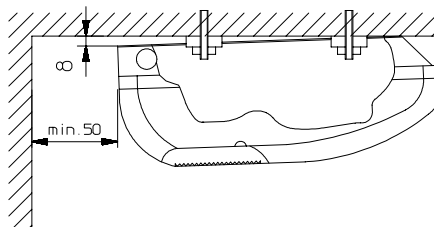

Make sure that the unit is securely placed and maintain the required minimum safety distances!

Refrigerant lines

1. Select an assembly location that guarantees free access to the back of the unit.
2. The required line cross-sections are provided in the "Technical Data" section. When assembling the unit, observe the bending radii of the refrigerant lines and never bend the hose in the same place twice. This may cause the line to become brittle or crack.
3. Decide on a drainage option and cut the refrigerant connection line hose accordingly.
4. Use only the tools below for assembly.

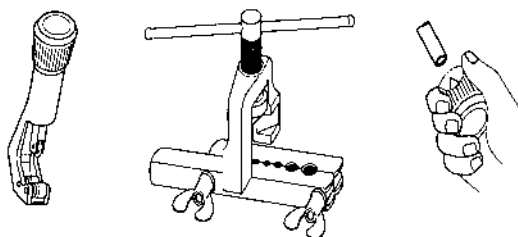

Only tools approved for use in cold conditions may be used.

5. Remove the swivel nuts of the units and use these for further assembly.
6. Work with the refrigerant lines as shown in the figure below.

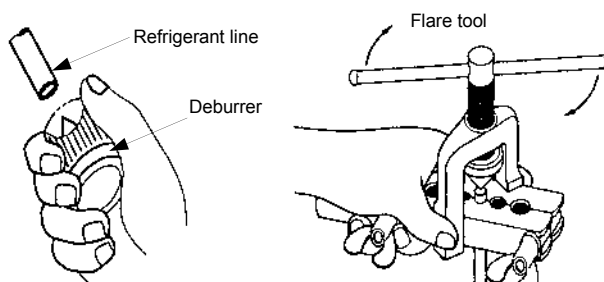

- Before you flare the refrigerant lines, ensure that there is a swivel nut on the hose. Also make sure that the flare has the correct shape.

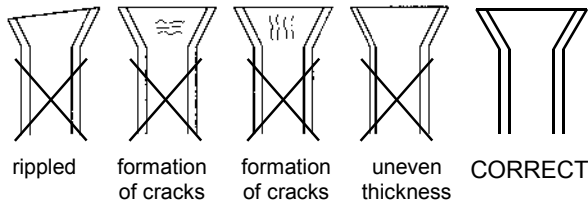

- The condensation and control lines also have to be connected and, depending on the selected option, guided to the outside.
Described below.
- If, due to structural design conditions, it is not possible to guide the condensation line through as well, make sure that the condensation can drain freely at all times.
- Hang the indoor unit leaning slightly to the back in the previously assembled wall mount and press the bottom of the unit into the mount until it catches.

- If the outdoor part is set up at a higher level than the indoor unit, appropriate steps must be taken for oil recirculation.
This can be achieved by installing oil elevation arcs every 2.5 meters of line going up.

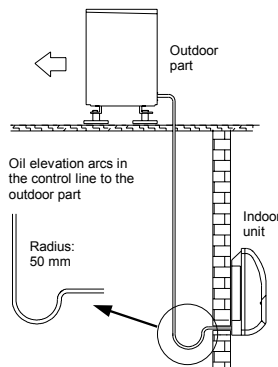

- First manually connect the refrigerant lines with the screws of the indoor unit to ensure that they are in the proper position. Now tighten the bolts using 2 hexagonal wrenches that have a large enough opening.
- The installed refrigerant lines are heat-insulated and sealed against diffusion. Only use insulated hoses suitable for this temperature range.
- Lay the connected lines and the control lines to the outdoor part. Remove the protective caps of the valves and proceed as described under Point 5.

Impermeability Check

Once all connections have been made, the manometer station is connected to the corresponding valve connections as described below:

red = small valve = injection pressure.
blue = large valve = suction pressure.

After the connection has been made, an impermeability test is conducted using dry nitrogen.

The connections that have been established are sprayed with a leak locator spray to test for impermeability. Tighten the bolts more firmly or, if necessary, create a new flare.

After this test has been successfully conducted, any excess pressure is removed from the refrigerant lines and a vacuum pump with an absolute final partial pressure of at least 0.01 mbar is put into operation to create a vacuum in the lines. This also removes any moisture from the lines.

A vacuum with a minimum of 0.05 mbar must be created!

How long it takes to create the vacuum is based on the hose line volume of the indoor unit and the length of the refrigerant lines. However, this process takes a minimum of 30 minutes.

Once foreign gases and moisture have been completely removed from the system, the manometer station valves are closed and the valves of the outdoor part are opened as described in the section "Initial Operation".

Electrical Connection

To control the outdoor part, a 4-wire control line must be laid to the indoor unit and a feed-in line installed. The electrical installations may only be performed by authorised personnel in line with the relevant regulations. Local guidelines for operation as well as the requirements established by local energy supply companies must be observed for setup and initial operation.

Prior to performing any work on the indoor unit and outdoor part, it must be unplugged from the power supply and secured against being inadvertently switched on!

Prior to beginning installation, please observe the following:

- ◇ We recommend that the customer install a main or repair switch close to the outdoor part.
- ◇ Power is supplied to the indoor units via a connection line from the outdoor part.
- ◇ Fuse protection for the system must occur in accordance with the technical data.

The connections of the indoor unit are located on the right hand side next to the fan and are hidden from view by the housing. Proceed as follows to connect the line:

- Open the air intake grille of the unit downwards or take it off completely and remove the right air filter.
- The connection terminal strip is freely accessible once the protective cover has been removed.
- Connect the indoor unit to the outdoor part using the current-free line in accordance with the electrical wiring diagram and reassemble the unit in the reverse order.

Electrical wiring diagram

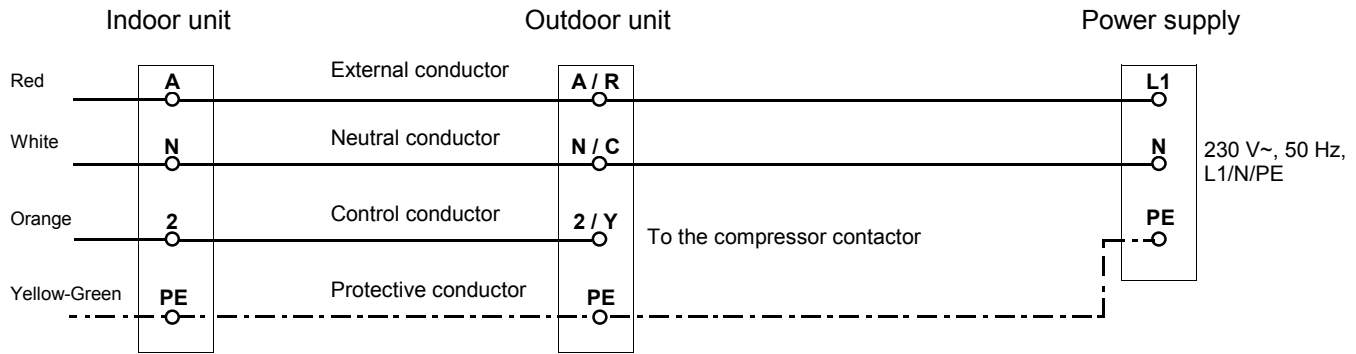

Connections to the outdoor units RKS and RKM

The connection terminals of the outdoor units can have different labels depending on the type of unit:

Indoor unit	Description	RKS	RKM
L1	External conductor	A	R
N	Neutral conductor	N	C
L	Control contactor condenser contactor	2	Y
PE	Protective conductor	⏏	⏏

Condensation Connection

Condensation forms on the evaporator during cooling operation because temperatures below the dew point are reached. The collection tray of the indoor unit is equipped with a condensation hose. This must be placed at an incline to ensure that the condensation drains.

General information

- ◇ The condensation drainage line is generally placed in the same guideway as the refrigerant lines.
- ◇ If, as a result of structural design conditions, it is necessary to have a different guideway for the condensation hose, the hose can also be guided to the indoor unit through a different drain.
- ◇ If the condensation is being guided to a drainage line, please install a siphon-like hose guideway which acts as an odour seal.
- ◇ Make sure there is an adequate incline for drainage (at least 2 %).
- ◇ If the unit is being operated at outside temperatures below 0°C, the lines must be placed in such a way that they are protected from frost.

Ceiling assembly:

The condensation hose is guided out through an additional, breakable oval housing opening close to the grille

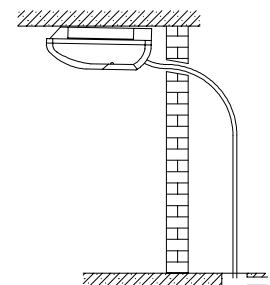

Wall assembly:

The condensation hose is guided out below or behind the indoor unit

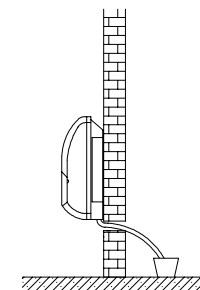

The supplied condensation hose can be extended with standard hoses that are 17 mm in diameter. Always use suitable hose clips.

After the hose has been laid, check to make sure that condensation can drain freely.

External Condensation Pump

The condensation pump which can be purchased as an accessory (Ref. no. 1613167) transfers the condensation which accumulates in the indoor unit to drains that are placed in inconvenient locations, even if the drain is located above the unit. The pump can be installed inside the unit.

Follow the operating instructions for the pump as well as the instructions below:

- ◇ Protect the housing from coming into direct contact with the condensation.
- ◇ Never open the housing of the pump.
- ◇ Check the operating current of the pump and the power supply for consistency.
- ◇ Use the alarm contact to switch off the outdoor part.
- ◇ Keep in mind that you should only use the alarm contact together with a contactor or relay to switch off the outdoor part, depending on the load.
- ◇ Connect the pump securely to the control line.

The condensation pump consists of 2 components:

- ◇ The reservoir with sensor
- ◇ The pump

Reservoir with sensor

The reservoir collects the condensation. A sensor switches the pump on when a specific water level has been reached.

The electronic sensor allows the reservoir to be rotated by up to 30° on its axis.

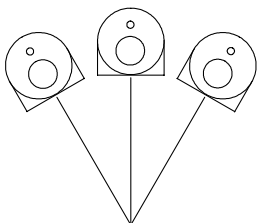

Possible assembly positions:
Rotation of the axis up to 30°
to the right and left.

Pump

The pump is attached to the right side of the unit (seen from the back) using the supplied, self-adhesive strips.

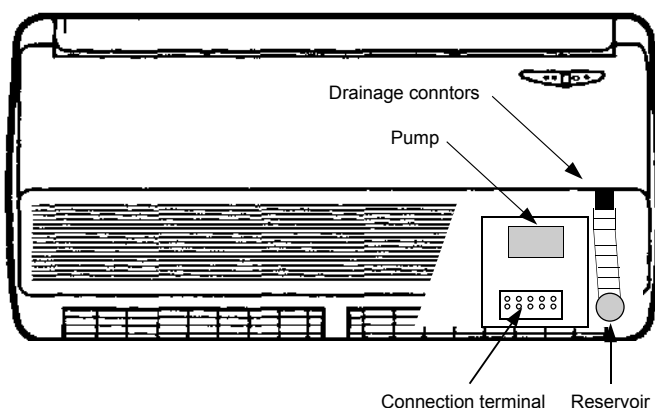

Electrical connection of the condensation pump

The electrical connections may only be made by authorised service personnel in accordance with the relevant regulations.

Prior to performing any work on the unit, it must be unplugged from the power supply and secured against being inadvertently switched on!

There is an electrical connection area located under the hose connections. This area also a cover that can be taken on and off.

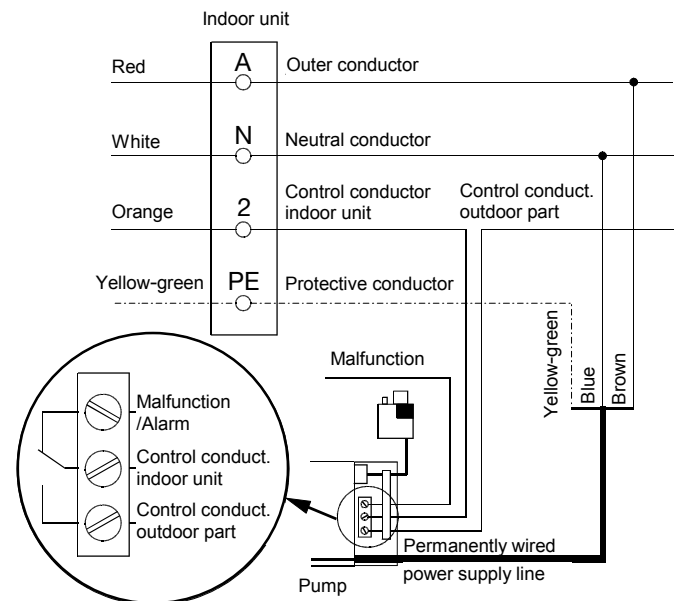

The pump is equipped with an alarm contact that switches off the indoor unit and can also control a customer-installed malfunction/alarm system.

Connections of the condensation pump on the water side

The reservoir is attached to the condensation collection tray connection of the indoor unit via a customer-supplied hose (20 mm Ø). The factory-installed flexible hose of the condensation tray must be disassembled.

The reservoir and pump are connected to one another with the long suction hose and the pluggable sensor line from the reservoir. To ensure that the pump operates as quietly as possible, the suction hose should not be shortened.

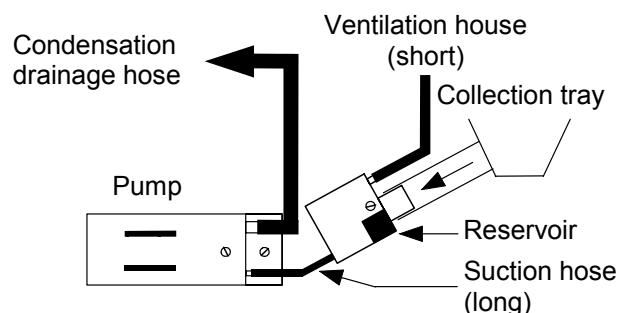

The supplied ventilation hose must be used for the reservoir to function properly. The end of the ventilation hose must at least be at the same height as the condensation tray to prevent water from overflowing.

The supplied metal wire clips are used to secure the hose in a vertical position. Keep the hose from being suspended which will prevent an air pocket from forming.

The 6 mm (inner diameter) thick hose is placed at a maximum height difference of 6 meters to the drain. The condensation line should be as vertical as possible to guide the condensation.

If the pump is installed outside the unit, a maximum height difference of 3 m between the lower edge of the unit and the pump mounted above may not be exceeded.

Initial operation of the condensation pump

Before putting the pump into operation, the lines that have been laid must be checked to ensure that they are functioning properly and leakproof.

1. Switch the power supply of the pump on.
2. Pour distilled water into the condensation tray until the pump switches on from the reservoir.
3. Pump operation can be heard when it is being operated for the first time or being put back into operation.
After it has run for short period, the noise normalises.
4. Keep in mind that the pump automatically switches off once the water has been pumped out of the reservoir.
5. If, upon initial operation, there is a lot of noise from vibrating hoses, insulate these hoses using foam hoses.
Condensation buildup is prevented when using insulated hoses sealed against diffusion.
6. Check the function of the alarm contact by drastically increasing the amount of water.
The alarm contact should switch off the unit.

Prior to Initial Operation

After the pressure has been tested, the vacuum pump must be connected to the valve connections of the outdoor part (see section "Impermeability Check") by means of the manometer station and a vacuum created.

Prior to initial operation of the unit and after the cold cycle has been serviced, the following checks must be performed:

- ◇ Check all refrigerant lines and valves for leaks with a leak locator spray or soapy water.
- ◇ Check that the connection lines did not get switched by mistake (especially for the RKM series 600 and 700).
- ◇ Check the refrigerant lines and the insulation for damage.
- ◇ Check that the electrical connection between the indoor unit and the outdoor part has the correct polarity.
- ◇ Check all fixtures and suspended parts to ensure that they are in the proper position and at the correct height.
- ◇ If the refrigerant line is longer than 5 m, more refrigerant should be added to the system.

Adding refrigerant

The additional refrigerant amount required is based on the length and the diameter of the pressure line.

Length of line	Hose diameter	Additional quantity per m
Up to and including 5 m	-	-
5 m up to and including a max. of 15 m	6.35 mm Ø / 1/4"	15 g/m
	9.52 mm Ø / 3/8"	18 g/m

Procedure:

1. Remove the vacuum pump and connect the filling cylinder.
2. Place the open cylinder on a scale and calibrate the scale to zero.
3. Create a vacuum in the hose at the height of the manometer distribution pipe.
4. Determine the required amount based on the information in the table above and open the suction pressure side of the manometer to begin the filling process.
5. Close the manometer valve when the appropriate amount has been added.

Initial Operation

The unit may only be put into operation by the manufacturer or an authorised representative. Initial operation must be performed using the certification of initial operation (page 18) and documented!

To ensure that the unit is functioning properly, a functional check must be performed to identify any irregularities during unit operation.

Prior to the test run, all shut-off mechanisms located in the old cycle must be opened (see the assembly instructions for the outdoor part)

Test run

Conduct the test run in the following order:

1. Switch the customer-installed main switch or fuse on.
2. Adjust the target temperature on the indoor unit to a lower value than the existing room temperature using the remote control.
3. Switch the unit to cooling mode with the  button.

The compressor starts a couple of minutes later due to the delayed start.

Test run procedure

Proceed as follows during the test run:

1. Check that the fan and cooling mechanisms are running smoothly.
2. Check that cold air is being expelled from the indoor unit and warm air from the outdoor part.
3. Measure the surface temperature of the heat-exchanger, make a note of it in the initial operation log. When measuring, hold the thermometer on the connector of the thin refrigerant line.
4. During the test run, check all regulating, control and safety mechanisms to ensure that they are functioning and set properly.
5. Check the indoor unit's control mechanisms using the functions described in section 4.2 "The remote control". (timer, temperature settings, fan mode and dehumidifying mode).
6. Adjust the plate fins correctly to prevent air from being distributed unfavourably.
7. Familiarise the operator with the system and give him the certificate for initial operation

Environment and Recycling



Important information about recycling!

Only authorised personnel may come into contact with the cold cycle. This ensures that refrigerant does not escape into the environment when the unit is being repaired. Both the refrigerant and the system parts are subject to special requirements for disposal.

The refrigerant in use is a safety refrigerant. This means that, should damage occur, the quantities released will not cause injury to the respiratory systems of people and animals.

Do not touch the liquid refrigerant as it can freeze the skin!

Customer Service and Guarantee

For the guarantee to be valid, the purchaser or his customer must completely fill out the "guarantee certificate" enclosed with all units and send it back to REMKO GmbH & Co. KG.

The units are repeatedly tested at the production site to ensure that they are working properly. If a malfunction occurs that cannot be eliminated by the operating personnel, please contact your dealer or contact person.

Operation/handling which does not comply with these instructions is prohibited!

In cases of non-compliance, we assume no liability and the guarantee becomes null and void.

Proper use

The indoor units have been designed and fitted exclusively for operation with REMKO outdoor parts belonging to the RKV and RKM series.

The manufacturer assumes no liability for damage resulting from non-compliance with manufacturer specifications and legal requirements, or if modifications are made to the units.



Certification for

- Initial operation** **Subsequent operation**

of a REMKO air-conditioning unit / system

Unit data according to type plate

	Outdoor part	Indoor unit 1	Indoor unit 2	Indoor unit 3
Unit type:				
Unit number:				
Setup location:				

Set up by:

Name:
Street:
Postal code, city:

The following must be performed / measured / validated during initial operation:

Test	Result	
Visible check setup / assembly of outdoor part and indoor unit(s)	<input type="checkbox"/> OK	<input type="checkbox"/> problem
Visible check of the heat-exchanger	<input type="checkbox"/> OK	<input type="checkbox"/> problem
Visible check of the connection lines (switched, damaged, bent?)	<input type="checkbox"/> OK	<input type="checkbox"/> problem
Visible check of the heat insulation (condensation)	<input type="checkbox"/> OK	<input type="checkbox"/> problem
Check of the condensation drainage (with water) incl. condensation pump (if applicable)	<input type="checkbox"/> OK	<input type="checkbox"/> problem
Impermeability check of the connections on the outdoor part and indoor unit(s)	<input type="checkbox"/> OK	<input type="checkbox"/> problem
Shut-off valves on the outdoor unit open (if applicable)	<input type="checkbox"/> OK	<input type="checkbox"/> problem
Test run of unit operation		
Compressor / fan [outdoor part and indoor unit(s)]	<input type="checkbox"/> OK	<input type="checkbox"/> problem
Power consumption		A
Room temperature / air outlet temperature / air intake temperature	°C /	°C / °C
Functional test of remote control	<input type="checkbox"/> OK	<input type="checkbox"/> problem
Comments:		

- The room air conditioning system above was put into operation without any objections.
- The operator has been trained and the operating instructions distributed.
- The unit could not be put into operation due to the reasons above.

Executing company:

Company:
Street:
Postal code, city:

_____ Date

_____ Signature of person assembling / putting unit into operation

_____ Operator signature

REMKO GmbH & Co. KG

Klima- und Wärmetechnik

D-32791 Lage · Im Seelenkamp 12

D-32777 Lage · PO Box 1827

Phone +49 (5232) 606 - 0

Fax +49 (5232) 606260

E-Mail: info@remko.de

Internet: www.remko.de