

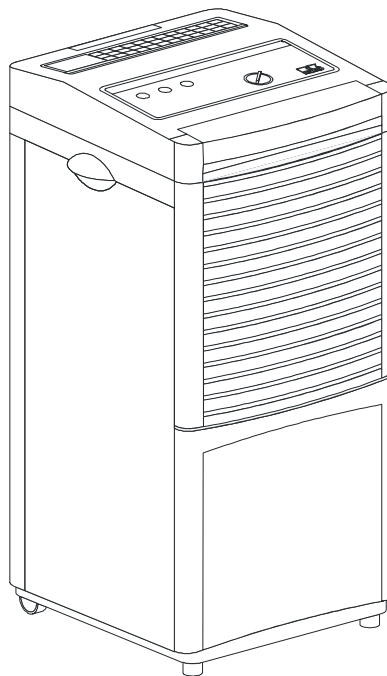

# **REMKO ETF 100 - 150 Mobile Dehumidifier**



**Operation  
Technology  
Spare Parts**



# Operating Instructions

Make sure to read these instructions carefully before starting/using the unit!

Our guarantee will become void when the unit supplied by us is used and installed for inadequate purposes, or maintained incorrectly, etc., or if it is changed without our prior consent.

Subject to alterations!

## Mobile Dehumidifier REMKO ETF 100 - 150

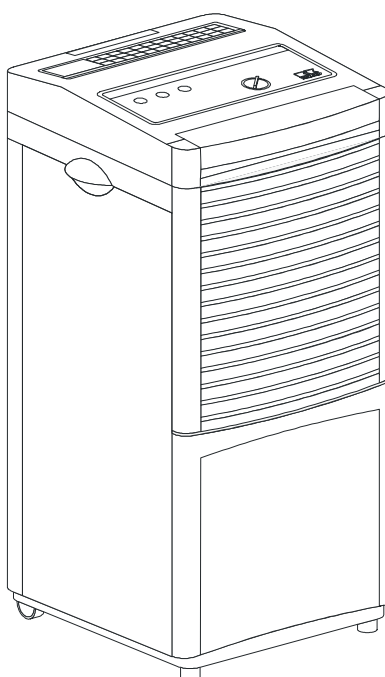

CE

<b>Contents</b>	page	<b>Contents</b>	page
Air Dehumidification	4	Maintenance and Service	11
Safety Instructions	6	Exploded View	12
Unit Description	7	Spare Part List	13
Installation	8	In Case of Troubles	14
Starting	8	Technical Data	14
Discard the Unit	10	Wiring Diagram	14
Transport Instructions	10	Maintenance and Service Log	15
Cleaning the Filter	11		



Always keep these operating instructions near or on the unit!



# Air Dehumidification

The processes that take place during air dehumidification are based on physical laws. We will try to describe these in a simplified form to give you a rough idea about the principle of air dehumidification.



## The Use of REMKO Air Dehumidifiers

- ◇ No matter how well doors and windows are insulated, wetness and humidity penetrate even through thick concrete walls.
- ◇ The water quantities required for binding regarding the production of concrete, mortar, plaster, etc. need in some cases 1 or 2 months to diffuse.
- ◇ And even the humidity that penetrates into the brickwork after floods and inundations is released very slowly.
- ◇ E.g. this is also the case regarding humidity contained in stocked materials.

The humidity that emanates from parts of buildings or materials (water vapour) is absorbed by the ambient air. Consequently the humidity content of the air increases which results in corrosion and in the formation of mildew, decay, flaked off paint coats and other undesired damage caused by humidity.

E.g. the following diagram shows in an exemplary way the corrosion speed of metal at different air humidity rates.

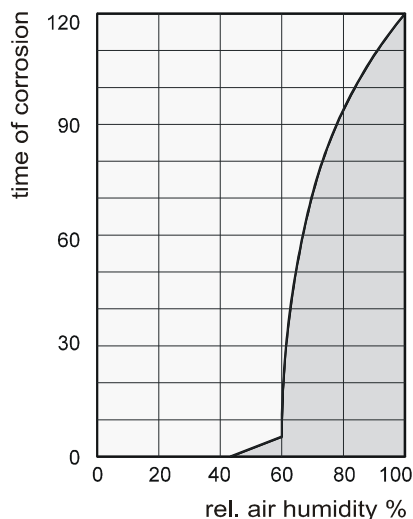

As you can see the corrosion speed is insignificant at a relative air humidity of less than 50 % and at a humidity rate of less than 40 % it can even be neglected. When the relative humidity exceeds 60 % corrosion speed increases considerably.

This limit regarding damages caused by humidity is also applicable to many other materials, such as powdery substances, packing materials, wood, and electronic apparatuses.

There are two different ways of drying the buildings:

### 1. By heating and exchanging the air:

The ambient air is heated to absorb humidity and to be carried off to the outside. However, the total generated energy is lost with the carried off humid air.

### 2. By dehumidifying:

The humid air in the closed room is continuously dehumidified according to the condensation principle.

Dehumidification has a decisive advantage regarding energy consumption:

Energy is exclusively needed for the existing room volume. The mechanical heat released during the dehumidification process increases the room temperature slightly.

*When used correctly the air dehumidifier consumes only approx. 25 % of the energy to be supplied according to the "heating and ventilation" principle.*

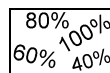

## Relative Air Humidity

Ambient air is a gas mixture and it always contains a certain rate of water in the form of water vapour.

This percentage of water is indicated in g per kg of dry air (absolute water content).

1 m<sup>3</sup> of air weighs approx. 1.2 kg at 20° C.

Depending on the temperature each kg of air can only absorb a defined quantity of water vapour. When this quantity has been absorbed, the air is "saturated" and has a relative humidity of 100 %.

*By relative air humidity we understand the relation between the percentage of water vapour contained in the air at the moment concerned and the maximum possible percentage of the water vapour, based on equal temperatures.*

The capacity of air to absorb water vapour increases with raising temperatures. This means that the maximum possible (= absolute) water content is increased with increasing temperatures.

Temp. °C	Water vapour content in g/m <sup>3</sup> at an air humidity of			
	40%	60%	80%	100%
-5	1,3	1,9	2,6	3,3
+10	3,8	5,6	7,5	9,4
+15	5,1	7,7	10,2	12,8
+20	6,9	10,4	13,8	17,3
+25	9,2	13,8	18,4	23,0
+30	12,9	18,2	24,3	30,3



## Water Vapour Condensation

The maximum possible percentage of water vapour that can be absorbed becomes higher while the air is **heated**, but the obtained percentage of water vapour remains unchanged, and consequently the relative air humidity is reduced.

However, when the air is **cooled** the maximum possible percentage of water vapour that can be absorbed is continuously reduced, whereas the water vapour quantity contained in the air remains unchanged, and consequently the relative air humidity rises.

When the air is further cooled off the absorption capacity regarding the maximum possible water vapour quantity is continuously reduced until it is equal to the obtained percentage of water vapour. This is the dew point temperature.

If the air is cooled down below the dew point, the obtained percentage of water vapour will be higher than the maximum possible water vapour quantity.

*Water vapour is deposited.*

It condenses, is converted into water and thus is extracted from the air

Steamed up window panes in winter or steamed up bottles containing cold drinks are typical examples of condensation.

The higher the relative air humidity is, the higher is the dew point temperature, and consequently it is easier for the temperatures to fall below the dew point.

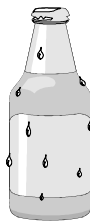

## Material Drying

Building materials/buildings can absorb considerable quantities of water; e.g. bricks 90-190 l/m<sup>3</sup>, heavy concrete 140-190 l/m<sup>3</sup>, calcareous sandstone 180-270 l/m<sup>3</sup>. Humid materials such as brickwork dries in the following way:

- ◇ The contained humidity flows from the inside of the material to its surface
- ◇ Evaporation takes place on the surface = water vapour is absorbed by the ambient air.
- ◇ The air enriched with water vapour is continuously circulating through the REMKO air dehumidifier. It is dehumidified and leaves the apparatus in a slightly heated up state to absorb again water vapour.
- ◇ By this the humidity contained in the material is continuously reduced; the material becomes dry.

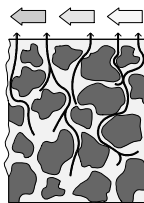

The generated condensate is collected in the apparatus and carried away.

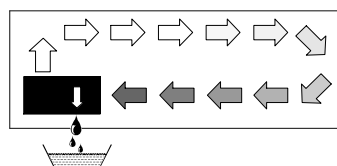

The air current is cooled off on its way through/via the evaporator until its temperature falls below the dew point. The water vapour condenses, it is collected in a condensate trap and carried away.

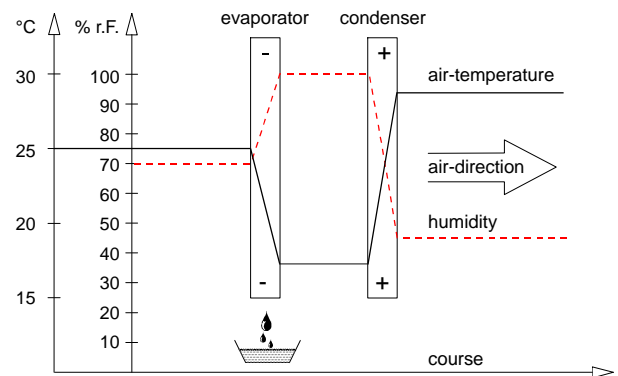

## Condensation Heat

The energy transferred from the condenser to the air consists of:

- ◇ The heat that was previously extracted in the evaporator.
- ◇ The electric driving energy.
- ◇ The condensation heat released by liquefying water vapour.

When the liquid condition is converted into a gaseous condition energy must flow back. This energy is called evaporation heat. It does not cause the temperature to raise but is used for the conversion from the liquid to the gaseous state. On the other hand energy is released when gas is liquefied, and this energy is called condensation heat.

The energy rate of evaporation and condensation heat is identical.

For water this is 2250 kJ / kg ( 4,18 kJ = 1kcal )

This shows that a relatively high energy rate is released through water vapour condensation.

If the humidity to be condensed is not generated by evaporation within the room, but fed from the outside, e.g. by aeration, the condensation heat released thereby contributes to room heating.

When materials or rooms are to be dried the heat energy flows in a circulation, i.e. it is consumed during evaporation and released during condensation. A larger amount of heat energy is generated when fed air is dehumidified, and this heat energy is expressed in the form of a rise in temperature.

*Generally the time needed for drying does not depend on the apparatus capacity, but it is determined by the speed at which the material or the parts of the building emit the humidity contained in them.*

# Safety Instructions

REMKO dehumidifiers will provide you with high utility and long life thanks to our extensive material, function and quality controls.

Dangers may arise nevertheless if the unit is used by persons not familiar with its operation or if the unit is not used for its intended purpose.

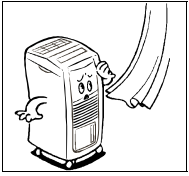

Ensure that the unit is set up at a safe distance from flammable materials.

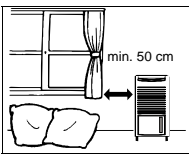

Do not set the unit up near curtains or drapes. Maintain a safety distance of at least 50 cm.

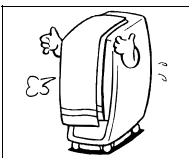

Ensure that the air intake and outlet openings are always clear of foreign objects.

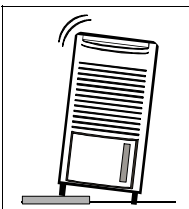

Ensure that the dehumidifier is solidly set up on a level surface. The unit may only be operated in an upright position.

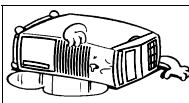

Do not attempt to use the unit while lying on its side or in any manner deviating from these instructions.

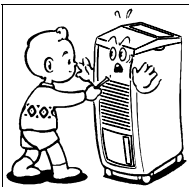

Do not insert any foreign objects into the air intake or outlet openings.

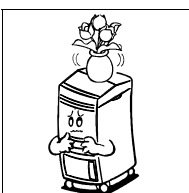

Do not place any heavy or warm objects on the unit.

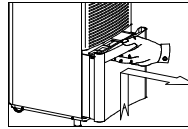

Empty the condensation tank before moving the unit.

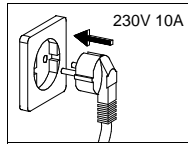

Connect this unit to a correctly installed, earthed and fused plug socket. *230V/50 Hz; 10A fuse.*

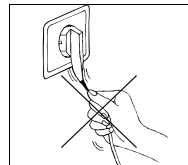

Do not pull on the power cable or bend it excessively. *This may result in damage to the cable.*



Wait at least five minutes before starting the unit after it has been moved.

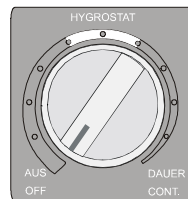

Stop the unit by setting the hygrometer to "OFF". Do not pull the power plug to stop the unit.

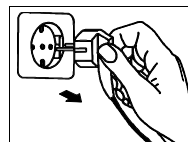

When unplugging the unit, always grasp the power plug. Do not pull the cable.

- ◇ Do not set up or operate the unit in rooms containing explosion hazards.
- ◇ Do not set up or operate the unit in atmospheres contaminated by oil, sulfur or salt.
- ◇ Do not expose the unit to direct streams of water.
- ◇ Do not move the unit while in operation.
- ◇ Protect all external cables against damage (including damage by rodents, etc.).
- ◇ Select extension cables that are suited to the device in terms of capacity, length and intended deployment.

# Unit Description

This unit is designed to provide simple, universal and fully automatic dehumidification.

It can be moved and set up with ease thanks to its compact dimensions.

The dehumidifier works according to the condensation principle and is equipped with a hermetically sealed cooling system and a quiet, low-maintenance radial fan as well as a power cable and plug.

The unit's fully automatic control system, continuously adjustable hygostat, condensation collection tank with integrated overflow protection and hose connections for the direct disposal of condensation guarantee trouble-free long-term use.

This dehumidifier conforms with the basic safety and consumer health requirements outlined in the relevant EU regulations to ensure its safe, simple deployment.

## Place of operation

The dehumidifier can be used in any room in which a dry atmosphere is required and in which excess humidity may result in damage (e.g. through mold or rot).

This unit is intended primarily for dehumidification of closed spaces such as:

- ◇ residential or basement rooms
- ◇ laundry or shower rooms
- ◇ weekend cottages, campers
- ◇ sports boats, yachts, etc.

or for the continuous dehumidification of:

- ◇ storage rooms, archives, laboratories
- ◇ baths, washing and locker rooms, etc.

## Function

Switching the unit on activates its fan and compressor.

The device operates on the condensation principle.

The **fan** draws humid air from the front of the unit across an air filter, the vaporizer, and the condenser behind it.

Heat is removed from the air by the **vaporizer**. The air is cooled to below the dew point and the water vapor in the air condenses as liquid water or frost on the blades of the vaporizer.

The vaporizer is defrosted by hot gas as required.

The **condenser** (heat exchanger) warms the cooled, dehumidified air and releases it into the room at approx. 10° to 15° above the ambient temperature.

The air that has been dehumidified in this manner thus mixes with the surrounding air. The continuous circulation of the room air through the unit will thus reduce the humidity in the room to the desired relative humidity.

Depending on the air temperature and relative humidity, condensation either drips into the **condensation trap** continuously or during the periodic defrosting phases. From there it passes through the integrated outlet into the **condensation tank** located below it.

Condensation can also be released via a hose to a drain below the unit during unattended long-term operation.

The condensation tank is equipped with a float and micro switch that stops the dehumidifier when the tank is full.

The unit switches off and the red warning lamp (TANK FULL) will light up.

The warning light will go out and the unit will restart when the emptied condensation tank has been replaced.

In **continuous operation** the condensation is continuously release via a hose connection.

The unit will then remain in operation until the required humidity has been reached.

## Illustration of functions

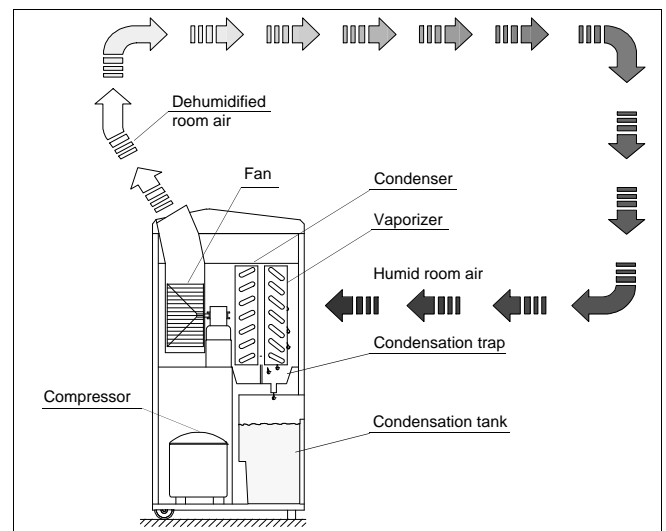

**This unit may only be used as described in this manual.**



**Other applications constitute improper use and will void the unit's warranty.**

# Installation

- ◇ Install the unit in a horizontal position to ensure the trouble-free drainage of condensate.
- ◇ Install the unit in the middle of the room, if possible, to ensure optimal air circulation.
- ◇ If this is not possible due to the on-site situation, please ensure that the air can be drawn into the front of the unit and exhausted at the back or the top air control flap without obstructions.
- ◇ Make sure to observe a minimum distance of 50 cm
- ◇ Do not install the unit directly near radiators or other heat sources.
- ◇ Make sure to keep the room to be dried and dehumidified closed, so that air from outside cannot penetrate into it.
- ◇ Entering into and going out of the room should be avoided if possible.
- ◇ You can obtain better air circulation if you place the unit at a height of approx. 1 m.

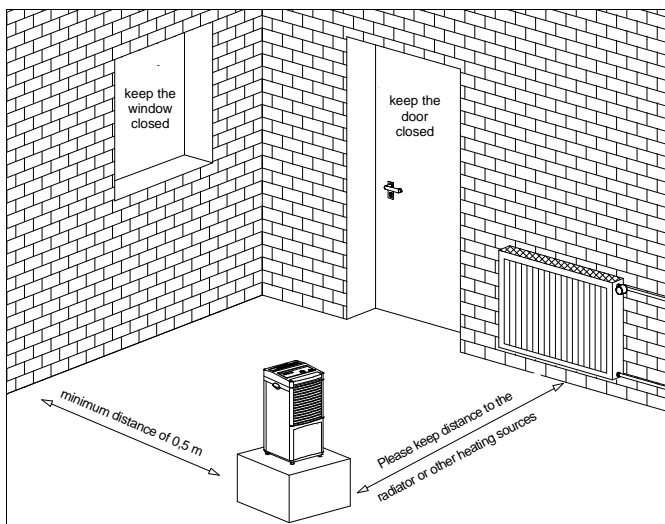

## Important Hints!

- ◇ Make sure that appropriate measures for maintenance and care are taken when the unit is installed in dusty surroundings as well as in stables with ammoniacal atmosphere  
*See chapter "Maintenance and Care".*
- ◇ The electrical connection of the unit is to be carried out according to DIN VDE 0100, part 704. It is to be connected to service entrances with residual current operated device.
- ◇ If the unit is installed in washhouses, showers or similar wet areas the user has to protect it by an adequate residual current operated device according to the relevant regulations.

# Starting

 **The filter of the unit is to be controlled and cleaned thoroughly before every use. If the air suction grille is dirty, please cleaned it up like shown in chapter "Maintenance and Service".**

## Starting the unit

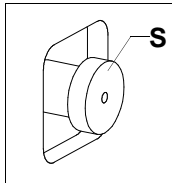

Ensure that the plug S is correctly installed in the hose connector on the rear of the unit.

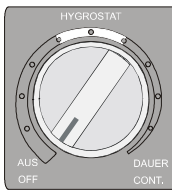

Turn the knob on the operating panel counterclockwise to the "OFF" position.

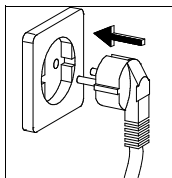

Insert the power plug into a correctly fused plug socket.  
**230V/1~ 50 Hz / 10 A fuse.**

## Important Hints:

- ◇ Connection cable extensions may only be used when they have been completely unrolled.
- ◇ If the condensat tank is not fitted correctly, the unit will not run.

 **After moving the unit, wait at least five minutes before starting it to prevent damage to the compressor.**

## Regulation with Hygrostat

The integrated hygrostat controls the switching functions for automatic operation.

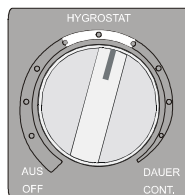

Select the required humidity with the hygrostat.

Approximate values:

CONT.	⇒	20 % r. F.
OFF	⇒	80 % r. F.
white area	⇒	40 % r. F.

A humidity of 45% to 60% is sufficient for residential rooms; a humidity of 40% to 45% should not be exceeded in storage rooms, archives, etc.

The unit will now switch itself on if the existing humidity is higher than the selected value.

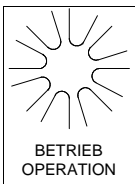

A green control lamp (OPERATION) indicates the correct function of the unit.

Once the unit has been activated, it will function automatically until either the selected humidity has been reached or the float switch indicates that the condensation tank is full.

### Important Hints:

- ◇ Wait approx. five minutes before restarting the unit after it has been switched off manually using the hygostat or by the float switch.  
*This safety measure will prevent an overload of the compressor.*
- ◇ Also allow the unit to settle for around 5 minutes before restarting it after it has been moved.

### Setting the air outlet direction

The dehumidified air is exhausted at the rear of the unit.

The direction of the exhaust air stream can be regulated with the adjustable air control flap. When this flap is closed, the dehumidified air exits through the exhaust in the rear wall of the unit.

Opening the flap will cause the air stream to exhaust upwards.

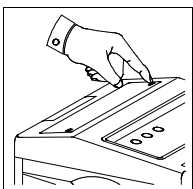

To open the flap, tap the corrugated surfaces.

The top side will tip downward, permitting you to adjust the air flow direction as required.

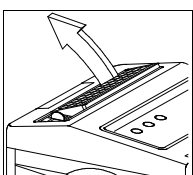

Ensure that the air outlet is unobstructed and that sensitive objects such as plants are not directly in the path of the air stream.

### Using the scent dispenser

The dehumidifier is equipped with a dispenser for scents to enhance the room air if desired.

The dispenser is located in the outlet area of the air control flap. When the flap is opened, the scent is distributed throughout the room by the dehumidified air.

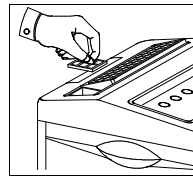

Remove the small grille lid to fill the dispenser with a scent of your choice.

### Automatic defrosting

The humidity in the room air condenses when cooled and covers the vaporizer blades with frost or ice.

This frost or ice must be thawed off from time to time. The integrated automatic defrosting function performs this function, thawing the vaporizer with hot gas at given intervals.

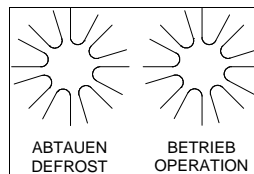

Dehumidification is briefly interrupted during the defrosting operation. A green control lamp (DEFROST) is lit while the unit is defrosting.

### Condensation tank

The integrated condensation tank must be emptied from time to time.

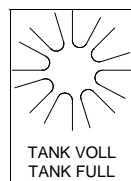

A red warning lamp (TANK FULL) lights and dehumidification is interrupted when the tank is full.

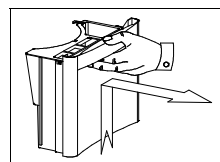

Carefully remove the full condensation tank.

Lift the tank slightly and carefully pull it out toward the front. The contents of the tank can be poured down a drain.

We recommend cleaning the tank with a clean cloth.

Carefully reinsert the cleaned tank into the unit. The red warning lamp will go out and automatic operation will continue.

## Continuous operation

A connector for a standard 1/2" water hose (not included) is provided on the rear of the unit.

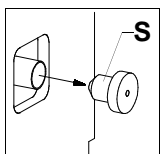

Remove the plug S from the connector on the rear of the unit.

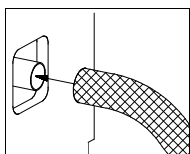

Attach a sufficiently long hose to the connector. The condensation can now be allowed to flow into a drain, for example, during unattended continuous operation.



**Ensure that the hose slopes downwards toward the drain to permit condensation to drain without obstructions.**

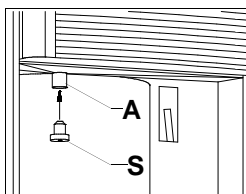

Remove the condensation tank and close the drain A below the condensation trap with the plug S. Replace the condensation tank.

To convert the unit from continuous to normal operation, perform these steps in reverse order.



**To prevent spillage, ensure that the plug is correctly positioned!**

## Working rang

Dehumidification performance depends exclusively upon the design of the room, the room temperature and humidity and the correct observance of the setup instructions.

See chapter "Installation".

The dehumidification performance increases with the room temperature and relative humidity.

For a reliable operation the following working-range is valid.

- ◇ Room temperature between 6 °C and 32 °C
- ◇ Relative humidity between 40% and 100%



**The proper functioning of the unit cannot be guaranteed at temperatures below 10 °C or a relative humidity of less than 40%.**

## Discard the Unit



Turn the knob of the hygrometer to the "OFF" position.

## Prior to longer idle periods

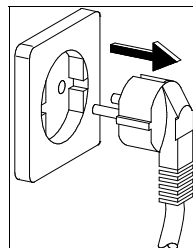

Remove the plug from the plug socket.

Wrap the power cable on the retainer on the rear panel of the unit.

- ◇ Drain the condensation tank and wipe it dry with a clean cloth.  
*Pay attention to dripping condensation from the vaporizer blades.*
- ◇ Clean the air intake and charcoal filters according to their instructions.  
*Charcoal filters only ETF 150.*
- ◇ Protect the unit from dust with a plastic cover.
- ◇ Store the unit in an upright position away from dust and direct sun light.

## Transport Instructions

The unit features 2 casters, a handle and two recessed grips on the sides for ease of transport.



**Do not move the unit by pulling on the power cable!**

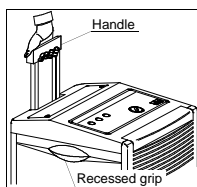

The handle is integrated in the rear panel of the unit and can be pulled out upwards.

The recessed grips are located in the side panels.

### Note:

- ◇ Always switch the unit off and unplug it before moving.
- ◇ Next, empty the condensation tank.
- ◇ Please pay attention to dripping condensation from the vaporizer blades.



**After moving the unit, wait at least five minutes before starting it to prevent damage to the compressor.**

## Cleaning the Filter

The dehumidifier features an air intake filter to prevent damage to the unit and improve the room climate.

The unit ETF 150 also has a charcoal filter that requires replacement when contaminated. The charcoal filter is intended solely to improve the quality of the room air and is therefore not required for operation.

Check the air filters at least every two weeks and clean or replace them according to the instructions to prevent loss of performance or device malfunctions.



1. Shut the unit down by turning the knob to the "OFF" position.
2. Remove the plug from the plug socket.

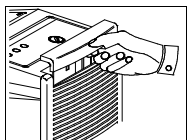

3. Pull the entire filter frame containing the filters upwards out of the unit.

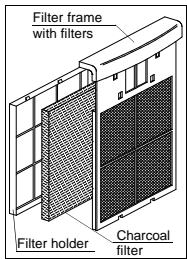

4. Unhook the filter holder at the rear (only ETF 150).
5. Remove (only ETF 150) the charcoal filter and replaced as required.  
*The charcoal filter insert cannot be cleaned.*

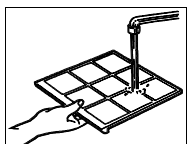

6. Clean the air intake filter in the filter frame.
  - With lukewarm water.  
*Dirty side down*
  - With a vacuum cleaner.  
*Dirty side up.*

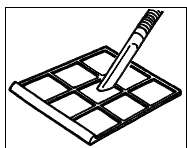

7. Clean heavily contaminated filters in lukewarm, max. 40°C soapy water.  
*Rinse with clean water afterwards.*

 **The air intake filter must be completely dry and intact before it is replaced to prevent damage to the charcoal filter.**  
**Only ETF 150**

8. Reinstall the filter frame carefully after cleaning or replacing the air intake filter.
9. Ensure that the frame is correctly seated and positioned.

 **Never operate the unit without the filter frame!**

## Maintenance and Service

Regular care and the observation of a number of basic rules will ensure the dehumidifier's long life and reliable operation.

The unit should be inspected and cleaned thoroughly after each long period of operation, at a minimum once a year.

All moving parts feature low-maintenance long-life lubrication.

The complete cooling system is hermetically sealed and contains no user-serviceable parts. **It may only be serviced by authorised repair facilities.**

- ◇ Ensure that the interior and exterior of the unit remains free of dust and other deposits. Clean the unit only with a dry or dampened cloth.  
*Do not use a water jet!*
- ◇ Do not use aggressive cleansers or cleaning products containing solvents.
- ◇ Be sure to use suitable cleaning products should the unit become extremely dirty.
- ◇ Regularly check the air intake filter / charcoal filter (only ETF 150) and the exhaust grille for soiling.  
*Clean or replace them as required.*

 **Always remove the power plug from the plug socket when working on the unit!**

### Cleaning the condenser and vaporizer

These operations require opening the unit housing and should only be performed by authorised service personnel.

- ◇ Clean the condenser and vaporizer with an air jet, vacuum cleaner or a soft brush. Do not use a water jet.  
*Caution: the blades bend easily!*
- ◇ Carefully clean the interior surfaces of the unit, condensation trap, inner condensation tube with hose connector (do not forget plug) as well as the fan blades and housing and wipe dry.
- ◇ Reinstall all removed components.
- ◇ Test the functions of the unit and perform an electrical safety check!

 **The cooling and electrical systems may only be serviced by authorised service centres!**

### Important recycling note

- ◇ The dehumidifier uses environmentally-friendly R134a refrigerant which is not hazardous to the ozone layer.
- ◇ The refrigerant / oil mixture in the unit must be disposed of in accordance with your local regulations.

# Exploded View

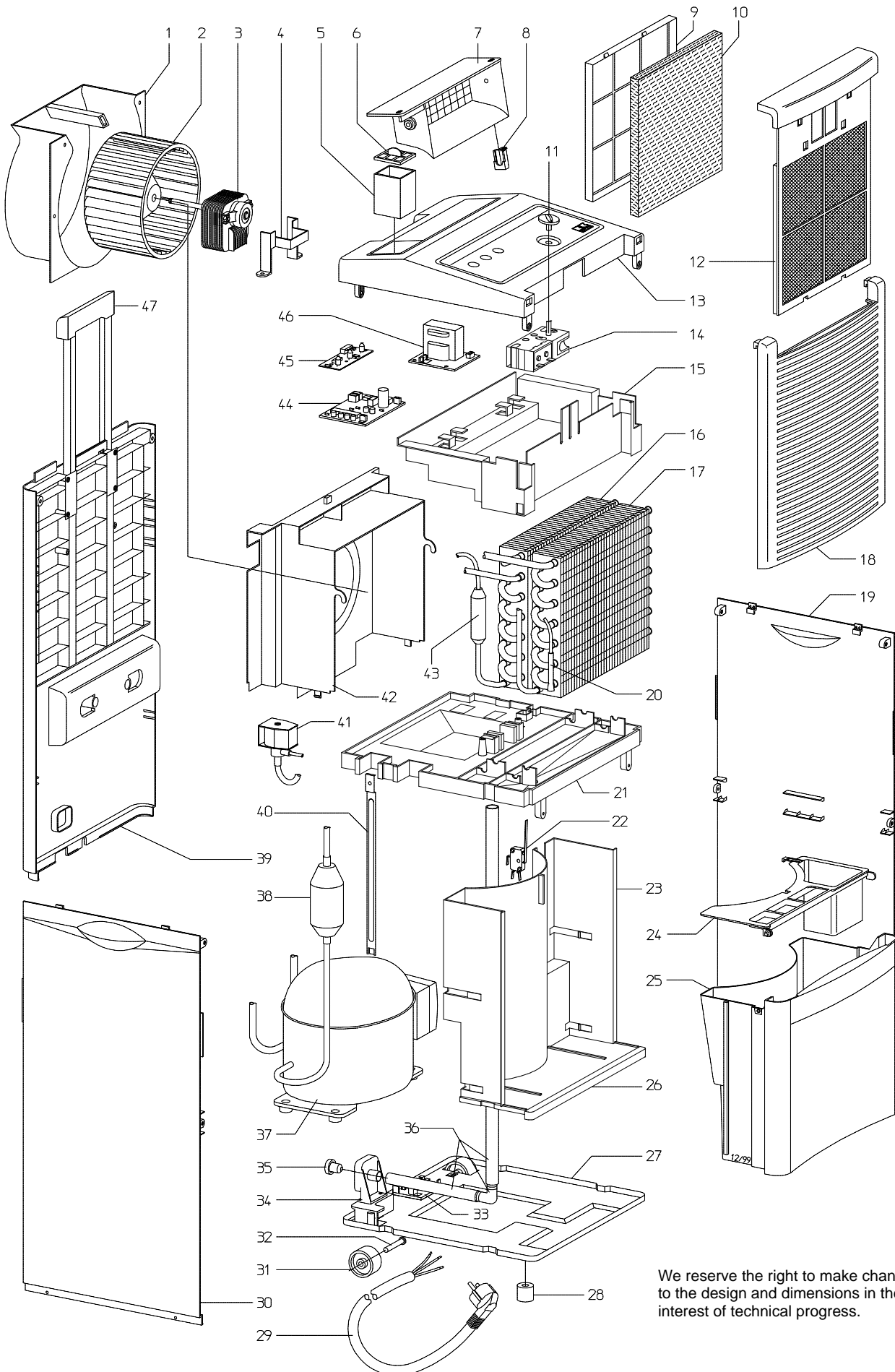

We reserve the right to make changes to the design and dimensions in the interest of technical progress.

# Spare Part List

No.	Designation	ETF 100	ETF 150
		Ref. No.	Ref. No.
1	Fan housing	1103502	1103502
2	Fan blade	1103503	1103503
3	Fan motor	1103504	1103504
4	Handle	1103505	1103505
5	Scent dispenser	1103506	1103506
6	Cover	1103507	1103507
7	Air control flap	1103508	1103508
8	Retaining clip	1103509	1103509
9	Filter frame	_____	1103545
10	Charcoal filter	_____	1103501
11	Adjuster knob	1103510	1103510
12	Air intake filter	1103511	1103511
13	Upper cover	1103512	1103512
14	Hygrostat	1103513	1103513
15	Electronics box	1103514	1103514
16	Condenser	1103546	1103546
17	Vaporizer	1103516	1103516
18	Intake grille	1103517	1103517
19	Side cover, right	1103518	1103518
20	Temperature sensor	1103519	1103519
21	Condensation trap	1103551	1103551
22	Microswitch	1103537	1103537
23	Compressor separator	1103521	1103521
24	Float	1103522	1103522
25	Condensation tank, complete	1103523	1103523
26	Tank floor	1103524	1103524
27	Device floor	1103525	1103525
28	Support, front	1103526	1103526
29	Power cable with plug	1103527	1103527
30	Side cover, left	1103528	1103528
31	Transport caster	1103529	1103529
32	Axis	1103531	1103531
33	Strain relief	1103532	1103532
34	Hose connector	1103552	1103552
35	Plug	1103553	1103553
36	Condensation tube	1103554	1103554
37	Compressor, complete	1103548	1103548
38	Accumulator	1103547	1103547
39	Rear panel	1103555	1103555
40	Support brace	1103538	1103538
41	Solenoid	1103530	1103530
42	Fan cover	1103539	1103539
43	Dry filter	1103549	1103549
44	Control board	1103541	1103541
45	Display board	1103542	1103542
46	Power board	1103543	1103543
47	Transport handle	1103544	1103544

When ordering spare parts, always specify both the part number and the unit number (see name plate).



**This dehumidifier may only be used as described in this manual.**

**Other applications constitute improper use and will void the unit's warranty.**



Warranty claims will only be honored if the ordering party or end customer promptly completes the **warranty certificate** included with every REMKO dehumidifier and returns it to REMKO GmbH & Co. KG.

## In Case of Troubles

The functions of this dehumidifier were tested several times during the course of its production.

Should a fault occur nevertheless, please check the following points in the order listed below.

 **Always remove the power plug from the plug socket when working on the unit!**

### Unit does not start:

- ◇ Check AC power.  
*230V/1~ 50 Hz.*
- ◇ Check permanently installed circuit breaker.  
*10 A.*
- ◇ Check power plug.
- ◇ Check condensation tank for fill level and proper seating.  
*Red warning lamp lit.*
- ◇ Check micro switch function.
- ◇ Check hygrostat settings.  
*Setting must be lower than the humidity in the room.*

### Unit running, no condensation formation:

- ◇ Check room temperature.  
*The working range of the unit is between 6°C and 32°C.*
- ◇ Check relative humidity.  
*Min. 40%.*
- ◇ Check hygrostat setting and choose a lower setting if required
- ◇ Check air intake filter/charcoal filter for contamination.  
*Clean or replace as required*
- ◇ Check exchanger blades for soiling.  
*Let it clean as required.*
- ◇ Vaporizer is heavily iced up.  
*Check automatic defrosting and/or room temperature.*
- ◇ Vaporizer temperature not under room temperature.  
*Check automatic defrosting and/or compressor*

### Unit is too loud (vibration) or leaks condensation:

- ◇ Unit standing on uneven surface (not upright).
- ◇ Plug not correctly installed.
  1. *in the drain of condensation trap.*
  2. *in the hose connector on rear panel.*

Should the unit still not be working despite these checks, please contact an authorised service centre.

 **Repairs of the cooling and electrical systems may only be performed by an authorised service centre!**

## Technical Data

Model		ETF 100	ETF 150
Working temperature range	°C	6 - 32	6 - 32
Working humidity range	% rel.	40-100	40-100
Max. dehumidification	l/day	14	15
at 30 °C / 80% rel. hum.	l/day	12	13
Air performance	m <sup>3</sup> /h	115	105
Refrigerant		R134a	R 134a
Refrigerant volume	g	200	200
Electrical connection	V	230/1~	230/1~
Frequency	Hz	50	50
Max. nominal current	A	2,5	2,5
Max. power consumption	W	395	395
Circuit breaker (building)	A	10	10
SPL L <sub>pA</sub> 1m <sup>1)</sup>	dB (A)	45	45
Dimensions	depth	mm	310
	width	mm	300
	height	mm	570
Weight	kg	17.0	17,5

1) noise measurement as per DIN 45635 - 01 - KL 3

## Wiring Diagram

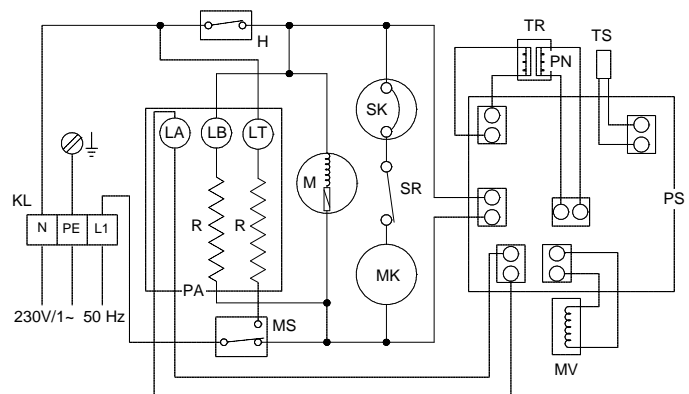

H	= Hygrostat	PN	= Power board
KL	= Terminal strip	PS	= Control board
LA	= LED - defrost	R	= Protective resistor
LB	= LED - operation	SK	= Starting unit
LT	= LED - tank full	SR	= Start relay
M	= Fan motor	TS	= Temperature sensor
MK	= Compressor	TR	= Transformer
MS	= Microswitch		
MV	= Solenoid		
PA	= Display board		

# Maintenance and Service Log

Unit type: .....

Unit number: .....

	1	2	3	4	5	6	7	8	9	10	11	12	13	14	15	16	17	18	19	20
Unit cleaned – exterior –																				
Unit cleaned – interior –																				
Condenser cleaned																				
Vaporizer cleaned																				
Fan blades cleaned																				
Dust filter cleaned or replaced																				
Protective equipment checked																				
Unit checked for damage																				
All mounting screws checked																				
Electrical safety check																				
Test run																				

Remarks: .....

.....

1. Date:..... ..... Signature	2. Date:..... ..... Signature	3. Date:..... ..... Signature	4. Date:..... ..... Signature	5. Date:..... ..... Signature
6. Date:..... ..... Signature	7. Date:..... ..... Signature	8. Date:..... ..... Signature	9. Date:..... ..... Signature	10. Date:..... ..... Signature
11. Date:..... ..... Signature	12. Date:..... ..... Signature	13. Date:..... ..... Signature	14. Date:..... ..... Signature	15. Date:..... ..... Signature
16. Date:..... ..... Signature	17. Date:..... ..... Signature	18. Date:..... ..... Signature	19. Date:..... ..... Signature	20. Date:..... ..... Signature



**This unit may only be serviced by authorised personnel as stipulated in the relevant regulations.**



**REMKO GmbH & Co. KG**

Klima- und Wärmetechnik

D-32791 Lage • Im Seelenkamp 12

D-32777 Lage • PO Box 1827

Phone +49 (5232) 606 - 0

Fax +49 (5232) 606260