



REMKO ETF 240

Portable Air Dehumidifier



Operation
Technology
Spare Parts

Operating Instructions

Read these instructions carefully before setting up/operating the unit!

Our guarantee becomes null and void if the unit is used, set up or maintained improperly, or if modifications are made to the supplied unit without our prior consent.

Subject to alterations.

Portable air dehumidifier REMKO ETF 240

CE

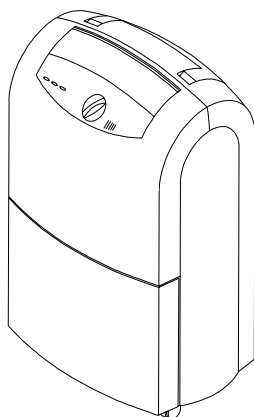

Contents	Page	Contents	Page
Air Dehumidification	4	Maintenance and Service	10
Safety Instructions	6	Troubleshooting	10
Description of the Unit	6	Technical Data	11
Setup	7	Wiring Diagram	11
Control Panel	7	Customer Service and Guarantee	11
Initial Operation	8	Exploded View	12
Shutting Down the Unit	9	Spare Part List	13
Cleaning the Filter	9	Maintenance and Service Log	14

 Always keep these operating instructions near or on the unit. 

Air Dehumidification

The processes that take place during air dehumidification are based on physical laws. We will try to describe these in a simplified form to give you a general idea about the principle of air dehumidification.



The use of REMKO air dehumidifiers

- ◇ No matter how well doors and windows are insulated, dampness and moisture penetrate even thick concrete walls.
- ◇ It can take up to 1 or 2 months for the water used in the production of concrete, mortar, plaster, etc. to dry.
- ◇ The moisture that penetrates brickwork as a result of flooding is released very slowly.
- ◇ E.g. this is also the case regarding moisture contained in materials in storage.

The moisture escaping from parts of buildings or materials (water vapour) is absorbed by the ambient air. Consequently the humidity of the air increases which results in corrosion and in formation of mildew, decay, flaked off paint and other unwanted damage.

The diagram below is an example of the corrosion rate of metal at different air humidity levels.

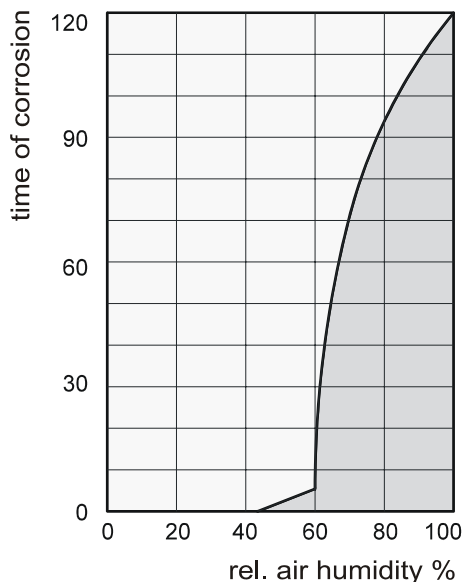

As you can see, the corrosion rate is insignificant at a relative air humidity of less than 50 % and at a humidity rate of less than 40 %, it can even be ignored. When the relative humidity exceeds 60 %, the corrosion rate increases considerably.

This limit for damage caused by humidity also applies for many other materials, such as powdery substances, packing materials, wood, and electronic devices.

There are two different ways of drying buildings:

1. By heating and exchanging the air:

The ambient air is heated to absorb moisture and expelled to the outside. However, the total generated energy is lost with the expelled humid air.

2. By dehumidifying:

The humid air in the closed room is continuously dehumidified based on the principle of condensation.

With respect to energy consumption, dehumidification offers one important advantage:

Energy is only needed for the existing room volume. The mechanical heat released during the dehumidification process increases the room temperature slightly.

When used properly, the air dehumidifier consumes only approx. 25 % of the energy to be supplied according to the "heating and ventilation" principle.

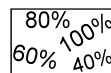

Relative air humidity

Ambient air is a gas mixture which always contains a certain percentage of water as water vapour.

This percentage of water is indicated in g per kg of dry air (absolute water content).

1 m³ of air weighs approx. 1.2 kg at 20° C.

Depending on the temperature, each kg of air can only absorb a defined quantity of water vapour. When this quantity has been absorbed, the air is "saturated" and has a relative humidity of 100 %.

Relative air humidity is defined as the ratio between the percentage of water vapour contained in the air at the moment in question and the maximum possible percentage of the water vapour when the temperature is the same.

The capacity of air to absorb water vapour increases when the temperature rises. This means that the maximum possible (= absolute) water content is increased as the temperature increases.

Temp. °C	Water vapour content in g/m ³ at an air humidity of			
	40%	60%	80%	100%
-5	1.3	1.9	2.6	3.3
+10	3.8	5.6	7.5	9.4
+15	5.1	7.7	10.2	12.8
+20	6.9	10.4	13.8	17.3
+25	9.2	13.8	18.4	23.0
+30	12.9	18.2	24.3	30.3



Water vapour condensation

The maximum possible amount of water vapour that can be absorbed becomes higher when the air is **heated**, but the water vapour content remains unchanged and consequently the relative air humidity is reduced.

However, when the air is **cooled**, the maximum possible amount of water vapour that can be absorbed is continuously reduced although the water vapour quantity contained in the air remains unchanged and consequently the relative air humidity rises.

When the air is further cooled, the absorption capacity with respect to the maximum amount of water vapour possible is continuously reduced until it is equivalent to the water vapour content. This is the dew point temperature.

If the air is cooled below the dew point, the water vapour content will be higher than the maximum amount of water vapour possible.

Water vapour is expelled.

It condenses, is converted into water and thus extracted from the air.

Steamed up window panes in winter or steamed up bottles containing cold drinks are typical examples of condensation.

The higher the relative air humidity is, the higher the dew point temperature is and consequently the easier it is for the temperatures to fall below the dew point.

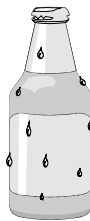

Drying materials

Building materials/buildings can absorb considerable amounts of water; e.g. bricks 90-190 l/m³, heavy concrete 140-190 l/m³, calcareous sandstone 180-270 l/m³. Damp materials such as brickwork dry as described below:

- ◇ The moisture contained in the material flows from the inside to the surface
- ◇ Evaporation takes place on the surface = water vapour is absorbed by the ambient air.
- ◇ The air augmented with water vapour continuously circulates through the REMKO air dehumidifier. It is dehumidified and leaves the unit in a slightly warm state to absorb water vapour again.
- ◇ This allows the moisture contained in the material to be continuously reduced; the material becomes dry.

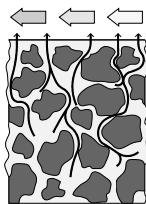

The resulting condensation is collected in the device and drained.

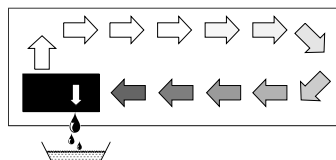

The air current is cooled on its way through/via the evaporator until its temperature falls below the dew point. The water vapour condenses, is collected in a condensation tray and drained.

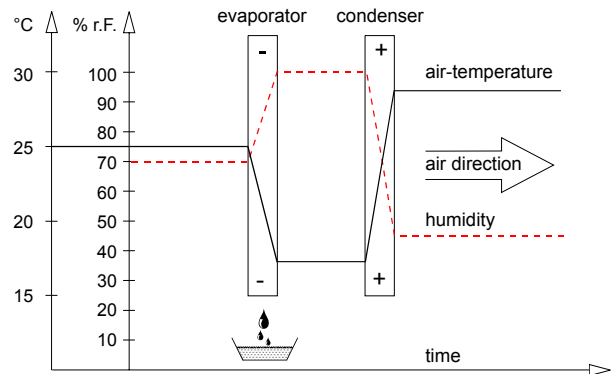

Condensation heat

The energy transferred from the condenser to the air consists of:

- ◇ The heat that was previously extracted in the evaporator.
- ◇ The electric operating power.
- ◇ The condensation heat released by liquefying water vapour.

When the liquid is converted into a gaseous state, energy must flow back. This energy is called evaporation heat. It does not cause the temperature to rise but is used for the conversion from the liquid to the gaseous state. Conversely, energy is released when gas is liquefied, and this energy is called condensation heat.

The energy produced from evaporation and condensation heat is identical.

For water this is 2250 kJ / kg (4.18 kJ = 1kcal)

This shows that a relatively high amount of energy is released through water vapour condensation.

If the humidity to be condensed is not generated by evaporation within the room, but supplied from the outside, e.g. by ventilation, the condensation heat released thereby contributes to heating the room.

When materials or rooms are to be dried, the heat energy flows in a cycle, i.e. it is consumed during evaporation and released during condensation. A larger amount of heat energy is generated when supplied air is dehumidified which is expressed as a rise in temperature.

Generally, the time needed for drying does not depend on the unit capacity, but is determined by the speed at which the material or the parts of the building release the moisture contained in them.

Safety Instructions

Extensive tests have been conducted on the material, functionality and quality of this unit before it was shipped.

Hazards may nevertheless arise if the unit is used by persons not familiar with its operation or if the unit is not used for its intended purpose!

Please also make sure to follow these safety instructions.

- ◇ The unit may not be set up or operated in rooms susceptible to explosions.
- ◇ The unit may not be set up and operated in rooms whose atmosphere is contaminated by oil, sulfur, chlorine or salt.
- ◇ The unit must be securely placed in an upright position.
- ◇ The unit may not be exposed to a direct stream of water.
- ◇ The air intake and outlet openings may never be blocked.
- ◇ The air intake side must always be free of dirt and loose objects.
- ◇ Never insert foreign objects into the unit.
- ◇ The unit may not be covered or transported during operation.
- ◇ The electrical cables outside the unit must be protected from being damaged (e.g. by animals).
- ◇ Make sure that extension cables are suitable in terms of capacity, length and intended use.
- ◇ The unit may only be transported in an upright position, the condensation tank must be emptied each time before the unit is moved.
- ◇ The unit may not be operated for a different purpose or other than as described in this manual.
In cases of non-compliance, we assume no liability and the guarantee becomes null and void.

 **Work on the cooling system and the electrical system may only be performed by authorised personnel!**

Description of the Unit

The unit has been designed for automatic, universal, smooth air dehumidification. Its compact dimensions make it easy to transport and set up.

The unit works on the principle of condensation. It is equipped with a closed-loop cooling system, a quiet fan requiring little maintenance and a power cord with plug.

The unit has control lights on the control panel to check unit functions.

The unit's fully automatic control system, continuously adjustable hygrostat, condensation collection tank with integrated overflow protection and hose connections for the direct disposal of condensation guarantee trouble-free long-term use.

The unit meets the basic safety and health requirements found in the relevant EU regulations. It is safe and easy to operate.

Unit setup locations

The unit is used in rooms where dry air is a priority to avoid consequential financial losses (e.g. as a result of a buildup of mildew).

The unit is primarily used to dry and dehumidify:

- ◇ Living rooms, bedrooms, showers or basements.
- ◇ Kitchens, weekend houses, caravans.

And to keep the following dry on a permanent basis:

- ◇ Storage areas, archives, laboratories.
- ◇ Bathing, washing, changing rooms, etc.

Function

The unit works on the principle of condensation.

The **fan** sucks the moist ambient air into the back of the unit via the air filter, the evaporator and the condenser located behind the evaporator.

Heat is extracted from the ambient air at the cold **evaporator**. The ambient air is cooled until it falls below the dew point and the water vapour contained in the air turns into condensation or frost on the evaporator fins.

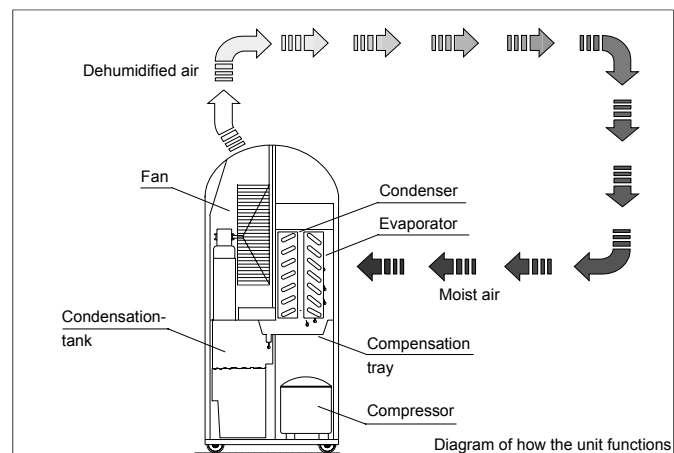

The dehumidified, cooled air is reheated in the **condenser** (heat-exchanger) and then released at a temperature of approximately 5 degrees above room temperature.

This air, which is now drier, is mixed again with the ambient air. The humidity of the air is gradually reduced to the desired relative humidity through the continuous circulation of ambient air by the unit.

Depending on the air temperature and the relative humidity, the condensed water drips out steadily or only during periodic defrosting phases into the **collection tray** and then into the **condensation tank** beneath it through the integrated drainage lines.

A float regulator flap is installed in the condensation tank that interrupts dehumidification operation via a microswitch when the tank is full.

The unit switches off and the LCD display "Tank full" lights up. It goes off again when the condensation tank is emptied and replaced. The unit then restarts after a delay of approximately 2 minutes.

For unsupervised, continuous operation of the unit, the condensation is continuously drained via an external water hose.

Setup

Follow the instructions below to ensure the to optimum, economical and safe operation of your unit.

- ◇ The unit must be securely placed in an upright position so that condensation can drain freely into the condensation tank.
- ◇ If possible, place the unit in the middle of the room to ensure optimum air circulation.
- ◇ Maintain a minimum distance of 50 cm to walls.

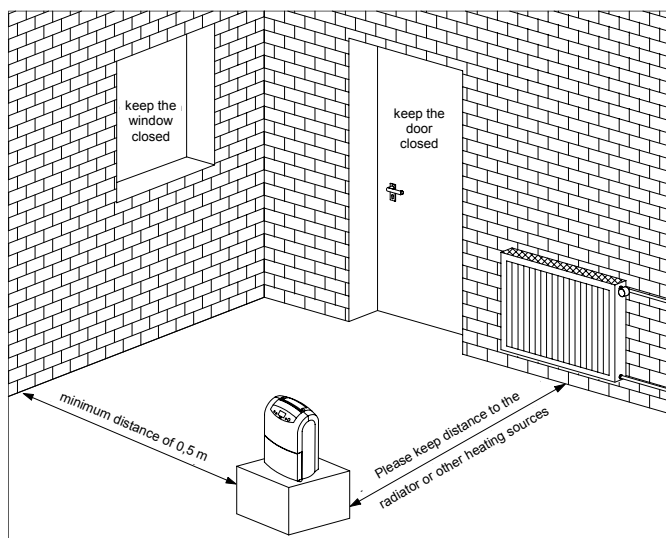

- ◇ Make sure that the air can flow freely into the back of the unit and out of the upper air flap.
- ◇ Do not place the unit in the direct vicinity of radiators or other heat sources.
- ◇ Keep the room to be dried or dehumidified closed so that air from the surroundings cannot get in.
- ◇ Keep windows and doors closed and avoid entering and leaving the room frequently.

- ◇ If the unit is in operation in a dusty environment, the appropriate service and maintenance measures are to be undertaken in accordance with the specific conditions.
See chapter "Maintenance and Service".

- ◇ You can improve the air circulation if you set up the unit at a height of approximately 1 m.

Important information about the electrical connection

- ◇ The electrical connection of the unit is to be carried out in accordance with DIN VDE 0100, Part 704 to electrical supply points with residual current circuit breakers.
- ◇ When the unit is set up in wet areas such as in bathrooms or kitchens, the unit must be equipped by the customer with a residual current circuit breaker that meets regulations.

Control Panel

The hygostat and the control lights are located on the control panel.

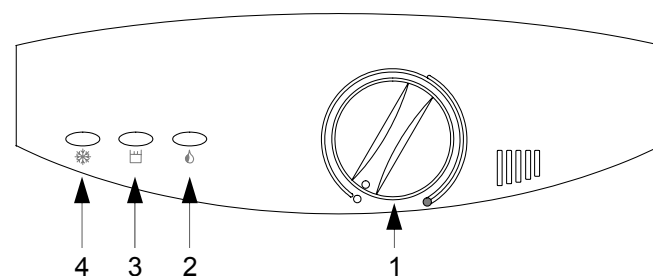

1 Hygostat

Select the humidity level in the room where the unit is located using the gradually adjustable hygostat.

2 "Dehumidification" control light

This light indicates that the unit is operating properly.

3 "Tank full" control light

This light indicates that the condensation tank is full and the unit has switched off as a result.

4 "Defrost" control light

This light indicates that the automatic defrost system built into the unit has switched on the defrost cycle.

Initial Operation

Prior to initial operation or to meet local requirements, the air intake and outlet openings must be inspected for foreign bodies and the air intake filter for dirt.

Blocked or dirty grilles and filters must be cleaned immediately. See chapter "Maintenance and Service".

Important instructions prior to operation

- ◇ Extension cords must be sufficiently thick.
- ◇ Extension cords can only be used if they are completely extended or rolled up!
- ◇ Do not use the power cord to pull the unit.
- ◇ After being switched on, the unit operates fully automatically until it is switched off by the float regulator of the full condensation tank.
- ◇ The condensation tank must be inserted properly. *Otherwise the unit does not work!*
- ◇ If, in continuous operation, the unit is to work with an external condensation connection, read the corresponding section on this page.
- ◇ The unit is equipped with a safety mechanism which stops the compressor from the switching right back on again after the unit has been switched off, thus preventing damage to the compressor.
The compressor switches on only after 3 minutes have elapsed.

 **At room temperatures below 10 °C and a relative humidity of less than 40 %, we no longer guarantee that the unit performs efficiently.**

Initial operation of the unit

1. Turn the knob on the operating panel counterclockwise to the "OFF" position.
2. Insert the power plug into a correctly fused plug socket.
3. Select the required humidity in the room where the unit is located on the hygrosat.
4. You can find the approximate adjustment value in the following section.
5. Keep in mind that the compressor only switches on after 3 minutes have elapsed.
Safety mechanism.

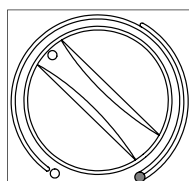
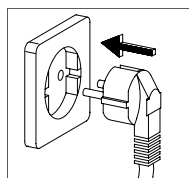
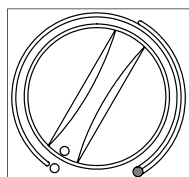

Information on dehumidification performance

The dehumidification performance is dependent only on the spatial composition of the room, the room temperature, the relative humidity and following the instructions in the chapter entitled "Setup".

The maximum dehumidification performance is achieved by opening the air flap completely.

The higher the room temperature and the relative humidity, the greater the dehumidification performance is.

For use in residences, a humidity level of approximately 45 to 60 % is sufficient while a humidity level of 40 to 45 % may not be exceeded in storage areas, archives, etc.

Hygrosat setting for the recommended humidity in residences.
Approx. 50 %.

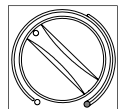

Hygrosat setting for the recommended humidity in archives.
Approx. 40 %.

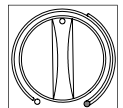

Hygrosat setting for minimum humidity in the room where unit is located.
The unit is in continuous operation.

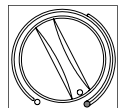

Setting the air outlet direction

The dehumidified ambient air is expelled from the top of the unit. The adjustable air flap can be used to change the direction of the air being expelled.

To open the air flap, press on the rear surface.
The front side opens upwards. You can adjust the direction of the air any way you want.



Please also observe the following.

- ◇ If possible, create a flow of air going upwards by opening the flap completely.
- ◇ Make sure that nothing is blocking the air from being expelled.
This is the only way to guarantee optimum unit operation.
- ◇ Make sure that sensitive objects, such as plants in the room, are not directly in the path of the expelled air.

Condensation tank

It is necessary to empty the integrated condensation tank from time to time.

The unit stops dehumidifying when the tank is full. The "Tank full" control light indicates that the unit has switched off for this reason.

Emptying the condensation tank

1. Carefully pull out the tank towards you.
2. Pour the condensation into a drain.
3. Clean the tank with a clean towel.
4. Carefully reinsert the tank into the unit.
5. Keep in mind that the unit only starts when the tank has been correctly inserted.
The red warning lamp (Tank full) will go out and automatic operation will continue.

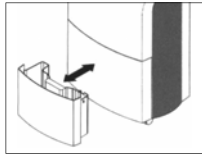

Continuous operation with an external condensation hose.

The unit must be equipped with a connection adapter on the left side. A standard 1/2" water hose can be connected here.

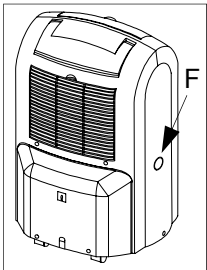

1. Using a suitable tool, break the cover F of the connection adapter from the unit wall.
Only necessary for the initial connection.
2. Connect a drainage hose that is sufficiently long to the connection adapter.

When the unit is in continuous operation, the condensation can now be directed, for example, to a drain at a lower level.



Make sure that the hose is placed at an incline to the drain so that the condensation is not blocked from flowing out of the condensation tank!

Automatic defrost

The humidity contained in the ambient air condenses when cooled and covers the evaporator fins with frost or ice depending on the air temperature and the relative humidity. This frost or ice buildup is automatically defrosted from the unit.

During the defrost phase, the dehumidification mode is briefly interrupted. The "Defrost" control light indicates that the defrost cycle is switched on.

Unit transport

The unit is equipped with wheels and a handle to make it easy to transport.

- ◇ Prior to moving the unit, switch the unit off and unplug it.
- ◇ Then empty the condensation tank.
Watch out for condensation that drips out.
- ◇ Do not use the power cord to pull the unit.

Shutting Down the Unit

Turn the knob of the hygostat to the "OFF" position.

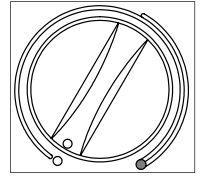

Prior to longer periods of non-operation

1. Unplug the power cord.
2. Empty the condensation tank and dry it with a clean towel.
Watch out for condensation that drips out.
3. Follow the instructions for cleaning the air intake filter.
4. To prevent dust from getting inside the unit, protect it with, for example, a plastic cover.
5. Store the unit in an upright position in a location protected from dust and direct sunlight.

Cleaning the Filter

To prevent damage to the unit, it is equipped with an air intake filter.

The air intake filter must be inspected as necessary, however, at least every two weeks, and cleaned if required to prevent its performance from suffering or problems with the unit.

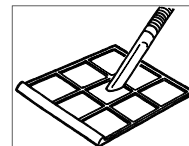
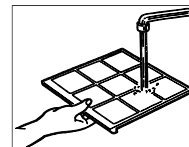
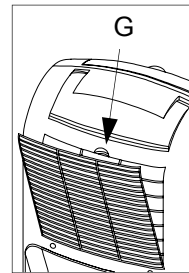

1. Switch the unit off by pressing the "On/Off" button.
2. Reach into the opening G and pull the air intake filter out of the unit.
3. Clean the air intake filter with warm water or with a vacuum cleaner.
4. Remove heavy dirt by rinsing the unit in a soapy solution at a maximum temperature of 40 °C.
Then rinse with clean water.
5. Keep in mind that the air intake filter may not be damaged and must be completely dry before being replaced to prevent damage to the unit.



The unit may never be operated without the air intake filter!

Maintenance and Service

Regular maintenance and observance of some basic principles are required to ensure a long service life and to keep the unit functioning properly.

However, the unit should be inspected at least once a year and thoroughly cleaned after long periods of use.

All movable parts have a permanent lubrication that requires little maintenance. The entire cooling system is a low-maintenance, closed-loop system and may only be serviced by authorised service centres.

 **Before performing any work on the unit, make sure to unplug power cord!**

- ◇ Keep the unit free of dust and other deposits.
- ◇ Use only a dry or slightly moist towel to clean the unit.
Do not expose it to a direct stream of water.
- ◇ Do not use abrasive cleaning agents or cleaning products containing solvents; only use suitable cleaning products even when the unit is extremely dirty.
- ◇ Check the air intake filter for dirt on a regular basis.
Clean or replace if necessary.

 **Work on the cooling system and the electrical system may only be performed by authorised personnel!**

Cleaning the condenser and evaporator

The unit housing must be open to perform work on these components; this work may only be performed by authorised service centres!

- ◇ Clean the condenser and the evaporator either by blowing air into the unit or with a vacuum cleaner or soft brush.
Do not expose it to a direct stream of water.
- ◇ Keep in mind that the fins are easy to damage or bend.
- ◇ Carefully clean the inner surfaces of the unit, the condensation tray with hose connection, the fan and the fan housing.
- ◇ Reassemble all of the disassembled parts properly.
- ◇ Perform a functional test and conduct an electrical safety check!



Import information on recycling!

The unit is operated with the environmentally-friendly refrigerant R134 a which does not harm the ozone layer. The refrigerant/oil mixture in the unit must be disposed of properly in accordance with general regulations and local requirements.

Troubleshooting

The unit was tested repeatedly during production to ensure that it is working properly.

However, should problems occur, refer to the following list.

The unit does not start:

- ◇ Check the connection to the power supply.
230V / 1~ / 50 Hz.
- ◇ Check the power fuse installed by the customer.
10 A.
- ◇ Check the power plug for damage.
- ◇ Check that the condensation tank has been inserted properly and is not full.
“Tank full” may not appear on the display.
- ◇ Check that the microswitch of the condensation tank is working.
- ◇ Check hygostat settings.
The humidity in the setup room must be more than the humidity of the selected range.

The unit starts but no condensation forms:

- ◇ Check the room temperature.
The operating range of the unit is between 6 °C and 32 °C.
- ◇ Check the humidity.
Minimum 40 % relative humidity.
- ◇ Check the air intake filter for dirt.
Clean or replace if necessary.
- ◇ Check the exchanger fins for dirt.
To conduct this test, the unit must be open; it may only be performed by an authorised service centre.

 **Before performing any work on the unit, make sure to unplug power cord.**

The unit is loud or vibrates, condensation comes out:

- ◇ Make sure that the unit is in an upright position on a flat surface.
- ◇ Check the condensation tray and the connection adapter for dirt.
To perform this test, the unit must be open; it may only be performed by an authorised service centre.

If, after performing these checks, the unit still does not work properly, please notify an authorised service centre.

 **Work on the cooling system and the electrical system may only be performed by authorised personnel!**

Technical Data

Series		ETF 240
Operating range temperature	°C	6-32
Operating range humidity	% r. h.	40-100
Dehumidification capacity max.	l/day	26
at 30 °C / 80 % r.h	l/day	24,4
Air capacity, max.	m³/h	190
Refrigerant	—	R 134a
Refrigerant amount	g	340
Electrical connection	V	1 ~ 230
Frequency	Hz	50
Rated current max.	A	3,4
Power consumption max.	kW	0,62
Fuse protection (supplied)	A	10
Sound pressure level L _{pA} 1m ¹⁾	dB(A)	43
Depth	mm	314
Width	mm	390
Height	mm	612
Weight	kg	21

1) Noise measurement DIN 45635 - 01 - KL 3

Wiring Diagram

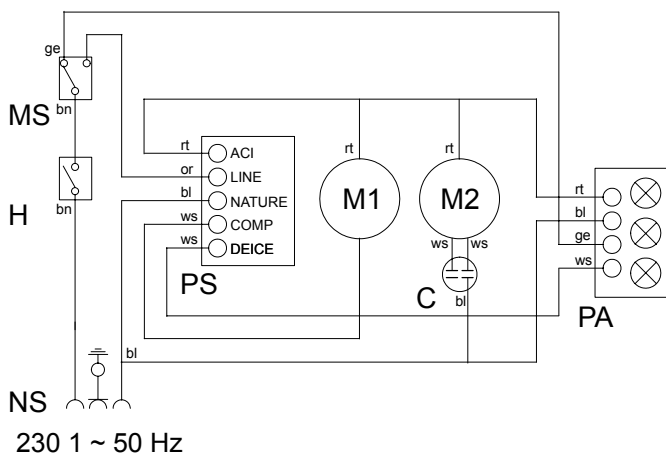

C	Condensator	MS	Microswitch
H	Hygrostat	NS	Power supply
M1	Compressor motor	PA	Display circuit board
M2	Fan motor	PS	PCB with control

Customer Service and Guarantee

For the guarantee to be valid, the purchaser or his customer must completely fill out the "guarantee certificate" enclosed with all units and send it back to REMKO GmbH & Co. KG.

The units are repeatedly tested at the production site to ensure that they are working properly. If a malfunction occurs that cannot be eliminated by the operating personnel, please contact your dealer or contact person.

Operation/handling which does not comply with these instructions is prohibited!
In cases of non-compliance, we assume no liability and the guarantee becomes null and void.

Proper Use

The units have been designed and equipped exclusively for dehumidification purposes.

The manufacturer assumes no liability for damage resulting from non-compliance with manufacturer specifications and legal requirements, or if modifications are made to the units.

Exploded View

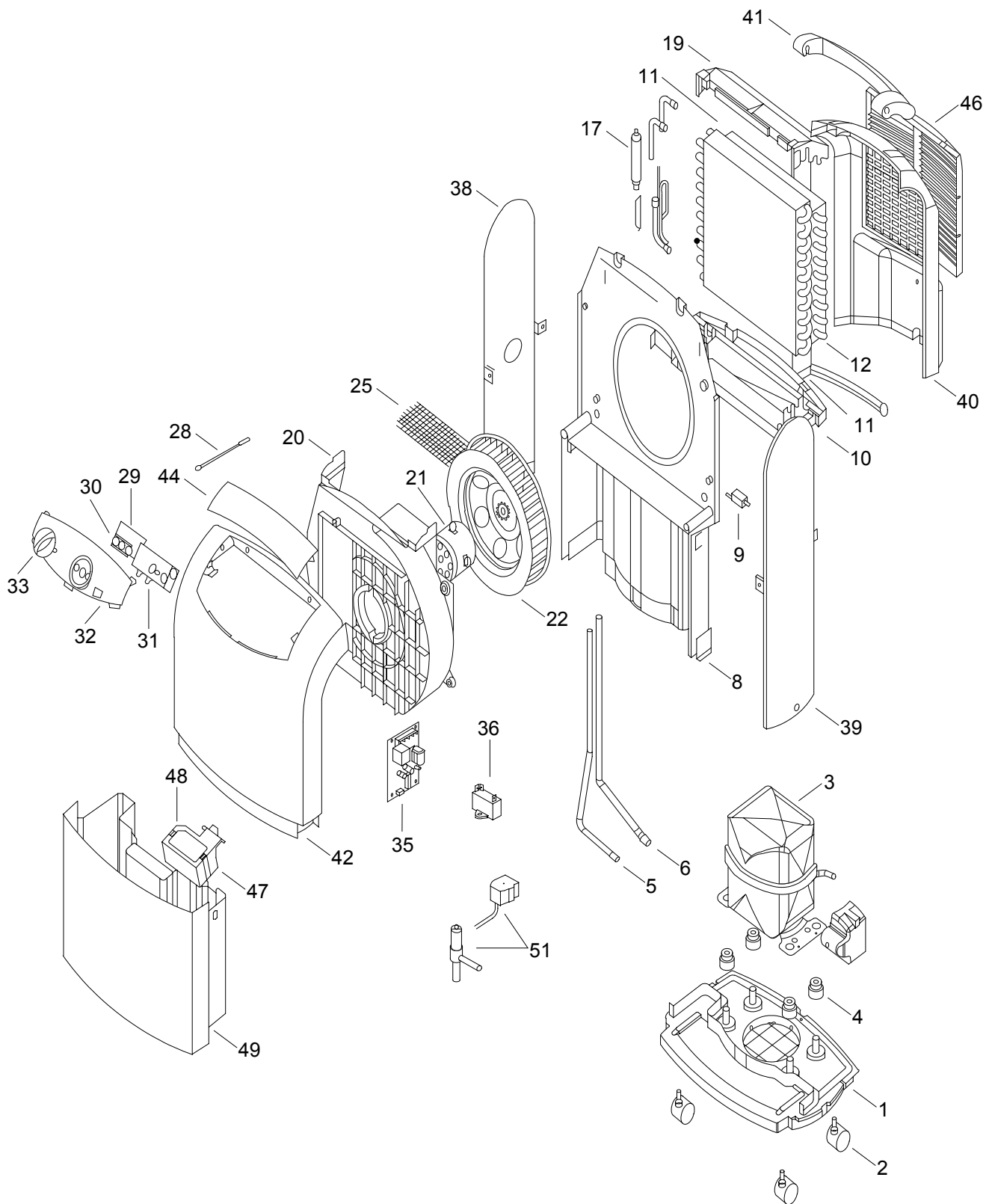

We reserve the right to make changes to dimensions and design in the interest of technical progress.

Spare Part List

No.	Description	Ref. No.
1	Base plate	1103620
2	Transport roller	1103621
3	Compressor	1103622
4	Vibration absorber	1103623
5	Suction pipe	1103624
6	High-pressure line	1103625
8	Center wall	1103626
9	Microswitch	1103627
10	Collection tray	1103628
11	Evaporator	1103630
12	Condenser	1103631
17	Dryer	1103632
19	Cover, top	1103633
20	Fan housing	1103634
21	Fan motor	1103661
22	Fan wheel	1103636
25	Protective grille	1103637
28	Anti-frost sensor	1103642
29	Circuit board, control lights	1103662
30	Cover, control lights	1103663
31	Hygrostat	1103664
32	Control panel	1103665
33	Rotating knob	1103666
35	PCB with control	1103667
36	Condensor	1103668
38	Side plate, right	1103649
39	Side plate, left	1103650
40	Rear wall	1103651
41	Transport handle	1103652
42	Front wall	1103653
44	Air directing flap	1103654
46	Air intake grill with filter	1103655
47	Float housing	1103656
48	Float, styrofoam	1103657
49	Condensation tank	1103658
51	Magnetic valve, cpl.	1103659
Not shown	Electrical cable incl. plug	1103660

When ordering spare parts please indicate ref. no. and machine no. (see type plate).

Maintenance and Service Log

Model:

Model No.:

	1	2	3	4	5	6	7	8	9	10	11	12	13	14	15	16	17	18	19	20
Clean device -surface-																				
Clean device -interior-																				
Clean condenser																				
Clean evaporator																				
Clean fan blade																				
Clean/replace dust filter																				
Check protection guards																				
Check device for damage																				
Check all fixing screws																				
Electric safety-inspections																				
Test run																				

Remarks:.....

1. Date:..... Signature	2. Date: Signature	3. Date: Signature	4. Date: Signature	5. Date:..... Signature
6. Date:..... Signature	7. Date: Signature	8. Date: Signature	9. Date: Signature	10. Date:..... Signature
11. Date:..... Signature	12. Date: Signature	13. Date: Signature	14. Date: Signature	15. Date:..... Signature
16. Date:..... Signature	17. Date: Signature	18. Date: Signature	19. Date: Signature	20. Date:..... Signature

The unit must be maintained according to legal regulations by authorised personnel only!

REMKO GmbH & Co. KG

Klima- und Wärmetechnik

32791 Lage, Im Seelenkamp 12

32777 Lage, PO Box 1827

Phone +49 5232 606-0

Fax +49 5232 606-260

E-mail info@remko.de

Internet www.remko.de