

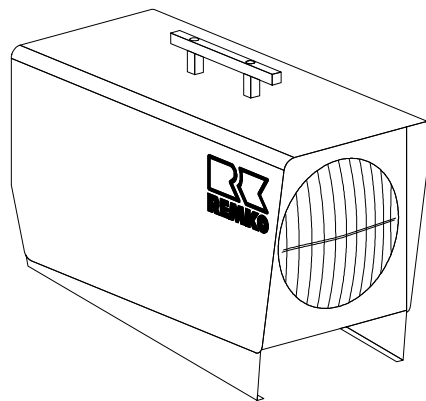

REMKO ELT Electric Heaters



**Operation
Technology
Spare Parts**

Operating instructions

Make sure to read these instructions carefully before starting/using the unit!

**Our guarantee will become void when the unit supplied by us is used and installed for inadequate purposes, or maintained incorrectly, etc., or if it is changed without our prior consent.
Subject to alterations!**

Mobile Electric Heaters

CE

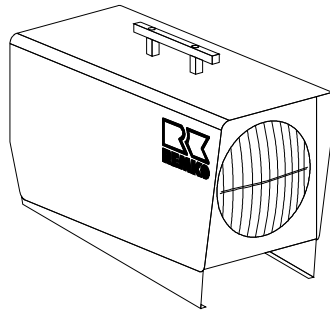

Contents	Page	Contents	Page
Safety Instructions	4	Exploded view ELT 3-2	7
Description of the unit	4	Spare part list ELT 3-2	7
Starting	4	Exploded view ELT 10-6	8
Unit shut down	5	Spare part list ELT 10-6	8
Maintenance	5	Exploded view ELT 18-9	9
Troubleshooting	6	Spare part list ELT 18-9	9
Service and guarantee	6	Wiring diagram	10
Technical data	6	Maintenance log	11



Always keep these operating instructions near or on the unit!



Safety Instructions

REMKO electric heaters will provide you with high utility and long life thanks to our extensive material, function and quality controls. Dangers may arise nevertheless if the unit is used by persons not familiar with its operation or if the unit is not used for its intended purpose.

The persons charged with the operation of the units have to check these before starting work as to visible defects of the operation and safety devices, as well as to make sure that no protective devices are missing. *In the case of faults the supervisor is to be informed.*

In the case of faults which endanger the safe operation of the units, the units are to be stopped!

During the operation of the units the applicable local regulations are to be observed and the relevant safety measures to be taken.

Make sure that the prescribed safety distances from combustible objects are observed!

A free air suction and air discharge must be ensured.

The blow off opening of the unit may not be narrowed or equipped with hoses or conduits.

Never place foreign objects into the unit.

Do not cover the units during operation.

The units may not be operated near bath tubs, showers, swimming pools, etc.

The units may not be operated directly beneath a wall socket.

The units may not be exposed to direct water jets.

Make sure that no water penetrates inside the units.

The units may not be operated in rooms which are endangered by explosions.

Protect all electric cables outside the units from damage (e.g. caused by animals).

 **Connecting cable extensions may be laid exclusively by authorised electricians based on the unit capacity, cable length and taking the local terms of use into account.**

Description of the Unit

The units are operating with electric energy and are suitable for a fully automatic, all-purpose and simple application.

The units are equipped with capsuled electrical heating elements, noiseless maintenance-free axial fans, safety and after-cooling thermostat, thermostat socket and connecting cable with plug.

The units are in accordance with the basic safety and health requirements of the relevant EC – regulation.

The units are handled simply and are safe in operation.

Application

Drying of new buildings, spot heating of working places outside or in fire-proof halls and production places.

Permanent or temporary heating of rooms.

Defrosting of machines vehicles and fire-proof storing goods with keeping the prescribed distance of safety.

Working of the unit

All units can be used for heating or ventilation by setting the equivalent mode on the operating switch.

The unit **ELT 3-2** has got exclusively on heating stage and has a 2 step operating switch.

The units **ELT 10-6** and **ELT 18-9** has got three heating stages.

The units can be operated with a room thermostat (accessories) which is ready to be plugged in, to ensure a constant room temperature. When the pre-selected temperature has been reached, the thermostat stops the heating operation to restart it when the temperature has fallen below the set value.

When the units have been switched off by the operating switch or the room thermostat, the supply air fan continues running for a certain time to cool down the heat exchanger, and then it stops automatically.

 **The electric connection of the units is to be carried out via a special supply point with fault current safety switch.**

Starting

A well trained person is to be charged with the operation and control of the units.

1. Check the main voltage is in accordance with the unit voltage.

ELT 3-2 230V/1~

ELT 10-6 and ELT 18-9 400V/3~

2. Put operating switch into position "0".

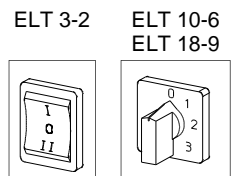

3. Connect the unit-plug to an adequate mains socket..

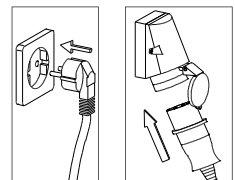

Switch settings

Operating switch
ELT 3-2

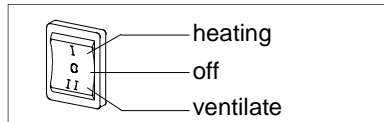

Operating switch
ELT 10-6
ELT 18-9

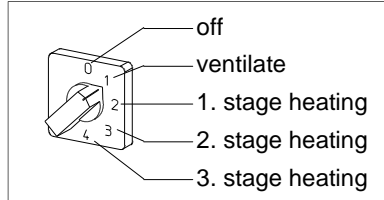

Ventilation

In this position only the supply air fan runs. The thermostat regulation and the heating operation is not possible.

1. Put the operating switch into the necessary position.

Heating without room thermostat

The unit runs under continuous duty.

1. Connect the supplied bridge circuit plug **2** to the thermostat socket **1** of the unit.
2. Put the operating switch into the desired position.

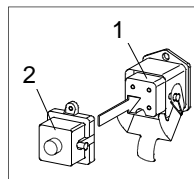

 **For optimum unit operation, the device should not be operated at an ambient temperature above 25 °C.**

Heating with room thermostat

The unit runs fully automatically and is dependent on set temperatures.

1. Remove the bridge circuit plug **2**.
2. Connect thermostat plug **3** of the room thermostat (accessories) to the thermostat socket **1**.
3. Put room thermostat **4** in a suitable place.
The thermostat sensor may not be exposed directly to the hot air current and not fixed directly on a cold surface.
4. Pre-select desired room temperature on the room thermostat.
5. Put the operating switch into the desired position.

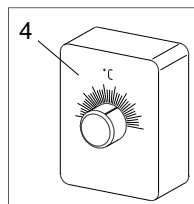
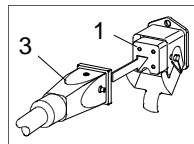

Unit Shut Down

ELT 3-2

ELT 10-6
ELT 18-9

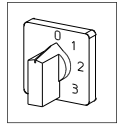
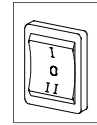

1. Put operating switch into position "0" (OFF).

Attention, important hints to the after-cooling phase.

The air supply fan continues running to cool down the unit and then stops later.

Fan can start several times before final switching off.

 **Never interrupt (except in emergency situations) the connection to the mains before the end of the whole after-cooling phase.**
Our guarantee does not cover damages caused to the unit by overheating.

Maintenance

Regular maintenance and the observation of some basic principles is important to ensure a long service life and a trouble-free operation of the unit.

 **Prior to starting any work make sure to pull the mains plug out of the mains socket!**

Please pay attention to the following points:

The unit is to be maintained and cleaned in regular intervals.

The unit is to be kept free from dust and other deposits and is to be cleaned only with a dry or humid cloth.

Do not use water jet.

Do not use any aggressive cleaning agents or those which are harmful or environmentally unfriendly.

Do not use cleaning agents which contain solvents.

Only use suitable cleaning agents to remove extreme dirt.

Check safety devices regularly.

Check protective suction and blower grids regularly and clean, when necessary.

Do not damage the sensor and capillary tube of the thermostat when the protective blower grid is installed or removed.

According to the terms of use the units are to be checked as to their perfect operation by an expert when necessary, but at least once a year.

 **Please carry out an electrical safety test after having finished service on the unit.**

Troubleshooting

 **Prior to starting any work make sure to pull the mains plug out of the mains socket! Setting and maintenance is to be carried out only by authorised experts!**

Unit (fan) does not start:

1. Check main fuse
2. Check connecting cable with plug
3. Check operating switch
4. Check slight drifting of fan (motor)

Unit does not heat

1. Check operating switch
2. Check auxiliary relay / contactor (ELT 10-6 / ELT 18-9).
3. Check function of temperature limiter resp. check capillary tubing (if damaged)
4. Check if thermostat plug resp. bridge circuit plug is coupled
5. Check thermostat-operation: thermostat must be set higher than the room temperature

Should the unit still not be working despite these checks, please contact an authorised service centre.

Service and Guarantee

Any claims under guarantee regarding materials can be accepted only when the orderer or his customer has filled in completely the "guarantee certificate" which is enclosed with every REMKO-heater and has returned it to REMKO GmbH & Co. KG in due time after the unit's sale and commissioning.

The units are factory tested on faultless function. If any failure occurs though which cannot be eliminated by the operating person, please contact your dealer or contact person.

 **An operation/use other than that indicated in these instructions is prohibited!**
In the case of non-observation we will not be held responsible and our guarantee will become void.

Correct usage

The units are to be used only for heating and ventilation purpose in industrial or commercial application because of their construction and equipment.

If specification of the manufacturer or legal regulations, are not followed or if unauthorised changes are made on the unit, the manufacturer is not liable for resulting damages.

Technical Data

Series		ELT 3-2	ELT 10-6	ELT 18-9	
Nominal heat output	kW	3,2	10,5	18	
Switchable heat output	kW	1 x 3,2	3 x 3,5	3 x 6	
Air output	m ³ /h	350	750	1000	
Electrical connection	V	230/1~	400/3~	400/3~	
Frequency	Hz	50	50	50	
Rated current	A	13,9	14,9	27,5	
Power consumption max.	kW	3,25	10,65	18,2	
Fuse protection (required)	A (inert)	16	16	32	
Sound pressure level L _{pA} 1m ¹⁾	dB (A)	46	53	57	
Dimensions	Length	mm	400	675	740
	Width	mm	200	300	335
	Height	mm	335	455	500
Weight	kg	6,8	20,0	27,4	

1) noise measuring DIN 45635 - 01 - KL 3

Exploded View ELT 3-2

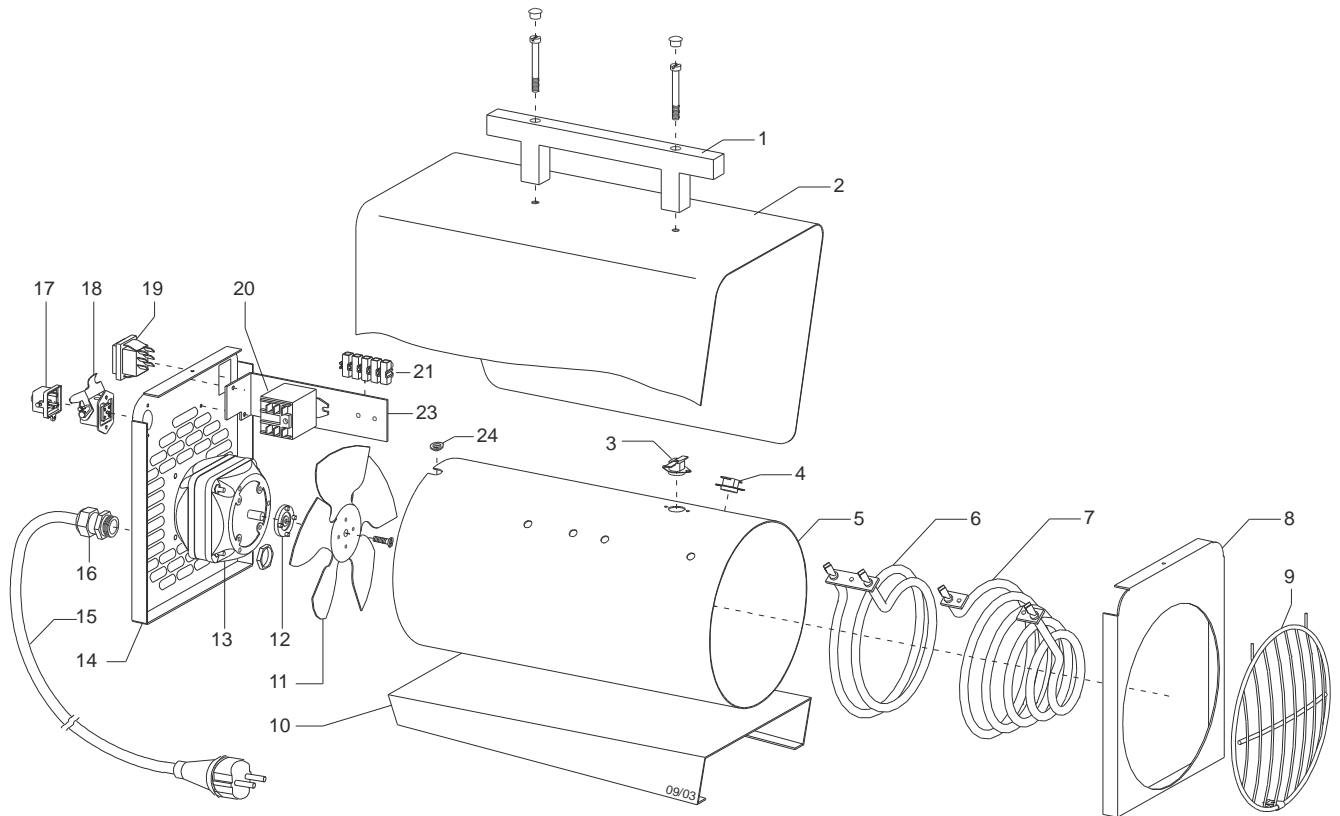

Spare Part List ELT 3-2

No.	Description	Ref.-No.
1	transport handle	1101142
2	outside casing	1103905
3	recool thermostat	1104065
4	temperature limiter	1101161
5	inside casing	1103907
6	heating element	1103908
7	heating element	1103909
8	front panel	1103910
9	discharge protection grille	1103803
10	base plate	1103911
11	fan blade	1103902
12	clutch plate	1103912
13	fan motor	1103820
14	rear panel	1103913
15	connecting cable with plug	1103901
16	traction relief	1101267
17	bridge circuit plug	1101019
18	thermostat socket, cpl.	1101018
19	operating switch, cpl.	1101188
20	contactor	1108038
21	terminal strip, 6 x	1101366
23	angle support	1101067
24	protection socket, small	1101304
not shown	thermostat plug	1101020

We reserve the right to make modifications in dimensions and construction in the interests of technical progress.

Exploded View ELT 10-6

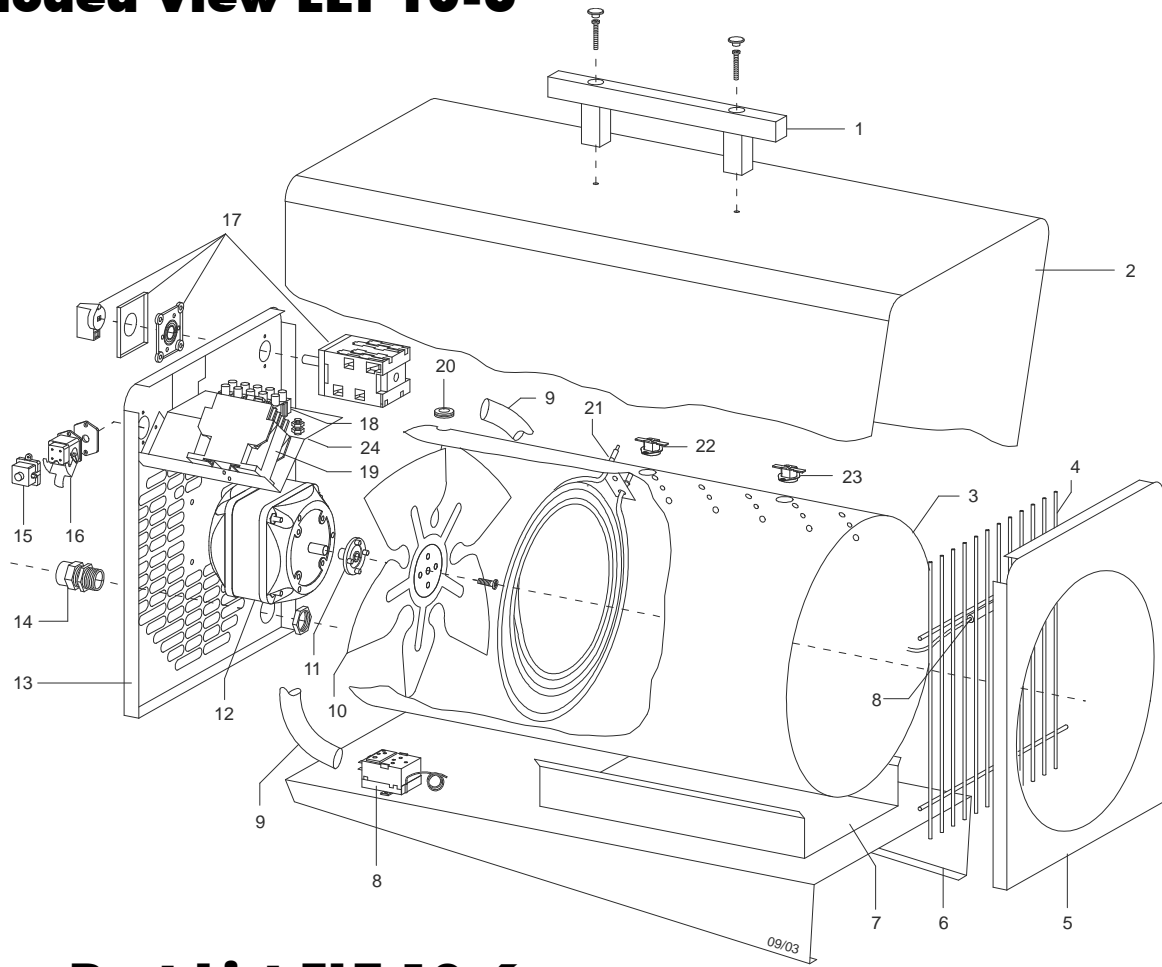

Spare Part List ELT 10-6

No.	Description	Ref.-No.
1	transport handle	1101142
2	outside casing	1107910
3	inside casing	1103951
4	discharge protection grille	1103952
5	front panel	1103953
6	base plate	1107913
7	support bracket	1107914
8	temperature limiter with sensor	1107960
9	protection hose	1107915
10	fan blade	1103950
11	clutch plate B8 \varnothing	1103956
12	fan motor	1101254
13	rear panel	1103954
14	traction relief	1107944
15	bridge circuit plug	1101019
16	thermostat socket, cpl.	1101018
17	operating switch, cpl.	1107993
18	terminal strip, 5 x	1107952
19	contactor	1101025
20	protection socket	1101304
21	heating element	1103955
22	temperature limiter	1101161
23	recool thermostat	1104065
24	angle support	1101031
not shown	connecting cable with plug	1101026
	thermostat plug	1101020

We reserve the right to make modifications in dimensions and construction in the interests of technical progress.

Exploded View ELT 18-9

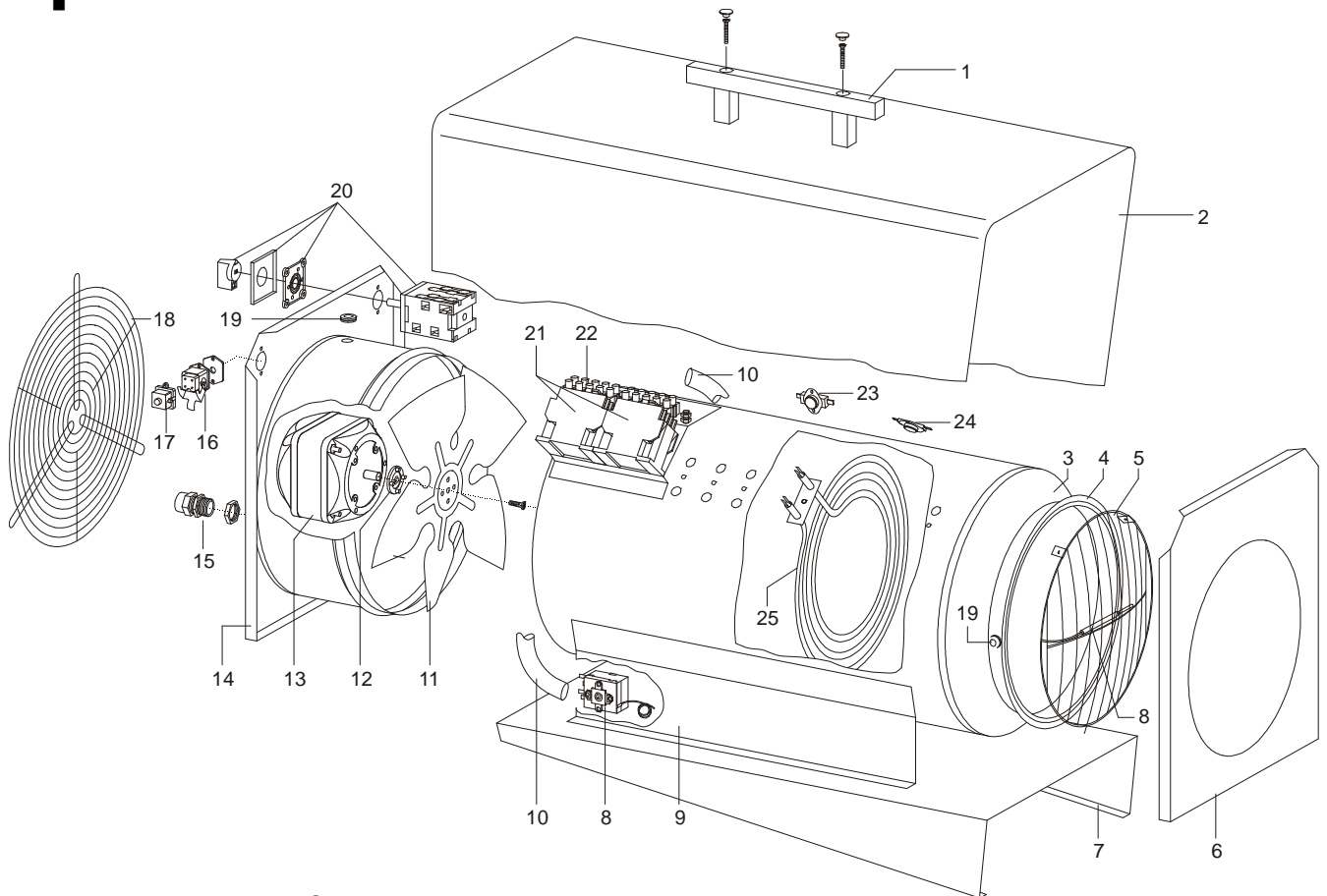

Spare Part List ELT 18-9

No.	Description	Ref.-No.
1	transport handle	1101142
2	outside casing	1107920
4	cone gasket	1107954
3	inside casing with blow-out cone	1107953
5	discharge protection grille	1101353
6	front panel	1107921
7	base plate	1107950
8	temperature limiter with sensor	1107960
9	support bracket	1107922
10	protection hose	1107915
11	fan blade	1101153
12	clutch plate B8 Ø	1103956
13	fan motor	1101254
14	rear panel	1107923
15	traction relief	1107961
16	thermostat socket, cpl.	1101018
17	bridge circuit plug	1101019
18	air suction grille	1107947
19	protection socket	1101304
20	operating switch, cpl.	1107993
21	contactor	1101021
22	terminal strip, 5 x	1107952
23	temperature limiter	1101161
24	recool thermostat	1104065
25	heating element	1107998
not shown	connecting cable with plug	1107962
	thermostat plug	1101020

We reserve the right to make modifications in dimensions and construction in the interests of technical progress.

Wiring Diagram

ELT 3-2

230 V / 1~, N, PE / 50 Hz

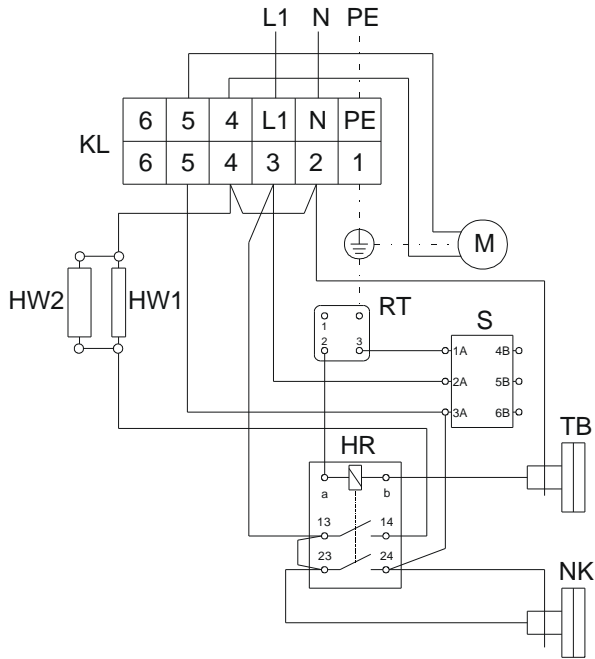

ELT 10-6

400 V / 3~, N, PE / 50 Hz

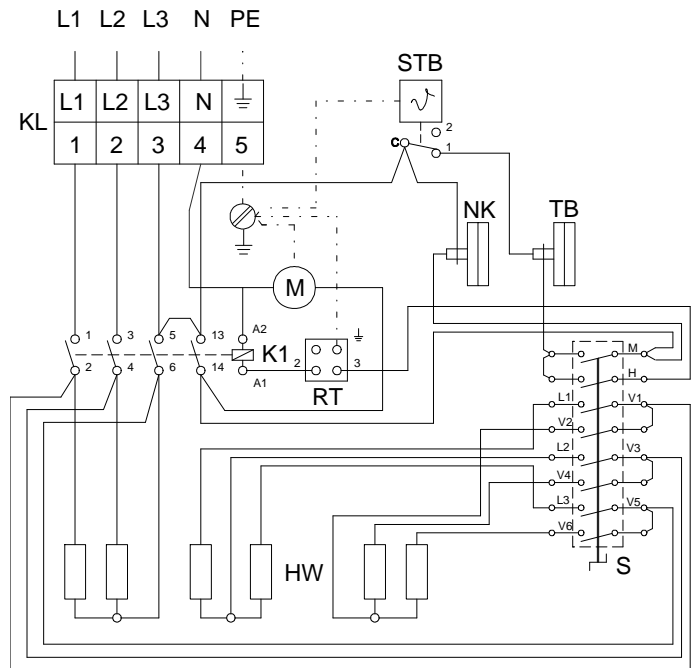

- | | | |
|----------------------|------------------------|---|
| HR = contactor | KL = terminal strip | S = operating switch |
| HW = heating element | M = fanmotor | STB = temperature limiter (with sensor) |
| K1 = contactor 1 | NK = recool thermostat | TB = temperature limiter |
| K2 = contactor 2 | RT = thermostat socket | |

ELT 18-9

400 V / 3~, N, PE / 50 Hz

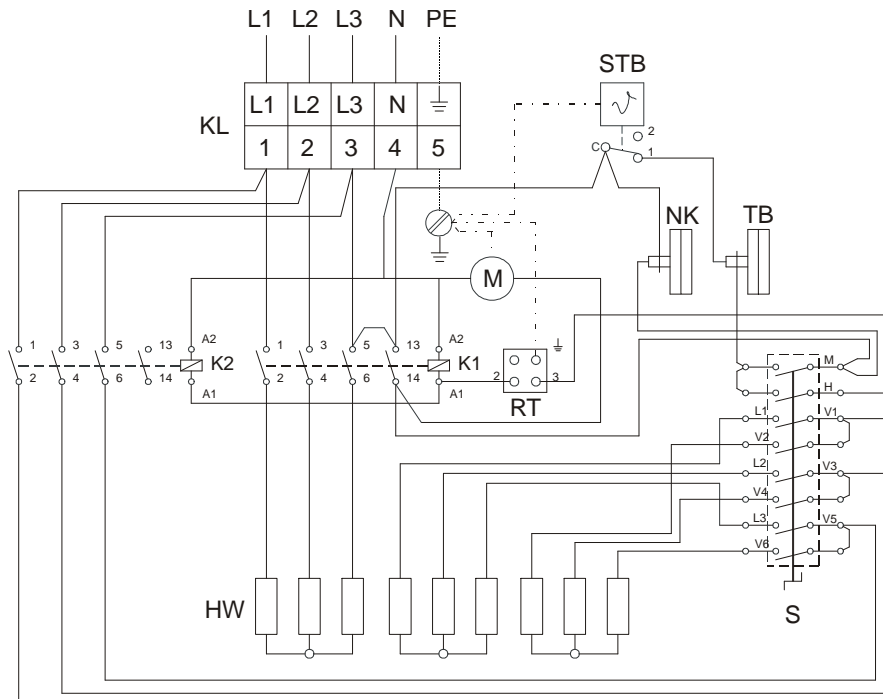

We reserve the right to make modifications in dimensions and construction in the interests of technical progress.

Maintenance Log

Model:

Model No:

	1	2	3	4	5	6	7	8	9	10	11	12	13	14	15	16	17	18	19	20
Clean unit -surface-																				
Clean unit -interior-																				
Clean protection grille																				
Clean fan blade																				
Check safety facility																				
Check protection guards																				
Check unit for damage																				
Check fastening screws																				
Test run																				
Electric safety-inspections																				

Remarks:.....

1. Date:..... Signature	2. Date: Signature	3. Date: Signature	4. Date: Signature	5. Date:..... Signature
6. Date:..... Signature	7. Date: Signature	8. Date: Signature	9. Date: Signature	10. Date:..... Signature
11. Date:..... Signature	12. Date: Signature	13. Date: Signature	14. Date: Signature	15. Date:..... Signature
16. Date:..... Signature	17. Date: Signature	18. Date: Signature	19. Date: Signature	20. Date:..... Signature

Setting and maintenance work is to be carried out only by authorised specialists!

REMKO GmbH & Co. KG

Klima- und Wärmetechnik

D-32791 Lage • Im Seelenkamp 12

D-32777 Lage • PO Box 1827

Phone +49 5232 606 - 0

Fax +49 5232 606 260

E-Mail info@remko.de

Internet www.remko.de