

REMKO PWW 6000

Warm Water Vario Heating Units

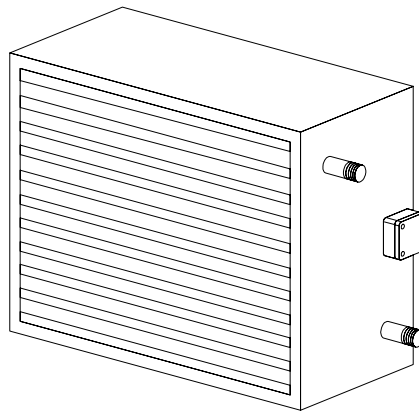

Operation
Technology
Spare Parts

Operating Instructions

Read these instructions carefully before setting up/operating the unit!

Our guarantee becomes null and void if the unit is used, set up or maintained improperly,
or if modifications are made to the supplied unit without our prior consent.

Subject to alterations!

Warm Water Wall-Mounted Heating Units REMKO PWW 6000

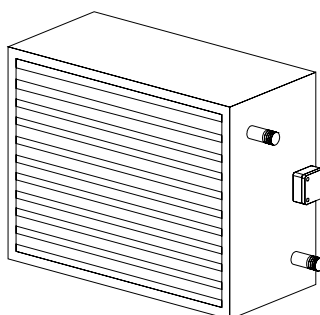

Contents	Page	Contents	Page
Safety Instructions	4	Service and Care	8
Assembly Instructions	4	Maintenance	8
Unit Assembly	5	Technical Data	9
Sample Assemblies	6	Customer Service and Guarantee	9
Electrical Connection	7	Accessories	10
Initial Operation	7	Switching Units	12
Shutting Down the Unit	8		



Always keep these operating instructions near or on the unit!



Safety Instructions

Extensive tests have been conducted on the material, functionality and quality of the units.

Hazards may nevertheless arise if the unit is used by persons not familiar with its operation or if the unit is not used for its intended purpose.

Please make sure to always comply with these safety instructions:

- ◇ The relevant local building codes must be observed!
- ◇ The operator is responsible for proper unit assembly, correct electrical installation and safe operation of the units.
- ◇ The units must be set up, mounted and operated in such a way that employees are not bothered by or put at risk of radiant heat.
- ◇ The units may only be attached to sturdy constructions or ceilings made of materials with adequate bearing capacity.
- ◇ The units must be attached with sturdy wall mounts that are fastened to the unit.
- ◇ Assembly, connection of the heating medium, connection of the electrical system and maintenance may only be performed by trained and authorised personnel.
- ◇ The units may not be set up, assembled or operated in surroundings susceptible to fire or explosions.
- ◇ The units must be set up outside of high-traffic zones, e.g. also cranes.
A safety zone of 1 m must be maintained.
- ◇ The units may only be operated when mounted.
- ◇ Safety components such as, for example, protective grilles, may not be disassembled or taken out of operation.
- ◇ The units may only be used for their intended purpose within the specified operating ranges and with approved transport media.
See type plate.
- ◇ The air intake grille must always be kept free of dirt and loose objects; the unit outlets may not be blocked.
- ◇ Never insert foreign objects into the unit.
- ◇ The units may not be exposed to a direct stream of water.
- ◇ Never let water get inside the units.
- ◇ All of the unit's electrical lines must be protected from damage, e.g. by animals.

 **The units are only ensured to function properly if the initial temperature in the unit supply lines and the pump capacity are adequate for the selected class of unit.**

Assembly Instructions

Follow these instructions to ensure that the units are assembled safely and effectively:

- ◇ The units are to be placed in such a way that areas where people work and spend time are not in the direct air current.
- ◇ The units may only be mounted on ceilings or roof constructions with adequate bearing capacity.
- ◇ The heat-exchanger must be connected in such a way that vibrations from the unit may not be transferred to the piping systems or vice-versa.
- ◇ For wall-mounting, a minimum height of 2.5 m to the lower edge of the unit must be observed.
- ◇ For wall assembly above 4 m, air should be circulated from the floor to ensure that heat is distributed evenly.
- ◇ For wall assembly below 4 m, the unit should be equipped with an air outlet hood HG 4.
- ◇ For wall assembly above 4 m, the unit should be equipped with a ceiling air outlet nozzle AD.
- ◇ Before connecting the unit to an existing warm water heating system, the boiler and pump must be checked for adequate capacity.
- ◇ For maintenance and repairs, we recommend attaching a repair switch close to the unit.
- ◇ After all attachment screws have been tightened evenly, the fan is to be checked to ensure that it is running smoothly.
- ◇ Units that operate with fresh air must be outfitted with frost protection monitors.

Electrical installation

The electrical connections of the units must be installed by authorised personnel in line with the relevant regulations and with the wiring diagrams.

Connection to the heating system

Before connecting to the customer heating system, the heating and pump capacity must be checked to ensure that they meet the technical requirements of the respective unit.

The REMKO PWW unit should be connected via shut-off valve, automatic dehumidifier and screw attachments in the supply and return lines.

 **When connecting the screw attachments of the heating medium connection, a suitable tool should be used to apply counter-pressure to prevent damage caused by turning the connection lines.**

Unit Assembly

Brackets

Brackets for wall and ceiling assembly (2 per unit) are inserted into the openings at the back of the unit and attached with the supplied screws.

Components that are attached directly to the units, such as mixed-air boxes or filter boxes, are equipped with a bracket adapter.

When using customer-installed bracket constructions, the minimum distance to the wall (dimension "e") must be observed!

KO bracket

For wall and ceiling assembly

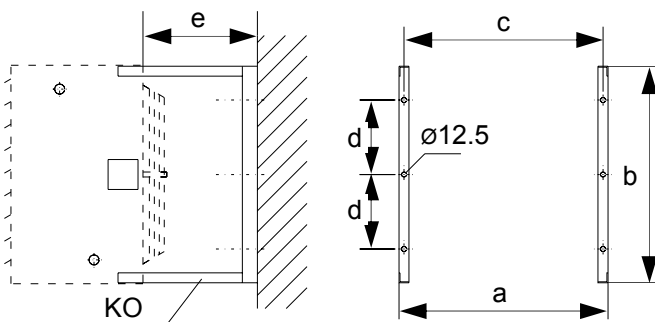

Dimension PWW	a	b	c	d	e
6030-3 / 4	562	432	512	155	270
6050-3 / 4	642	507	592	192	270
6080-3 / 4	802	622	752	250	270
6100-3 / 4	882	732	832	305	340

The brackets must be current-free and screwed on to the unit and the wall/ceiling.

Cu / Al heat-exchangers

The heat-exchangers are made of copper pipes with aluminium plate fins pressed onto the outside. The plate fin package is surrounded by a galvanized, zinc-plated steel frame.

The collector and the distributor are made of steel.

Please observe the following for the heat-exchangers:

- ◇ The heating medium connection is made via threaded connectors.
- ◇ The maximum operating temperature is 130 °C.
- ◇ The maximum operating pressure is 16 bar.
- ◇ The heat-exchangers are not suitable for operation with steam or thermal oil.

Connection to the heating system

- ◇ The REMKO PWW is to be connected by the customer via the shut-off valve, automatic dehumidifier and screws in the supply and return lines.
Use compensators if necessary.
- ◇ It does not matter which side is connected.
Right or left.
- ◇ The units operate on the principle of counter-current.
- ◇ The water (supply line) usually **comes in** at the bottom. The water usually **goes out** (return line) at the top.

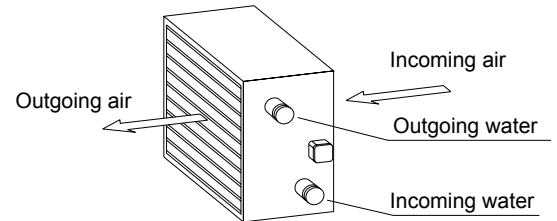

- ◇ After assembly, the heat-exchanger must be carefully dehumidified.
Air pockets in the register reduce the unit performance.
- ◇ You can find the thread sizes of the heat register in the technical data.

When the fan is idle, the heating medium supply must be interrupted.

Draining in case of frost

It is not possible to statically drain the heat-exchanger completely. The heat-exchanger can only be completely drained when compressed air is used.

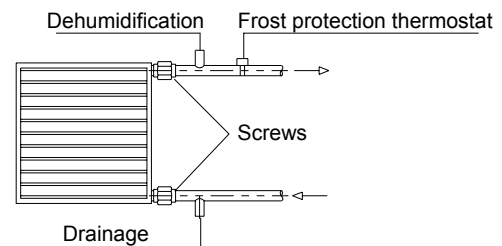

Important information about frost protection!

To prevent frost damage, a frost protection mechanism must be attached for temperatures below 0 °C.

There may not be any water in the heat-exchanger for systems taken out of operation in rooms susceptible to frost. The remaining water must be blown out with compressed air.

If this is not possible, the heating medium (water) must be mixed with a suitable anti-freeze.

No guarantee claims can be made for frost damage on the heat-exchanger!

Sample Assemblies

Circulation / Fresh air mode via the outside wall

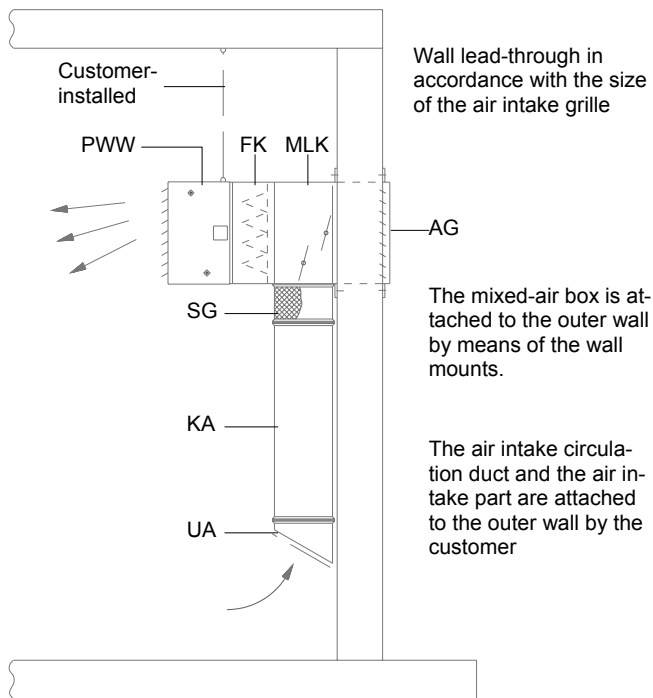

- AG = Outside air intake grille
- KA = Duct separator
- SG = Elastic lines
- MLK = Mixed-air box
- FK = Filter box for mixed-air box
- UA = Air intake piece for circulation

Ceiling assembly

In circulation mode with FK filter and KO bracket

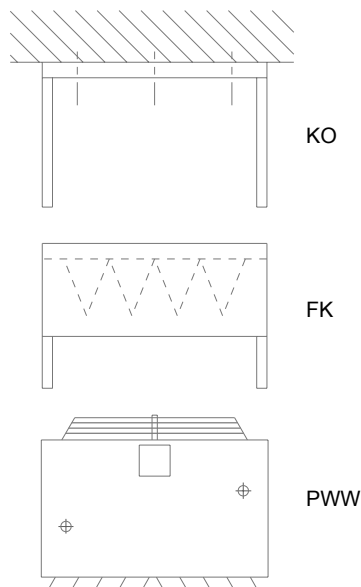

Circulation / Fresh air mode via the roof

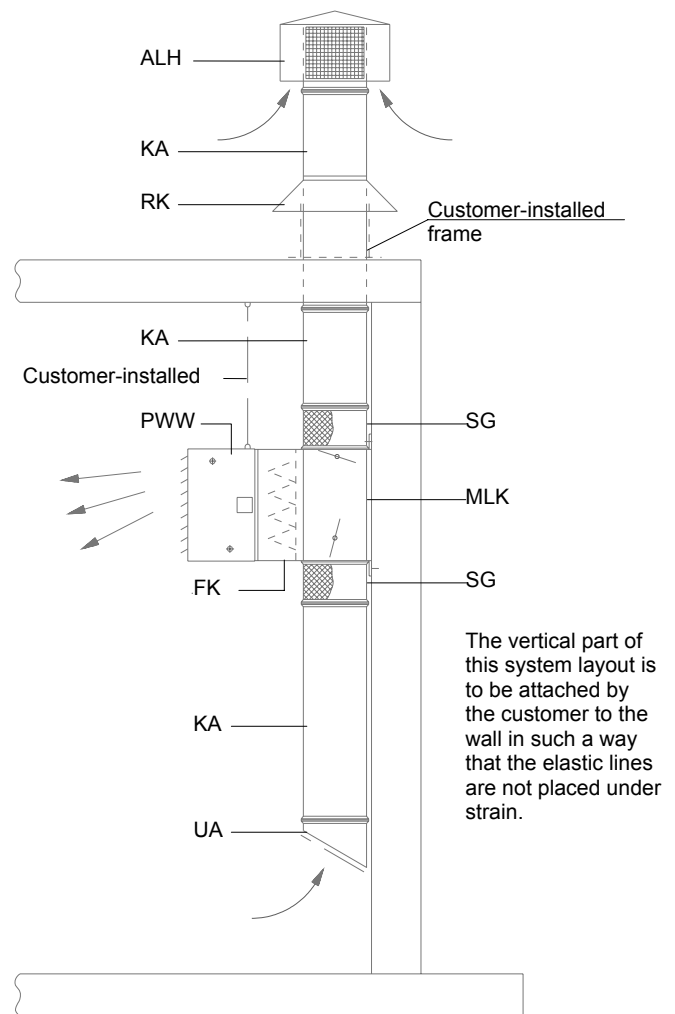

- AG = Outside air intake grille
- KA = Duct separator
- SG = Elastic lines
- MLK = Mixed-air box
- RK = Rain cover with duct part
- ALH = Air intake cover for the outside air
- FK = Filter box for mixed-air box
- UA = Air intake part for circulation

Wall assembly

In circulation mode with FK filter and KO bracket

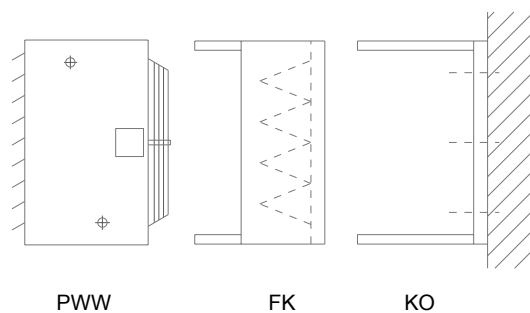

Electric Connection

The requirements of the local energy supply company as well as installation requirements specific for each unit must be observed.

 **The electrical connection may only be made by trained and authorised personnel.**

Restriction of guarantee!

Non-compliance with the relative legal requirements, operating instructions and unit-specific wiring diagrams can lead to malfunctions that cause damage.
In cases of non-compliance, the guarantee becomes null and void!

Connecting the units

Standard REMKO PWW models are equipped with axial fans that have external rotary current motors for a voltage of 400 V / 3~ / 50 Hz.

Switching the two speeds of the rotary current motor is done with a Y / Δ switch.

Integrated thermal contacts protect the motor. They switch off the fan motor at a winding temperature of 130 °C in connection with a suitable switching device (accessory).

The rotary current motors are connected to the corresponding switching units in accordance with the respective electrical wiring diagrams.

Connecting several units

If necessary, several units (even of different sizes) can be operated at the same time via a switching unit (accessory).

The overall capacity of the connected units may not, however, exceed the maximum electrical capacity of the corresponding switching unit.

For thermal motor protection, the thermal contacts of all motors are to be connected in a row. Follow the separate wiring diagrams.

There can never be more than one external regulating mechanism per switching unit (thermostat, day/night regulator, etc.) connected at a single time!

Terminal boxes on the unit

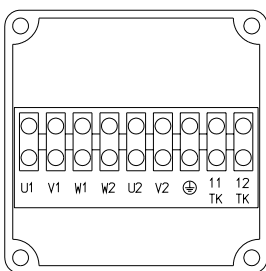

The corresponding power fuse in the power supply line to the switching unit must comply with the valid requirements.

The connections in the terminal box are to be connected with the corresponding switching unit (accessory).

Initial Operation

Prior to initial operation

1. Check that assembly is mechanically sound.
2. Check that the connection to the customer-installed heating system is correct.
3. Make sure that hot surfaces are protected against unintentional contact.
4. Ensure that the unit's electrical wiring has been made in accordance with the relevant guidelines and standards and complies with the enclosed wiring diagrams.
5. Check the fan area as well as the air intake and outlet area for foreign objects.
6. Make sure that all air outlet openings are opened.
7. Ensure that the distance between the fan wheel and housing is the same all the way around.
8. Activate the power supply to the switching unit and switch the unit on via the control switch.
9. Check to make sure that the fan is rotating in the direction of the arrow.
The rotational direction can be changed by reversing the 2 phases.
10. Remember that when using speed control, the capacity of the regulating unit must be adjusted to the capacity of the motor.
11. Initial operation is prohibited until it is ensured that the proper assembly and electrical installation corresponds to the provisions of the EU guidelines 89/392/EWG and 73/23/EWG.

During initial operation

All regulating, control and safety mechanisms must be checked to ensure that they are functioning properly and set correctly during initial operation.

1. Measure the power consumption of the fan.
The rated current may not exceed the value specified on the type plate in each switching phase.
2. Check the control/regulating function of the fan.
3. Check the motor protection function of the fan.
4. Check the function of the frost protection mechanism and the room thermostat
If mounted.
5. Check that the fan is running quietly.
6. Check the entire system for any vibrations.
7. Check that the heating medium supply lines have been properly connected and are impermeable.

 **The control switch must always be reset to "0" to restart the unit after the switching unit is separated from the power supply, following a power outage or a malfunction.**

Shutting Down the Unit

Prior to longer periods of non-operation

- ◇ Switch all poles of the electrical connections off.
- ◇ If there is a danger of frost, drain the system if the heating medium (water) has not been mixed with a suitable anti-freeze.

 **It is only possible to completely drain the heat-exchanger with compressed air.**

Service and Care

REMKO PWW units require virtually no maintenance when operated normally. They should, however, be checked regularly and, if necessary, cleaned, to ensure proper operation.

Important precautions prior to maintenance work

Perform the following steps prior to all service work:

1. Separate all poles of the unit from the power supply and secure it from being switched on by unauthorised persons.
It is not adequate to switch the unit off via the control switch on the switching unit!
2. Wait until the fan stops.
3. Turn off the flow of water and secure it from being opened by unauthorised persons.
4. Wait until the heat-exchanger has cooled down.

 **Do not flood the motor and the housing. Do not damage or bend the fan blades or plate fins.**

Cleaning materials

- ◇ Only clean the unit when dry or with a slightly moist towel and a soap solution.
- ◇ Never use high-pressure or steam cleaners.
- ◇ Do not use abrasive cleaners or cleaners that contain solvent.
- ◇ Even when the unit is extremely dirty, only use suitable cleaning materials.

General care

- ◇ Keep the inside and outside of the unit free of dust and other deposits.
- ◇ Keep the air intake and outlet openings from being blocked.
- ◇ Check the protection grilles and the heat-exchanger at regular intervals for dirt.
- ◇ Inspect any mounted filters.
Clean or exchange if necessary.

Cleaning the unit

1. Clean the air intake openings and the air outlet plate fins.
2. Clean the fan blades.
If necessary, dismantle the motor or protective grille beforehand.
3. Clean the fins of the heat-exchanger either by blowing air out or in, or with a soft brush.
4. Remove extreme dirt on the fan and plate fins with a soap solution.

Maintenance

Replacing the fan

1. Disconnect the electrical connection of the motor.
2. Remove the protective grille with the fan from the unit housing.
3. Remove the fan from the protective grille.
4. Mount the new fan on the protective grille.
5. Reattach the protective grill with the fan to the unit housing.
6. Reconnect the motor.

Replacing the heat-exchanger

1. Disconnect the electrical connection of the motor.
2. Drain the heat-exchanger and disconnect the heating medium connections.
3. Remove the accessories on the air intake and outlet sides and take the unit out of the bracket (mount).
4. Remove the rear wall with the fan.
5. Loosen the attachment screws of the heat-exchanger and take out the heat-exchanger on the air intake side.
6. Insert the new heat-exchanger and reassemble the unit in the reverse order.
7. Reconnect the motor.

Inspection following maintenance:

- ◇ The fan wheel must be able to rotate freely in the fan housing.
- ◇ The distance between the fan blades and the fan housing must be the same.
- ◇ The motor must rotate in the direction of the arrow.
- ◇ After service and maintenance is complete, an electrical safety test must be conducted in accordance with VDE 0701.

Technical Data

Type		BG 30 - 2	BG 30 - 3	BG 30 - 4	BG 50 - 2	BG 50 - 3	BG 50 - 4
Electrical connection	V	400/3N~	400/3N~	400/3N~	400/3N~	400/3N~	400/3N~
Frequency	Hz	50	50	50	50	50	50
Power consumption	kW	0.13/0.10	0.13/0.10	0.13/0.10	0.26/0.18	0.26/0.18	0.26/0.18
Rated current	A	0.26/0.16	0.26/0.16	0.26/0.16	0.52/0.29	0.52/0.29	0.52/0.29
Speed	U/min	1340/1040	1340/1040	1340/1040	1360/1020	1360/1020	1360/1020
Air capacity	m³/h	2250/1850	2050/1640	1850/1500	3800/3180	3400/2870	3150/2770
Sound pressure level ¹⁾	dB(A)	52/46	53/48	55/49	55/50	55/51	58/54
Heating medium connection	inch	R¾"	R1"	R1¼"	R¾"	R1"	R1¼"
Heating medium		Pump warm water or pump hot water up to max. 130 °C					
Operating pressure	bar	16	16	16	16	16	16
Weight	kg	24	26	27	31	34	36

Type		BG 80 - 2	BG 80 - 3	BG 80 - 4	BG 100 - 2	BG 100 - 3	BG 100 - 4
Electrical connection	V	400/3N~	400/3N~	400/3N~	400/3N~	400/3N~	400/3N~
Frequency	Hz	50	50	50	50	50	50
Power consumption	kW	0.42/0.28	0.42/0.28	0.42/0.28	0.76/0.47	0.76/0.47	0.76/0.47
Rated current	A	0.76/0.46	0.76/0.46	0.76/0.46	1.50/0.81	1.50/0.81	1.50/0.81
Speed	U/min	880/670	880/670	880/670	870/650	870/650	870/650
Air capacity	m³/h	5800/4400	5400/4300	4730/3700	9050/7400	8250/6620	7670/6180
Sound pressure level ¹⁾	dB(A)	55/49	55/49	55/49	58/54	58/54	59/55
Heating medium connection	inch	R1"	R1¼"	R1¼"	R1¼"	R1½"	R1½"
Heating medium		Pump warm water or pump hot water up to max. 130 °C					
Operating pressure	bar	16	16	16	16	16	16
Weight	kg	44	47	51	58	60	68

1) Measurement at intervals of 5 m, measuring room volume 800 m³, average reverberation time 1.4 s

Customer Service and Guarantee

For the guarantee to be valid, the purchaser or his customer must completely fill out the "**guarantee certificate**" enclosed with all units and send it back to REMKO GmbH & Co. KG.

The units are repeatedly tested at the production site to ensure that they are working properly. If a malfunction occurs that cannot be eliminated by the operating personnel, please contact your dealer or contract partner.

Proper use

The units are designed exclusively for industrial and commercial heating and insulation purposes on the basis of their design and equipment.

The manufacturer assumes no liability for damage resulting from non-compliance with manufacturer specifications and legal requirements, or if modifications are made to the units.



Operation/handling which does not comply with these instructions is prohibited!
In cases of non-compliance, we assume no liability and the guarantee becomes null and void.

Accessories

The units are outfitted at the factory with horizontal air outlet flaps.

The individually adjustable fins allow the flow of warm air to be aimed in two directions.



Air outlet accessories

Air outlet flap B (horizontal/vertical)

Installing the flap allows air to be directed across longer distances. The vertical and horizontal arrangement of the fins make it possible to direct the air in up to 4 directions

When retrofitting, the fins of the existing air outlet flap must be removed.

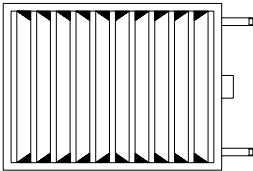

HG 4 air outlet cover

This air outlet cover makes it possible for air to be distributed evenly in 4 directions when the unit is mounted at a low level.

The air outlet cover may not be used at mounting heights of more than 5.0 m.

When retrofitting, the fins of the existing air outlet flap must be removed.

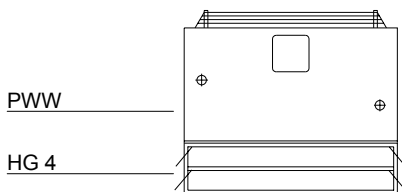

AD ceiling air outlet nozzle

The ceiling air outlet nozzle makes it possible to concentrate the warm air flow and is used at higher assembly heights and in larger halls.

When retrofitting, the fins of the existing air outlet flap must be removed.

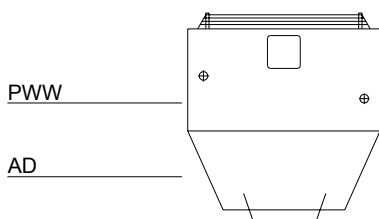

Air intake accessories

FK filter box

The filter box with pocket filter is designed for direct attachment to the unit.

The pocket filter is pulled out on the side.

The filter medium of the pocket filter can be regenerated and corresponds to the filter class EU 3.

Maintenance of the pocket filter

Depending on the operating conditions, the pocket filter must be checked at regular intervals and, if necessary, cleaned or replaced.

EF replacement pocket filters for the units:

PWW 4030	Ref. No. 1686253
PWW 4050	Ref. No. 1686254
PWW 4080	Ref. No. 1686255
PWW 4100	Ref. No. 1686256

Information about the FK filter box

How dirty the pocket filter is can be monitored via a differential pressure switch (special accessory).

When the final pressure differential is reached, the pocket filters must be replaced by new filters in the same class.

MLK mixed-air box

The MLK mixed-air box is designed to be mounted on the wall or the ceiling.

The ratio of outside air to circulation air can be set manually with the mixed-air flaps in gradual stages or with a flap adjustment motor (accessory).

Maintenance of the mixed-air box

When operating the mixed-air box with a flap adjustment motor, the mixed-air flaps must be checked at regular intervals for dirt and to ensure that they are functioning properly.

Frost protection mechanism

The frost protection thermostat is a precise water temperature regulator that can also be retrofitted to the surface of the pipe connections.

The supplied tension strap with clamps makes it possible to assemble it at a later time without having to drain the heating system.

The thermostat is equipped with a precision snap-action switch.

Installation

Prior to assembly, the pipe insulation in the area where the sensor is to be installed must be removed. The parts necessary for assembly such as tension strap, clamps, etc., are supplied with the unit.

Wiring diagram

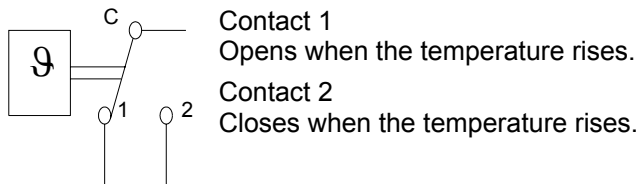

Technical data:

Adjustment range 25 to 95 °C, switching differential adjustable.

Maximum ambient temperature 70° C.

Adjustment motor open / closed

The adjustment motor is mounted directly on the flat axis. It is equipped with a universal terminal block and is fastened into place with a locking piston supplied with the unit.

The drive has a mechanism protecting it from overloading and requires no final switch. For manual operation, the transmission can be automatically disengaged using the automatic reset knob.

Wiring diagram

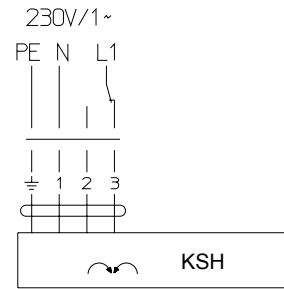

Technical data:

Adjustment motor Type KSH protected against overloading.

Capacity 10 W, 230 volt, 50 Hz.

Protection type IP 54, running time approx. 180 seconds

Maximum ambient temperature 55° C.

Adjustable adjustment motor

The adjustment motor is supplied directly with 230 volts of power. The transformer converts the power into extra low voltage of 24 volts. The motor is controlled depending on the input current and the position of the return potentiometers.

With the switch A /B, the polarity to the motor and at the same time to the return potentiometer is reversed. The rotational direction of the motor changes when the polarity is reversed.

A rotational spooling instrument can be connected between clamps (1) + and (4) to display the flap position.

Data of the instrument 0 to 100 µA, Ri max. 2500 Ω.

A voltage of 9.0 V at a max. current of 10 mA can be connected between clamps (1) + and (3).

Wiring diagram

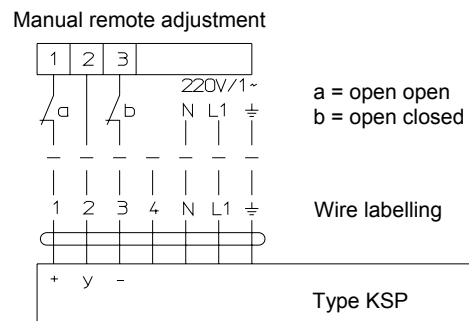

Technical data:

Adjustment motor Type KSP protected against overloading.

Capacity 5 W, 230 volt, 50 Hz.

Protection type IP 54, running time approx. 180 seconds.

Maximum ambient temperature 55° C.

SW 2 - 380 DI switching unit

Rotary current 400 volt, fan 2-speed maximum electrical capacity 4 kW

Wall-mounted, motor protected by integrated thermal contacts in the fan motor.

Design

Plastic housing, protection type IP 41,

Protective insulation in accordance with VDE, front plate with symbols for switching positions, power input and protective conductor terminals, main contactor, control switch with the functions "Off / Speed 1 / Speed 2", control fuse, operating light (goes out when there is a fan malfunction and/or **power interruption** to the switching unit), reset button, terminals for the motor output, connection terminals for the thermal contacts and room thermostat.

Switching on again after a problem

Each time the power supply is interrupted or the fan malfunctions, the fan reset button has to be pressed once!

Group switching

The switching unit is suitable for group switching. Several motors wired the same way can be connected to one switching unit.

The total capacity of the connected motors may not exceed the permissible switch capacity of the switching unit. The thermal contacts of all motors are to be connected in a row.

Important information about safe operation

Grounding and earthing or protective wiring and fuse protection must be done by the customer in accordance with the requirements of the VDE as well as the responsible EVU.

The electrical unit connections must be performed by authorised personnel in the line with the valid requirements in compliance with local laws and in accordance with the wiring diagrams.

Switching and wiring diagram

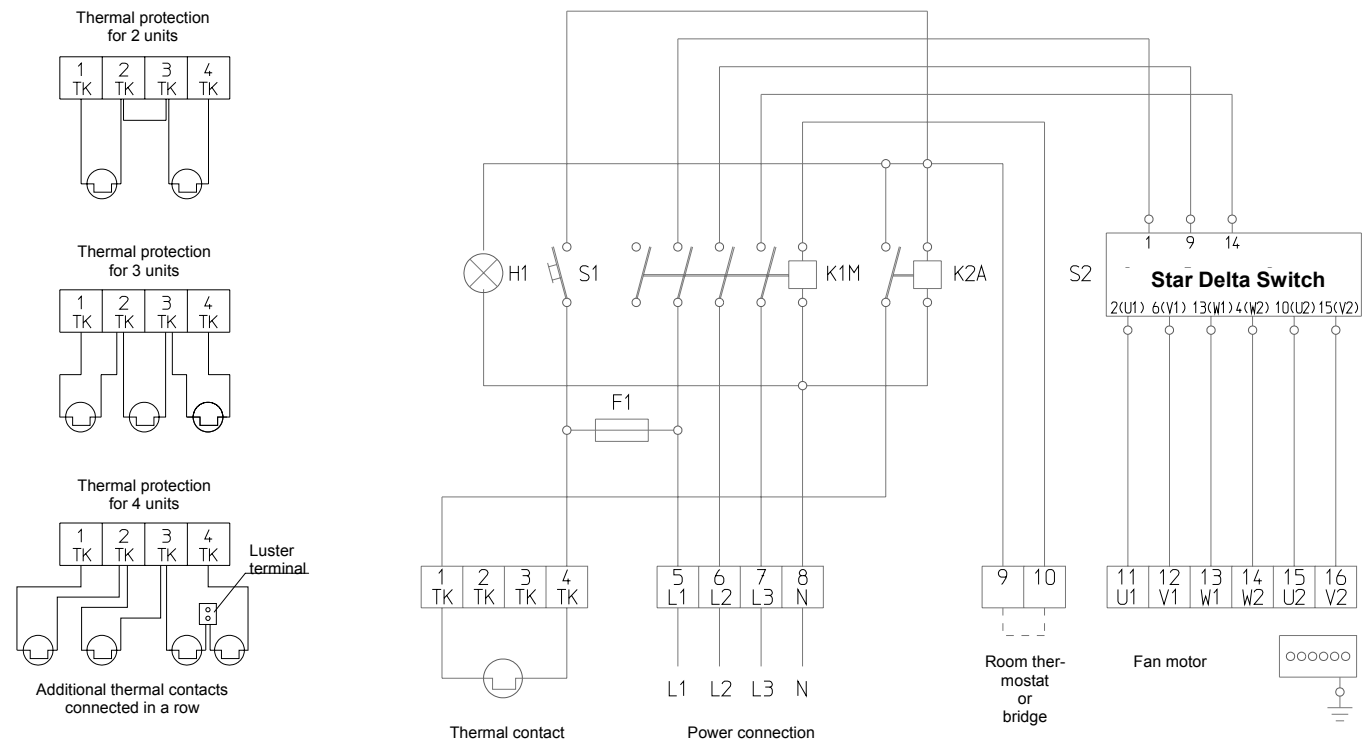

S1 Fan reset button
S2 Control switch

K2A Auxiliary relay
K1M Contactor to fan motor

F1 Control fuse
H1 Operating light

SW 1.1 W switching unit

**Rotary current 230 volt, fan 2-speed
maximum electrical capacity 4 kW**

Wall-mounted, full motor protection through integrated thermal contacts, room thermostats and frost protection thermostat.

Design

Plastic housing, protection type IP 65.

Protective insulation in accordance with VDE, front plate with symbols for switching positions and operating modes, power input and protective conductor terminals, main contactor, speed selector with the functions "0 / 1", control fuse, operating and malfunction lights, operating mode switch with the functions "Off / Release / Thermostat / Continuous Operation", control relay, terminals for the motor output, connection terminals for thermal contacts, room thermostats and frost protection thermostat.

Functionality

The frost protection thermostat switches the fan off.

Switching on again after a problem

Each time the power supply is interrupted or the fan malfunctions, the operating mode switch has to be reset to "0/Release"!

Group switching

The switching unit is suitable for group switching. Several motors wired the same way can be connected to one switching unit.

The total capacity of the connected motors may not exceed the permissible switch capacity of the switching unit. The thermal contacts of all motors are to be connected in a row.

Important information about safe operation

Grounding and earthing or protective wiring and fuse protection must be done by the customer in accordance with the requirements of the VDE as well as the responsible EVU.

The electrical unit connections must be performed by authorised personnel in the line with the valid requirements in compliance with local laws and in accordance with the wiring diagrams.

Wiring diagram

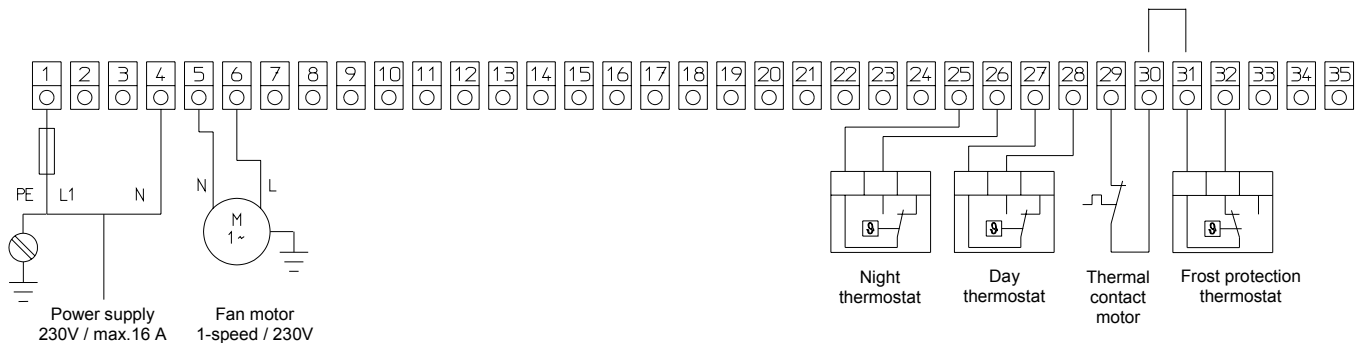

If several fans are operated simultaneously up to a total capacity of max. 4 kW, the connection is made via an external terminal distributor!

If several fans are operated simultaneously, connect all thermal contacts in a row!

Wiring diagrams of the thermal contacts

Thermal protection for 2 units

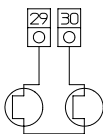

Thermal protection for 3 units

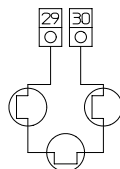

Thermal protection for 4 units

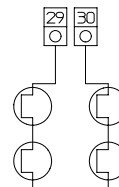

SW 2.1 D switching unit

Rotary current 400 volt, fan 2-speed maximum electrical capacity 4 kW

Wall-mounted, full motor protection through integrated connections for thermal contact, connection terminals for thermal contacts, room thermostats and frost protection thermostat.

Design

Plastic housing, protection type IP 65.

Protective insulation in accordance with VDE, front plate with symbols for switching positions and operating modes, power input and protective conductor terminals, main contactor, speed selector with the functions "Speed 1 / Speed 2", control fuse, operating and malfunction lights, operating mode switch with the functions "Off / Release / Thermostat / Continuous Operation", control relay, terminals for the motor output, connection terminals for thermal contacts, room thermostats and frost protection thermostats.

Functionality

The frost protection thermostat switches the fan off.

Switching on again after a problem

Each time the power supply is interrupted or the fan malfunctions, the operating mode switch has to be reset to "0/Release"!

Group switching

The switching unit is suitable for group switching. Several motors wired the same way can be connected to one switching unit.

The total capacity of the connected motors may not exceed the permissible switch capacity of the switching unit. The thermal contacts of all motors are to be connected in a row.

Important information about safe operation

Grounding and earthing or protective wiring and fuse protection must be done by the customer in accordance with the requirements of the VDE as well as the responsible EVU.

The electrical unit connections must be performed by authorised personnel in the line with the valid requirements in compliance with local laws and in accordance with the wiring diagrams.

Wiring diagram

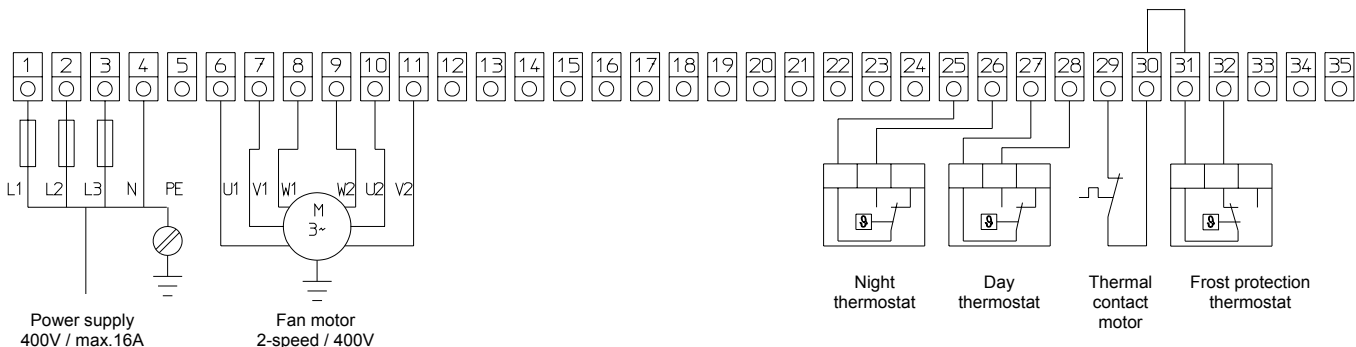

If several fans are operated simultaneously up to a total capacity of max. 4 kW, the connection is made via an external terminal distributor!

If several fans are operated simultaneously, connect all thermal contacts in a row!

Wiring diagrams of the thermal contacts

Thermal protection for 2 units

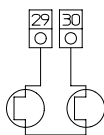

Thermal protection for 3 units

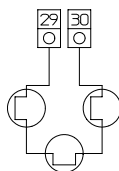

Thermal protection for 4 units

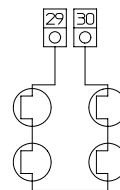

SW 2.2 DSK switching unit

Rotary current 400 volt, fan 2-speed maximum electrical capacity 4 kW

Wall-mounted, full motor protection through integrated connections for thermal contacts, connection terminals for thermal contacts, room thermostats, frost protection thermostat and mixed-air box adjustment motor.

Design

Plastic housing, protection type IP 65.

Protective insulation in accordance with VDE, front plate with symbols for switching positions and operating modes, power input and protective conductor terminals, main contactor, speed selector with the functions "Speed 1 / Speed 2", control fuse, operating and malfunction lights, operating mode switch with the functions "Off / Release / Thermostat / Continuous Operation", control relay, terminals for the motor output, connection terminals for thermal contacts, room thermostats, frost protection thermostats, mixed-air adjustment motor and flap positioning switch.

Functionality

The mixed-air box can be controlled by means of a flap positioning switch. If the ventilation is shut off, the flaps are automatically set to "Closed".

The frost protection thermostat closes the flaps switches the fan off.

Switching on again after a problem

Each time the power supply is interrupted or the fan malfunctions, the operating mode switch has to be reset to "0/Release"!

Group switching

The switching unit is suitable for group switching. Several motors wired the same way can be connected to one switching unit.

The total capacity of the connected motors may not exceed the permissible switch capacity of the switching unit. The thermal contacts of all motors are to be connected in a row.

Important information about safe operation

Grounding and earthing or protective wiring and fuse protection must be done by the customer in accordance with the requirements of the VDE as well as the responsible EVU.

The electrical unit connections must be performed by authorised personnel in the line with the valid requirements in compliance with local laws and in accordance with the wiring diagrams.

Wiring diagram

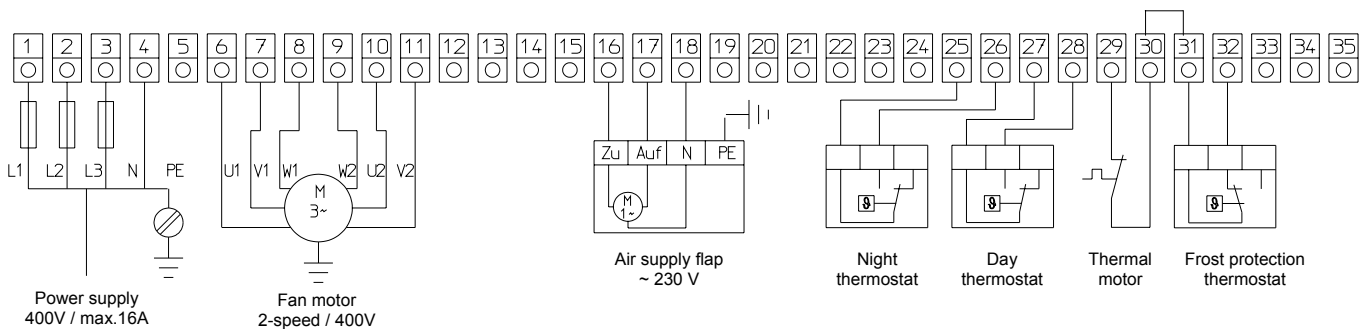

If several fans are operated simultaneously up to a total capacity of max. 4 kW, the connection is made via an external terminal distributor!

If several fans are operated simultaneously, connect all thermal contacts in a row!

Wiring diagrams of the thermal contacts

Thermal protection for 2 units

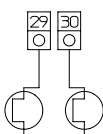

Thermal protection for 3 units

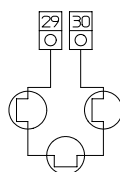

Thermal protection for 4 units

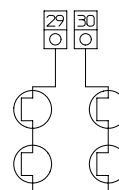

SW 2.2 DPP switching unit

**Rotary current 400 volt, fan 2-speed
maximum electrical capacity 4 kW**

Wall-mounted, full motor protection through integrated connections for thermal contacts, connection terminals for thermo contacts, frost protection thermostat and mixed-air box adjustment motor.

Design

Plastic housing, protection type IP 65.

Protective insulation in accordance with VDE, front plate with symbols for switching positions and operating modes, power input and protective conductor terminals, main contactor, speed selector with the functions "Speed 1 / Speed 2", control fuse, operating and malfunction lights, operating mode switch with the functions "Off / Release / Thermostat / Continuous Operation", control relay, terminals for the motor output, connection terminals for thermal contacts, room thermostats, frost protection thermostats and mixed-air adjustment motor as well as gradual control of the mixed-air box motor via remote potentiometer.

Functionality

The reverse flaps in the mixed-air box can be controlled gradually by means of a remote potentiometer. If the ventilation is shut off, the flaps are automatically set to "Closed".

The frost protection thermostat closes the flaps and switches the fan off.

Switching on again after a problem

Each time the power supply is interrupted or the fan malfunctions, the operating mode switch has to be reset to "0/Release"!

Group switching

The switching unit is suitable for group switching. Several motors wired the same way can be connected to one switching unit.

The total capacity of the connected motors may not exceed the permissible switch capacity of the switching unit. The thermal contacts of all motors are to be connected in a row.

Important information about safe operation

Grounding and earthing or protective wiring and fuse protection must be done by the customer in accordance with the requirements of the VDE as well as the responsible EVU.

The electrical unit connections must be performed by authorised personnel in the line with the valid requirements in compliance with local laws and in accordance with the wiring diagrams.

Wiring diagram

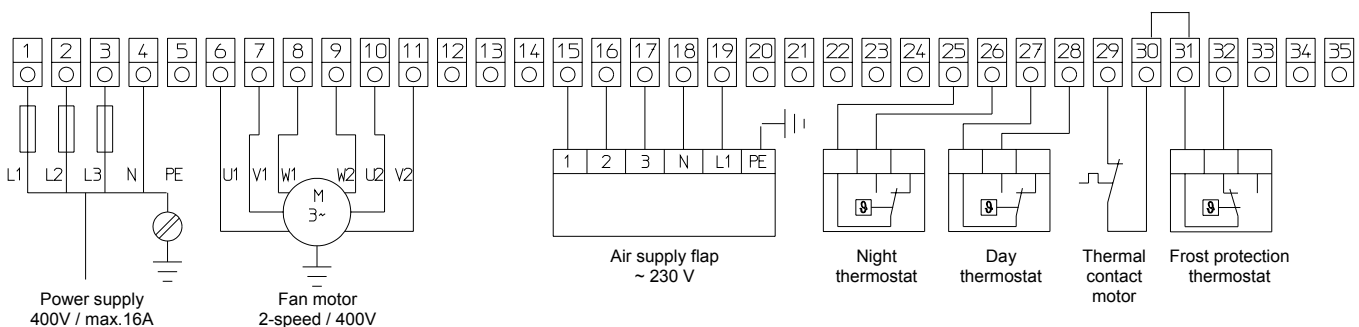

If several fans are operated simultaneously up to a total capacity of max. 4 kW, the connection is made via an external terminal distributor!

If several fans are operated simultaneously, connect all thermal contacts in a row!

Wiring diagrams of the thermal contacts

Thermal protection for 2 units

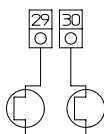

Thermal protection for 3 units

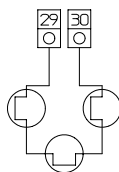

Thermal protection for 4 units

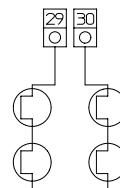

Motor control units, 5-speed

5-speed control unit for alternating and rotary current with operating light. The motor is protected by connecting thermal contacts.

Should a problem occur (when the thermal contacts are activated), the internal main contactor lapses and interrupts the power supply to the motor. After the cause of the problem has been removed, the speed selector can be reset.

It is possible to connect the control units to a room thermostat that switches the unit on and off.

Switching unit	Voltage V	Power A	Protection type IP	Weight kg
RTRE 3.5	230	3.2	54	3.5
RTRE 7	230	7.5	54	7.5
RTRD 2.5	400	2.5	54	10.5
RTRD 4.5	400	4.5	54	15.1

Terminal panel wiring diagram 5-speed switching unit RTRE

Input current : 230V/1~ /50 Hz

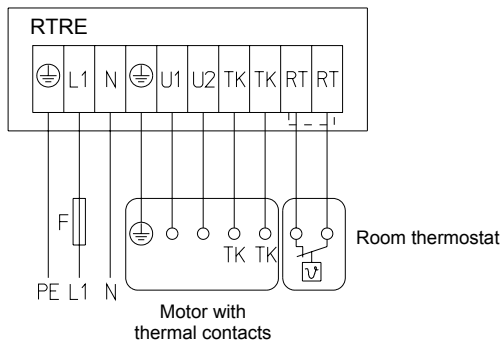

Terminal panel wiring diagram 5-speed switching unit RTRD

Input current : 400V/3N~ /50 Hz

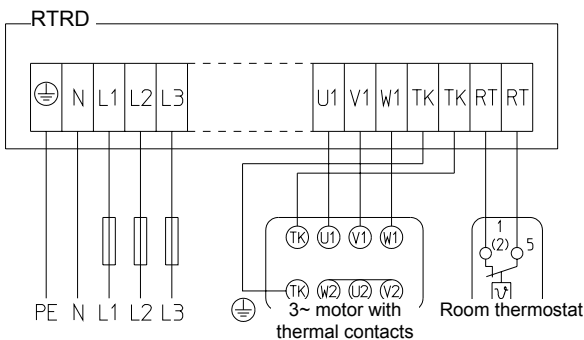

Fan motor wiring diagrams

Motor with 2 speeds, Δ / Y switch and thermal contacts

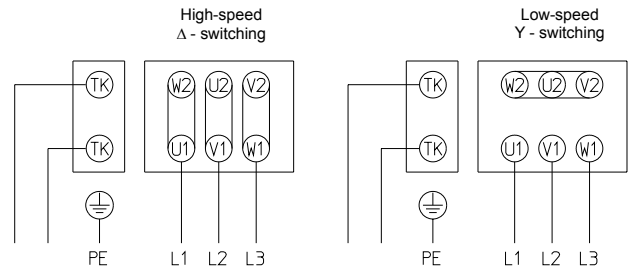

Motor with one speed and thermal contacts

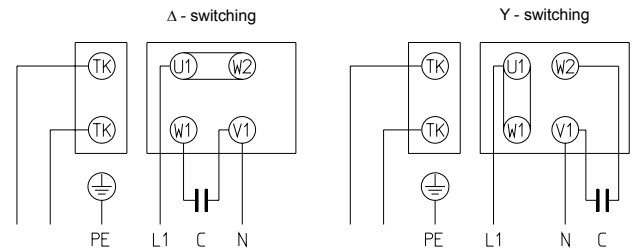

Single phase alternating current motor with operating condenser and thermal contacts

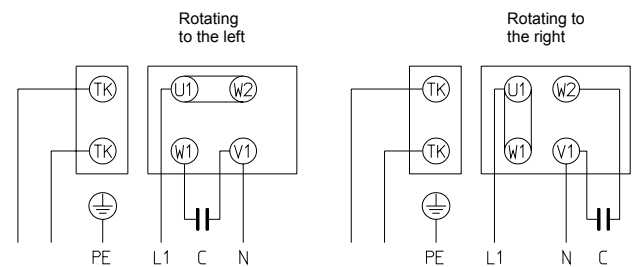

REMKO GmbH & Co. KG

Klima- und Wärmetechnik

32791 Lage, Im Seelenkamp 12

32777 Lage, PO Box 1827

Phone +49 5232 606-0

Fax +49 5232 606-260

E-mail info@remko.de

Internet www.remko.de