

# **REMKO WKL INOX**

## **Wall-mounted oil-fired heaters**

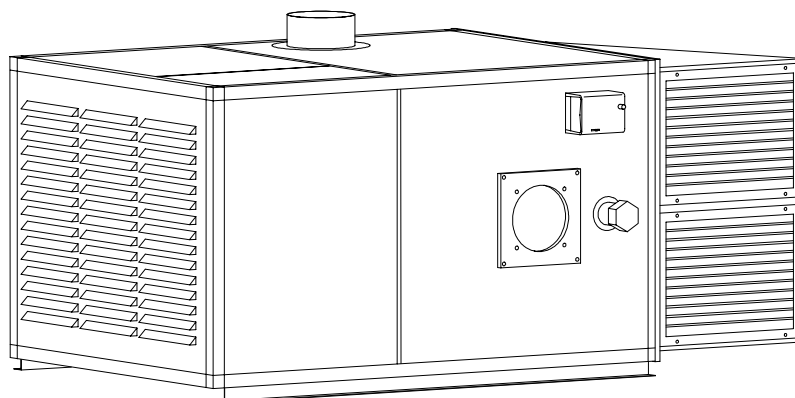

**Operation**  
**Technology**  
**Spare Parts**



# Operating Instructions

Read these instructions carefully before setting up/operating the unit!

Our guarantee becomes null and void if the unit is used, set up or maintained improperly, or if modifications are made to the supplied unit without our prior consent.

Subject to alterations!

## Stationary Warm Air Heating Systems REMKO WKL INOX

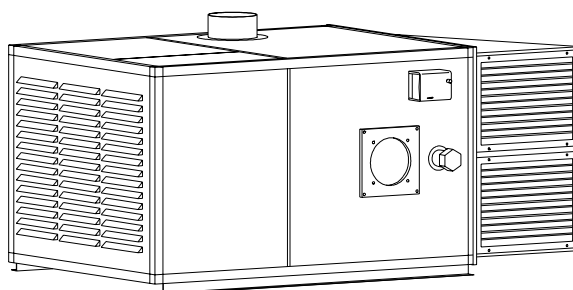

<b>Contents</b>	<b>Page</b>	<b>Contents</b>	<b>Page</b>
Safety Instructions	4	Troubleshooting	13
Description of the Unit	4	Maintenance and Service	14
Safety Device	5	Exploded View	15
Prior to Setup	6	Spare Part List	15
Exhaust Connection	9	Wiring Diagram 230 V	16
Service and Guarantee	9	Wiring Diagram 400V Direct Start	17
Setup and Assembly	10	Technical Data	18
Starting	11	Maintenance Log	19
Unit Shut Down	12		



Always keep these operating instructions near or on the unit!



## Safety Instructions

Make sure to observe relevant local building and fire protection codes and abide by professional association regulations when the units are in operation!

- ◇ Before performing any maintenance or repair work, make sure to unplug the units from the power supply! *Remove fuses or switch off the customer-supplied main switch.*

 **It is not sufficient to switch off the units with the operating switch!**

- ◇ The units may only be operated by persons who have received proper training in their operation.
- ◇ The units must be installed and operated in such a way that people are not exposed to radiant heat and fires cannot occur.
- ◇ The units may only be installed and operated in closed rooms where the units have adequate air supply for combustion. *If this cannot be guaranteed, a separate burner-driven device that sucks in fresh air from the outside must be installed.*
- ◇ The units may only be set up on a non-flammable surface.
- ◇ The units may only be attached to non-flammable, sturdy structures or ceilings made from the materials with sufficient load-bearing capacity.
- ◇ The units are to be attached with sturdy mounts which are fixed on the unit.
- ◇ The units may not be set up or operated in surroundings susceptible to fire or explosions.
- ◇ The units must be set up outside of traffic zones, e.g. away from cranes.
- ◇ A safety zone of 1 m is to be maintained around the units.
- ◇ The protective air suction grille must always be kept free of dirt and loose objects.
- ◇ Never insert foreign objects into the units.
- ◇ Do not expose the units to a direct stream of water.
- ◇ Never let water get inside the units.
- ◇ All of the units' electrical cords are to be protected from damage (e.g. caused by animals, etc.).

 **Do not bypass or block safety mechanisms while the unit is in operation.**

 **These units have not been designed for heating private residences or similar spaces.**

## Description of the Unit

The units (automatic heaters) have been designed for universal, fully-automatic and smooth operation. They are fired directly with heating oil or diesel.

### Function and Design

The units have been designed for operation with a separate forced-air burner in single-stage operation. 2-stage burners may only be operated to prevent condensation from accumulating during startup in partial load range.

It is essential to connect the units to an exhaust system approved by the state building authorities.

The units are equipped with single setting, quiet radial ventilators with drive motors requiring little maintenance and with integrated switches and control devices depending on the type of unit.

The units meet the basic safety and health requirements found in the relevant EU regulations. They are safe and easy to operate.

The robust design and clean processing of these high-quality units ensure a long service life and smooth operation. They can also be assembled quickly, easily and affordably and are easy to service.

### Operating Locations of the Units

The units are direct-fired devices that supply instantaneous heat. They are only used for industrial and commercial purposes. There are generally no restrictions as to where they can be used.

REMKO automatic heaters supply heat or regulate the temperature of:

- ◇ Workshops
- ◇ Warehouses
- ◇ Exhibition spaces
- ◇ Trade show spaces
- ◇ Temporary structures for warehousing
- ◇ Showrooms
- ◇ Greenhouses etc.

### Proper Use

The units have been designed and equipped exclusively for industrial and commercial heating and ventilation purposes.

The manufacturer assumes no liability for damage resulting from non-compliance with manufacturer specifications and legal requirements, or if modifications are made to the units.

## Operation

After switching on the unit by setting the operating switch to „I“ or “Heizen” (heating), the forced-air burner turns on automatically.

For the 400 V model, the “burner“ operating light is illuminated on the control box for monitoring purposes. The combustion chamber with heat-exchanger now heats up until the target temperature is reached.

After the set target temperature is reached, the air supply fan switches on automatically. The “Fan” operating light on the control box also lights up on the 400 V model for monitoring purposes. Warm air is blown out.

Depending on how much heat is required, the process described is repeated.

If heating mode is controlled via a room thermostat or other temperature regulating device (operating switch set to „I“ or “Heizen” (heating), the units function fully-automatically based on amount of heat required.

All of the unit functions are performed automatically and monitored by the triple combination control and the automatic burner relay (part of the forced-air burner).

After the device is switched off with the operating switch or the room thermostat, the air supply fan runs for a certain amount of time to cool the combustion chamber with heat-exchanger and then switches off. This process can be repeated several times.

**Never interrupt (except in emergency situations) the power supply until the cool-down phase is completely finished.**  
**Our guarantee does not cover damages caused to the unit by overheating.**

If the flame burns irregularly or goes out, the unit is switched off by the automatic burner relay.

The automatic burner relay’s malfunction light as well as the “Burner” malfunction light (the 400 V mode only) on the control box light up. The unit may only be restarted after the automatic burner relay has been manually released.

The safety temperature limiter (STB) interrupts operation of the unit or burner when extreme overheating occurs or if the TW ceases functioning. The STB can only be manually released after the unit has cooled.

For units in the 400 V series, the fan motor is also monitored by a thermal overcurrent relay.

If the motor becomes overloaded, operation is interrupted by the relay and the red malfunction lamp “Ventilator” (fan) on the control box lights up. Release is only possible after the control box has been opened.

**Before releasing the overcurrent relay, the possible causes of the malfunction must be investigated.**

# Safety Device

## Triple combination control

The device has 3 safety functions:

- ◇ Fan control thermostat (TR)
- ◇ Temperature monitor (TW)
- ◇ Safety temperature limiter (STB)

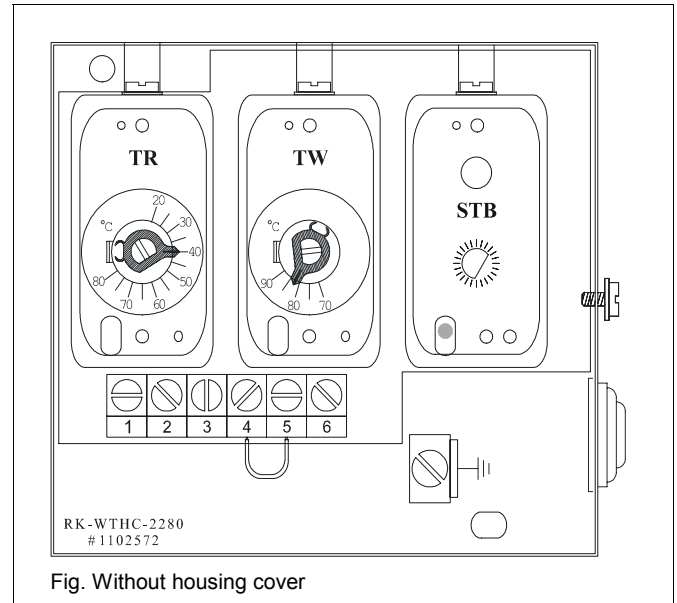

## The 3 functions of the triple combination control

### 1. Fan control thermostat (TR)

The fan control thermostat switches the circulating air fan off and on. The switching point is set via the temperature control thermostat “TR”.  
*Rated value approx. 40°C.*

### 2. Temperature monitor (TW)

When the unit is in heating mode, the temperature monitor limits both the temperature of the unit and the air being blown out. The switching point is set via the temperature control thermostat “TW”.  
*Rated value approx. 80 to 85°C.*

### 3. Safety temperature limiter (STB)

The STB controls the temperature monitor.  
*The switching point is fixed.*

The burner is prevented from being restarted if the STB is activated. The reset button is operated from outside.

**Before the STB is released (to restart operation), the reason the STB was activated must be determined.**

### Important information about the triple combination control

The device is equipped with a sensor monitoring feature and is cold-resistant down to  $-20^{\circ}\text{C}$ ; below  $-20^{\circ}\text{C}$  the device switches off; when the temperature rises above this temperature, it switches on again.

When the sensor or the capillary tube is damaged, or when an overtemperature of approximately  $220^{\circ}\text{C}$  is reached, the filling medium is emptied and the device performs a safety switch-off operation.

The device is no longer operable and must be replaced.

 **The triple combination control may only be replaced with an original REMKO spare part!**

 **Installation and assembly must be performed safely and properly.**

Make sure to observe the following general instructions as well.

- ◇ When the safety facility has to be replaced, take care not to damage or excessively bend the capillary tubes.
- ◇ Bends may only occur on the capillary tubes and not on the sensor.
- ◇ To ensure that the unit functions properly, the sensors must always rest loosely in the warm air current.
- ◇ The sensors must always be free from dust and dirt.
- ◇ When mounting, the sensor and the capillary tubes may not be damaged or bended sharply edged.
- ◇ The sensors may not come into contact with the combustion chamber or other metal parts.
- ◇ The sensors must be fixed in the mounting brackets provided by the factory.

 **Do not bypass or block safety mechanisms while the unit is in operation.**

## Prior to Setup

When setting up the units, the relevant regional building and fire protection codes of the respective region must be observed.

### Selecting the Setup Location

When selecting a location to set up the units, the requirements must be adjusted with respect to:

1. Fire protection and operating hazards.
2. Function.  
*When the units are used to heat rooms, when it is necessary to adjust to the amount of pressure in the room, etc.*
3. Operating needs.  
*Heating requirements, rated air output, need for circulation or outside air, humidity, room temperature, air distribution, space needs, etc.*
4. How the unit is connected to the exhaust system.

Oil fired warm air generators (including those with a rated heat capacity of more than 50 kW) may generally be set up outside of heating rooms in compliance with the German fire ordinance.

For rooms where slightly flammable materials or mixtures are processed, stored or produced that could be dangerous if ignited, exceptions may be made if appropriate measures are taken to ensure that the materials or mixtures cannot catch fire.

 **The unit must be set up and assembled in such a way that it is easily accessible for monitoring, repair and maintenance work.**

### Air Supply for Combustion

An adequate supply of air for combustion must be ensured by meeting the relevant building requirements.

Excerpts from the German fire ordinance:

- (1) For furnaces with a total rated heat output of up to 35 kW that are dependent on the air in the room, evidence of an adequate air supply for combustion has been provided if the furnaces are set up in a room that has:
  1. A minimum of one door to the outside or a window that can be opened (rooms with a connection to the outside) and a room capacity of at least  $4\text{ m}^3$  per kW of total rated heat output or
  2. An opening leading to the outside with a cross-section of at least  $150\text{ cm}^2$  or two openings which are each  $75\text{ cm}^2$  or lines to the outside with equivalent cross-sections for air flow.
- (2) For furnaces with a total rated heat output of more than 35 kW and less than 50 kW that are dependent on the air in the room, evidence of an adequate air supply for combustion has been provided if the furnaces are set up in rooms that meet the requirements of Para. 1, No. 2.

- (3) For furnaces with a total rated heat output of more than 50 kW that are dependent on the air in the room, evidence of an adequate air supply for combustion has been provided if the furnaces are set up in rooms that have an opening or a line leading to the outside.

The cross-section of the opening must be at least 150 cm<sup>2</sup> plus an additional 2 cm<sup>2</sup> for each kW of rated heat output which is above 50 kW.

The lines' cross-sections must have equivalent measurements for air flow. The required cross-section may not be divided among any more than 2 openings or lines.

- (4) Combustion air openings and lines may not be closed or blocked unless the safety mechanisms can ensure that the furnace can only be operated when the flap is closed. The required cross-section may not be constricted by the flap or the grille.
- (5) As an exception to Paras. 1 to 3, for furnaces dependent on air in the room, evidence of an adequate air supply for combustion can be provided other ways.

For example by:

A continuous line to the outside with a sufficient cross-section that is attached to the burner or its lining. This must be adjusted to the suction capacity of the burner and the line resistances (including the protective air suction grille) so that combustion is assured.

### Important Information about Safe Setup

- ◇ The units may only be set up and operated in rooms where there is enough air for combustion and the expelled air is guided to the outside via an exhaust system.
- ◇ Units dependent on air in the room may only be set up in rooms or buildings from which air is suctioned out by means of fans (such as ventilation or exhaust systems) if:
  1. Safety mechanisms prevent the units and the air suctioning system(s) from operating simultaneously.
  2. The expulsion of exhaust is monitored by special safety devices.
  3. The exhaust produced by the units is expelled by means of the air suctioning system(s).
  4. The design or dimensions of the system ensure that no dangerous negative pressure can be produced.
- ◇ The units must be placed firmly on a suitable, non-flammable surface outside of traffic zones, for example, away from cranes.

- ◇ The units must be set up and operated in such a way that people are not exposed to exhaust or radiant heat and fires cannot occur.
- ◇ The units must be set up in such a way that they do not cause any hazards or unreasonable annoyances, e.g. tremors, vibrations or noise.
- ◇ The units must be set up and installed in such a way that they are easily accessible for monitoring, repair and maintenance work.
- ◇ Operating elements which can result in dangerous operating conditions when used improperly must be protected from unauthorised operation if they are generally accessible.
- ◇ We do not recommend suctioning in outside air directly with the standard combustion chamber. When mounting the mixed air flaps (accessories), they must be attached in the opposite direction. The percentage of fresh air supplied may not exceed 30%.
- ◇ The units may not be set up or operated in rooms or areas susceptible to fire or explosions.

 **The units are suitable for operation when accessories are attached to the air intake or outlet sides.**

 **The units are not suitable exclusively for use as air supply units.**

### Heating Rooms

The units only may be operated in closed rooms or warehouses if they have been equipped with a suitable room temperature control thermostat (room thermostat).

### Setup on the Ground

The units must be placed firmly on non-flammable surface outside of traffic zones, e.g. away from cranes.

A safety zone of 1 m must be maintained around the units to protect them from damage in commercial rooms, to ensure unhindered access for maintenance and repair work on the unit and burner and, if necessary, to prevent air intakes and outlets from blockage.

This safety zone is to be identified with a warning sign that says:

**Maintain a Safety Zone of 1 m**

We recommend clearly marking heavily trafficked areas.

## Wall Assembly

The wall where the unit is to be assembled may not be made of flammable materials. Its load-bearing capacity must be tested and, if necessary, reinforced.

Consoles must be anchored firmly to the wall and the units attached here. There must be adequate room to perform maintenance work on the heat-exchanger, burner, fan and exhaust system.

You must observe the following.

- ◇ Operating mechanisms for the unit and the combustion air supply must be able to be operated from the ground.
- ◇ Tools needed for monitoring, service and repair work must be supplied by the operator.

## Assembling Suspended Units

The units may only be attached to sturdy structures or ceilings that are made of non-flammable materials and have adequate load-bearing capacity.

Sturdy mounts fixed on the unit are used to attach it. In addition, the requirements listed in the section "Wall Assembly" must be observed.

## Outside Setup

Units that are set up outside must be adequately protected from weather conditions so that they do not have any harmful effects or cause any unreasonable annoyances during operation.

The units may only be equipped with armatures and control devices that are suitable for outside use. If not, the control devices and switches must be protected accordingly.

## Power Supply

Prior to performing the electrical installation in line with local requirements, check whether it is possible for even a temporary power overload to cause an impermissible undervoltage.

To connect the units, the line cross-sections are to be placed in such a way that they do not caused the burner voltage to lower to an impermissible level when the fan is started.

When connecting the units in the 400 V series, make sure that the phase sequence of the rotational field is correct. The fan could rotate in the wrong direction if this connection is not correct.

An easily accessible emergency switch must be attached in the setup room, but not close to hazardous areas.

 **All generally accessible switches must be protected against damage and unauthorised use!**

## Fuel Supply

Particularly for heating oil lines, make sure that the cross-section of the lines corresponds to the suction height, the total line resistance and increased viscosity at lower temperatures and, if necessary, it is possible to connect an oil transport device.

The lines must be placed in such a way that they are easily ventilated and are protected from corrosion and mechanical damage.

 **The measured pressure of the suction line should not exceed -0.3 bar. It may be a maximum of -0.4 bar.**

## Annual Inspection and Service

The operator must have the unit checked and serviced as necessary, at least once a year, by a representative of the manufacturing company or another authorised individual in accordance with the operating conditions.

The units must be checked for operational readiness, functional safety, efficiency and compliance with emission limits.

The operator must be informed if defects are found. He must then have the unit serviced immediately or its components replaced.

The following applies:

Maintenance work on limiting devices, self-adjusting devices and flame monitoring devices as well as on other safety mechanisms may only be performed by the respective manufacturer or his representatives.

On the other hand, the individual contracted to service the unit may only replace components or assemblies with those provided by the manufacturer or his representatives.

 **The units are intended to be used exclusively for industrial and commercial purposes. They are not intended to heat residences or similar rooms.**

# Exhaust Connection

The unit is to be connected to suitable exhaust systems whose design has been approved.

 **Installation of an exhaust system always requires a permit.**

Exhaust systems are structural systems located either in or on buildings whose sole purpose is to expel exhaust from heating appliances safely above the roof.

When planning for the exhaust system, please observe the following:

- ◇ The exhaust system must be installed and assembled properly and in accordance with the relevant regulations.
- ◇ The dimensions of the exhaust lines must be adjusted to the capacity of the unit and the construction height.
- ◇ The dimensions of the exhaust systems must ensure that the exhaust is expelled to the outside regardless of the operating conditions and guarantee that no positive pressure is produced in the rooms. These dimensions are based on the cross-section and height, and to the extent required, the heat penetrability resistance and internal surface.
- ◇ The exhaust system openings must stick out at least 40 cm beyond the top of the roof or be at least 1 m away from the surface of the roof.
- ◇ If impact pressures, e.g. from fall winds or neighbouring buildings, are anticipated, the top of the chimney should be shaped accordingly.
- ◇ The exhaust system must be attached securely and properly according to the manufacturer's specifications.
- ◇ In roof structures, the exhaust system must be led through a pipe casing or a chute to allow the exhaust line to expand when heated.
- ◇ The unit connection must be impermeable and secured with rivets or screws from becoming accidentally loose.
- ◇ It is preferable to have a horizontal exhaust line that is as short as possible.  
*Incline 2 % = 2 cm/m.*
- ◇ You should plan to have a closable opening for performing measurements at a distance of 2 x Ø exhaust pipe behind the unit connection.  
*Under certain circumstances, it is possible to measure the exhaust opening.*
- ◇ The double-walled, REMKO stainless steel exhaust systems have been approved by the *Institut für Bautechnik* (German Institute for Construction Engineering) in accordance with DIN 18160 Part 1.

 **Make sure to maintain a safe distance to flammable materials!**

## Examples of Use

Double-sided exhaust system / stainless-steel / outside assembly.

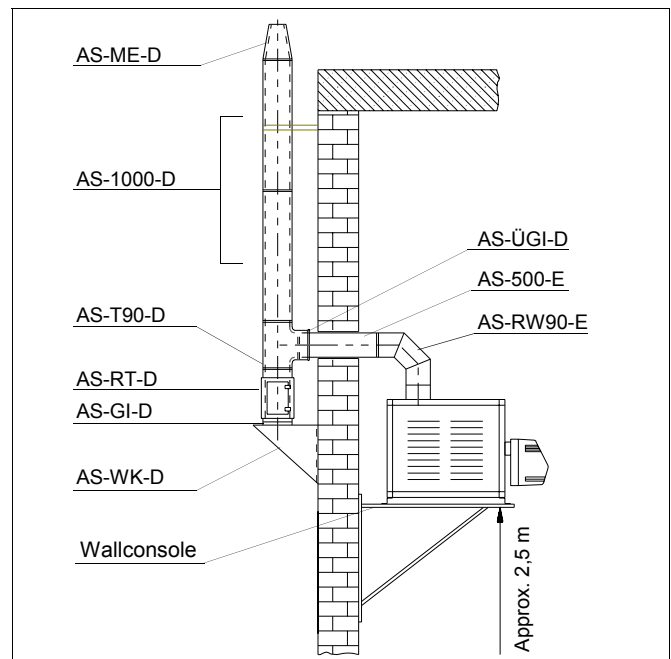

## Service and Guarantee

For the guarantee to be valid, the customer must completely fill out the "guarantee certificate" enclosed with all heating units and send it back to REMKO GmbH & Co. KG in a timely manner after purchasing of the unit and putting it into operation.

The units have undergone several tests to ensure proper functioning at the factory. If there are still malfunctions that cannot be fixed by the operator using the troubleshooting instructions, please contact your dealer or contract partner.

 **An operation/use other than indicated in these instructions is prohibited!**

**In the case of non-compliance, we assume no liability and our guarantee becomes null and void.**

### Proper Use

These units have been designed and equipped exclusively to be used for heating and ventilation for industrial and commercial purposes.

The manufacturer is not liable for any damage resulting from non-adherence to manufacturer specifications, legal requirements or any modifications to the units.

# Setup and Assembly

## Unit Setup

When setting up the units, the regional provisions and regulations must be observed.

The units may only be operated with accessories that have either been approved by the manufacturer or supplied with the units.

Proceed as follows to set up the units:

1. Remove the transport pallets or crates or other packaging material before set up/assembly.
- ◇ Check the units for any damage.
  - ◇ When assembling, place the units securely on the ground, preferably on a separate platform and ensure that they are current-free.
  - ◇ Make sure that the fan capacity (rated pressure) has been adjusted to the corresponding resistance on the air side.  
*Measure rated current.*
  - ◇ Make sure that air can flow freely into and out of the units.
  - ◇ Make sure that there is a sufficient supply of air for combustion.
  - ◇ If there are unfavourable pressure conditions in the setup room or strong air impurities, install a burner-driven device that sucks in fresh air from the outside.
  - ◇ Guide the suctioned air via appropriate filters (accessories) if the air in the setup room is expected to be quite dirty.  
*Pay attention to the resistance on the air intake side and adjust the fan capacity accordingly.*

 **Air may only be suctioned in via the air intake openings for this purpose. If the bottom of the unit has not been equipped for air intake, it must be closed to prevent the incorrect intake of air.**

## Exhaust Connection

The exhaust connection must be made properly in accordance with the relevant regulations.

- ◇ Proper exhaust expulsion must be ensured.
- ◇ The exhaust connection may only be made to a previously approved exhaust system.

## Electrical Installation

The electrical connection of the units may only be performed by authorised personnel in accordance with the relevant regulations (including any local ones).

- ◇ An easily accessible emergency switch must be attached in the setup room.

## Thermostat Connection

The room thermostat (accessory) or day/night regulator (accessory) is connected via special connections. You must observe the following.

- ◇ The room thermostat (accessory) must be placed in the most ideal location in the room for regulating temperature.
- ◇ The thermostat sensor may not be exposed directly to a particularly cold or warm air current.
- ◇ The process is the same for installation of an automatic day/night temperature regulator (accessory).

### 230 V/1~ model

For the control boxes of the 230 V / 1~ model, a room thermostat or a day/night temperature control mechanism is connected to the thermostat sockets standard for this series .

The connection is made as follows.

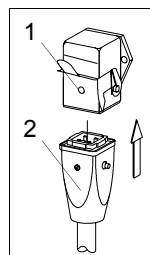

Unplug the existing bridge plug and connect the Thermostat plug 2 to the Thermostat socket 1 on the control box.

When using control units without a standard series thermostat plug, it can be purchased as an accessory.  
*Ref. no. 1101020.*

### 400 V / 3~ models

The connection of a room thermostat or a day/night temperature control mechanism is made to the corresponding terminal strips.

The connection is made as follows:

Remove the bridge and assign the terminal strips with the corresponding wires of the control mechanism.

### 400 V / 3~, Direkt Start

Terminal strip **X2**

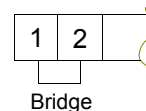

## Fan Motor Connection

The units are completely wired at the factory.

If modifications are made or the fan motors are replaced, make sure that the motor is properly connected.

### Burner Installation

The forced-air burner supplied by the manufacturer is attached to the front of the unit with a clamp flange.

You must observe the following:

- ◇ Only forced-air burners with automatic burners that have a 5 sec. safety period may be used.
- ◇ It is not necessary to limit the capacity in single-stage burner operation for the warm air generator.
- ◇ The burner must be adjusted to the full heat load of the unit.
- ◇ The combustion chamber may not be operated below capacity.
- ◇ The exhaust temperature may not fall below 160 degrees Kelvin above the room temperature.  
*Condensation accumulation.*
- ◇ Follow the operating instructions of the burner supplied by the manufacturer.
- ◇ If burners from other manufacturers are used, they must be checked for compatibility with the unit.

### Heating Oil Connection

Make sure that there is an adequate supply of fuel.

- ◇ The suction line must be equipped with a valve at the end of the hose in the tank.
- ◇ Even when outside temperatures are low, a sufficient amount of heating oil must be able to flow freely. Paraffin can accumulate at temperatures starting at approximately 5 °C depending on the quality of the heating oil.  
*Appropriate measures must be taken to prevent this from happening.*

## Starting

### Fan Motor Operation

Check the drive.

1. Check that the tightening screws of the complete drive are secure.
2. Check the initial tension of the drive belt.
3. Check the rotational direction of the fan.

### Measuring the rated current and current consumption

1. To prevent inaccurate measurements, open the grille in the air duct or the blow-out cover and attach all air suction grilles to the unit.
2. Check the available power supply.
3. Measure the current.
  - Rated current for direct start  
The measured rated current may not exceed the value on the type plate of the motor.  
*The thermal overcurrent relay must be adjusted to the rated current of the drive motor.*
  - Rated current for Y /  $\Delta$  start.  
The measured rated current may not exceed the value on the type plate of the motor.  
*Multiply the rated current of the drive motor by a factor of 0.58 and adjust the thermal overcurrent relay to the calculated value.*



**Each phase should be measured separately to prevent inaccurate measurements.**

### Thermal Overcurrent Relay

To check the function of the overcurrent relay or its set value, remove a fuse. If the unit is functioning and set properly, the relay should activate after approximately 30 seconds.

### Important Hints about the Thermal Overcurrent Relay

The thermal overcurrent relay may only be operated when the relay is set to manual (H). The relay may not automatically switch on again after it has cooled.

When the relay is set to automatic (A), the possibility that damage will occur cannot be ruled out.

***There is no guarantee claim!***

### Current Consumption too High

If the motor is consuming too much current despite a proper electrical connection and adequate power supply, the thermal overcurrent relay may not be set higher or bypassed under any circumstances.

To correct the problem, the air intakes and outlets (possible air compression) must be checked and appropriate action taken.

## Initial operation

Initial operation of the unit and its forced-air burner must be performed by the manufacturer or one of its authorised service representatives. During this process, all regulating, control and safety mechanisms must be checked to ensure that they are functioning properly and set correctly.

- ◇ Oil and gas-fired units may only be put into initial operation by authorised personnel.
- ◇ Make sure that the fan's screws and bolts and burner attachments are secure.
- ◇ Open the blow-out grille if necessary and adjust it as required.
- ◇ Check the settings of the triple combination control.
- ◇ Switch the customer-supplied main switch or fuse on.
- ◇ Set the room thermostat to a higher value than the current room temperature.
- ◇ Open the fuel supply and set the operating switch to "Heizen" (heating).
- If the oil burner was supplied by the manufacturer, (up to WKL 60) the burner start is delayed as a result of the standard oil preheating process.*
- ◇ Adjust the throughput for the heating oil or gas to meet the heating capacity of the unit.  
*See the unit's type plate.*
- ◇ Set the burner to the optimum values in accordance with the manufacturer's specifications.
- ◇ Measure the chimney draught when cold and hot.
- ◇ Keep a protocol of measurements and submit it to the operator for safekeeping. Familiarise the operator with the system.
- ◇ Give the statement confirming the authorised company status and the company certificate of the respective installation company to the relevant authorities.

## Important information about corrosion in the heat-exchanger.

- ◇ **The exhaust gas temperature difference may not fall below 160 Kelvin.**  
*This keeps the temperature from falling below the dew point and prevents the resulting corrosion in the heat-exchanger.*
- ◇ If the unit is not set to its rated heat load or it is too large for the necessary heat requirements, the burner only runs in cyclical operation. Because the required operating temperature is not reached in cyclical operation, more condensation accumulates and there is more corrosion in the heat-exchanger.

## Heating Mode

The unit runs fully automatically with the temperature which has been pre-selected on the room thermostat.

Proceed as follows to put the unit into heating mode.

1. Turn the customer-supplied main switch or the fuse on.

2. Open the fuel supply.

3. Set the operating switch to "Heizen" (heating) or "I".

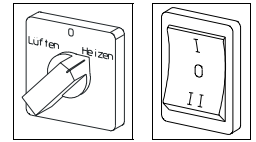

4. Adjust the room thermostat to the room temperature you want.

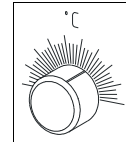

When heat is necessary, the forced-air burner switches on automatically. The air supply fan only switches on once the target temperature has been reached. This prevents cold air from being blown out.

## Ventilation

In this position only the supply air fan runs and the unit can be used for air circulation.

1. Set the operating switch to "Lüften" (fan) or "II".
2. Keep in mind that the unit's fan runs continuously.  
*It is not possible to control it with a thermostat*

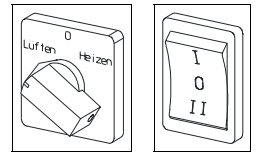

## Unit Shut Down

Set the operating switch to "0".

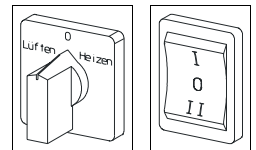

Keep in mind that the air supply fan continues running to cool down the heat-exchanger and can run several times before the unit is finally switched off.

**Never interrupt (except in emergency situations) the power supply until the cool-down phase is completely finished.**  
***Our guarantee does not cover damages caused to the unit by overheating.***

If the unit is taken out of operation for a longer period of time, the customer-supplied main switch or the fuse should be switched off and the fuel supply closed off.

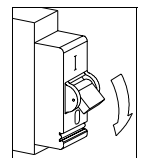

# Troubleshooting

 **For safety purposes, repair work on the electrical components and the burner may only be performed by authorised personnel.**

## The unit does not start

- ◇ Check the power supply.
- ◇ Check the fuses in the control box.  
*Only for units in the 400 V, 3 phase current series.*
- ◇ Check the temperature monitor.
- ◇ Check the safety temperature limiter.
- ◇ Keep in mind: before resetting the STB, it is absolutely necessary to determine the reason it was activated and take appropriate measures.

The following are possible causes:

- The unit could not cool down because the power supply was interrupted. Even short interruptions can activate the STB.
- The temperature of the air being blown out is too high because the grilles have not been properly adjusted.
- The fan was overloaded and the thermal overcurrent relay of the 400 V series was activated or the thermal contacts in the fan motor of the 230 V series were activated.
- The V-belt of the fan drive is loose or defective
- Air intakes and outlets are blocked.
- ◇ Check the operating and/or main switch.
- ◇ Check the room thermostat setting.  
*The room thermostat must be set higher than the room temperature..*
- ◇ Set the operating switch to “Lüften” (fan) or “II”.  
*If the air supply fan starts now, look for the problem in the burner.*

## The burner does not start

- ◇ Check whether the fuel filter is dirty.
- ◇ Check that all shut-off valves in the fuel supply are open.
- ◇ Check that there is enough fuel in the fuel container.
- ◇ Check whether paraffin has accumulated in the heating oil or in the fuel filter.  
*This can occur at temperatures below 5 °C.*
- ◇ Check oil lines for damage.  
*Leaks can cause air intake.*
- ◇ Use suitable means to ensure that the safety temperature limiter (STB) and the temperature monitor (TW) are functioning properly.
- ◇ Check the sensors and capillary pipes of the triple combination control for damage and ensure that the sensor has been properly positioned.

- ◇ Check whether the burner malfunction control lamp on the automatic burner relay is illuminated.
- ◇ Release the automatic burner relay by pressing the malfunction button if the malfunction lamp lights up.  
*The malfunction light goes out and the burner tries to start.*
- ◇ Keep in mind that the units up to WKL 60 have a delayed start due to the oil preheating process.

## Important information about resetting the burner

- ◇ If, during the start phase, the unit is switched off again due to a malfunction, it may only be restarted after 5 minutes have elapsed.
- ◇ Take any steps necessary to prevent another reset.  
*Danger of deflagration.*

## The air supply fan does not start

- ◇ Set the operating switch to “Lüften” (fan) or “II”.  
*The air supply fan should now start.*
- ◇ Check that the fan and the fan drive are running smoothly.
- ◇ Check the V-belt on the fan drive.
- ◇ Check the electric cord on the fan motor for damage.
- ◇ Check whether the capacity of the fan was exceeded.  
*The thermal overcurrent relay (400 V series) or the thermal contacts (230 V series) in the fan motor have been activated.*
- ◇ Check the operating capacitor of the fan.  
*Only for the 230 V series.*
- ◇ Use suitable means to ensure that the fan control thermostat (TR) are functioning properly.

 **Please carry out an electrical safety test after having finished service on the unit.**

 **Should the unit still not function properly after performing these checks, please contact an authorised service centre.**

# Maintenance and Service

The operator must have the unit checked and serviced as necessary, at least once a year, by a representative of the manufacturing company or another authorised individual in accordance with the operating conditions.

 **Prior to doing any maintenance or repair work on the unit, unplug it from the power supply. It is not adequate to switch off the unit with the operating switch!**

 **Adjustments or maintenance work on the unit or forced-air burner may only be performed by authorised personnel!**

- ◇ Dust and dirt must be cleaned from the unit including from the heat-exchanger, combustion chamber and forced-air burner. Combustion residue in the combustion chamber and in the heat-exchanger must be removed.
- ◇ The V-belt tension and the motor mount must be checked on a regular basis.
- ◇ Parts that wear out, e.g. flue gas brakes, oil nozzles, oil filter inserts, seals etc. must be checked, cleaned and replaced if necessary.
- ◇ Make sure to comply with waste gas emission limits in accordance with regulations.

## Important Information on Servicing the Unit

- ◇ If the cleaning and burner adjustment intervals are not observed, the guarantee becomes null and void.
- ◇ It is therefore absolutely necessary to keep records that work has been performed by authorised personnel in addition to creating standard protocols.
- ◇ We recommend entering into a maintenance contract for the regularly scheduled maintenance and service work.

## Soot deposits

Even when there is only a small amount of soot buildup, the heating surfaces become insulated and the firing efficiency falls.

A 1 mm thick layer of soot causes an increase in the exhaust gas temperature of approx. 50 K (see diagram).

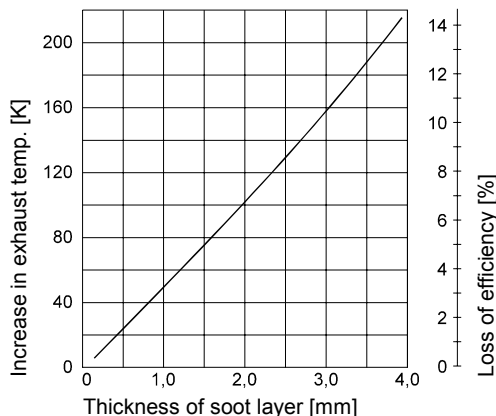

## Cleaning the Combustion Chamber and the Heat-Exchanger

1. Trennen Sie das Gerät vom Stromnetz.
2. Disassemble the following parts:
  - Burner with burner plate 12 (Shown Page 15)
  - Lining plate, front 14 (Shown Page 15)
  - Lining plate, top 3 (Shown Page 15)
  - Inspection cover, front 18
  - Exhaust gas connection 5.
3. Remove the flue gas brakes 20 from the heat-exchanger lines and clean the flue gas brakes. *Replace them if necessary!*
4. Clean the combustion residue from the heat-exchanger lines with a suitable cleaning brush.
5. Remove the accumulated combustion residue with a industrial vacuum cleaner from the front V and back H collection boxes. *A special cleaning set for the REMKO industrial vacuum cleaner can be purchased as an accessory.*
6. Clean the combustion residue from the furnace through the burner opening. *With cleaning brush and industrial vacuum cleaner.*

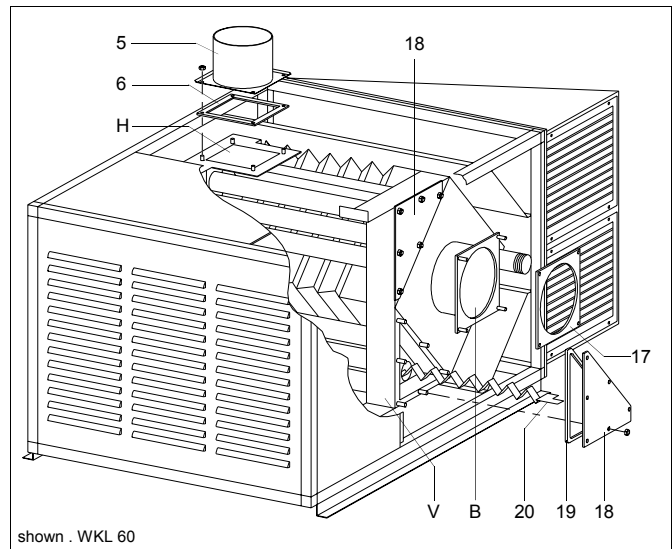

7. Reassemble all parts in the reverse order.
8. Make sure that the flue gas brakes are put back into the right place and that seals 6 + 17 + 19 and 13 (Shown Page 15) are positioned correctly. *Seals that have been damaged or malformed must be replaced.*
9. Attach the burner with burner plate. *Replace seal 17 if necessary.*
10. Service the burner in accordance with the separate operating instructions.

 **Check the burner and all regulating devices to ensure that they are functioning properly and set them to the optimum values.**

# Exploded View

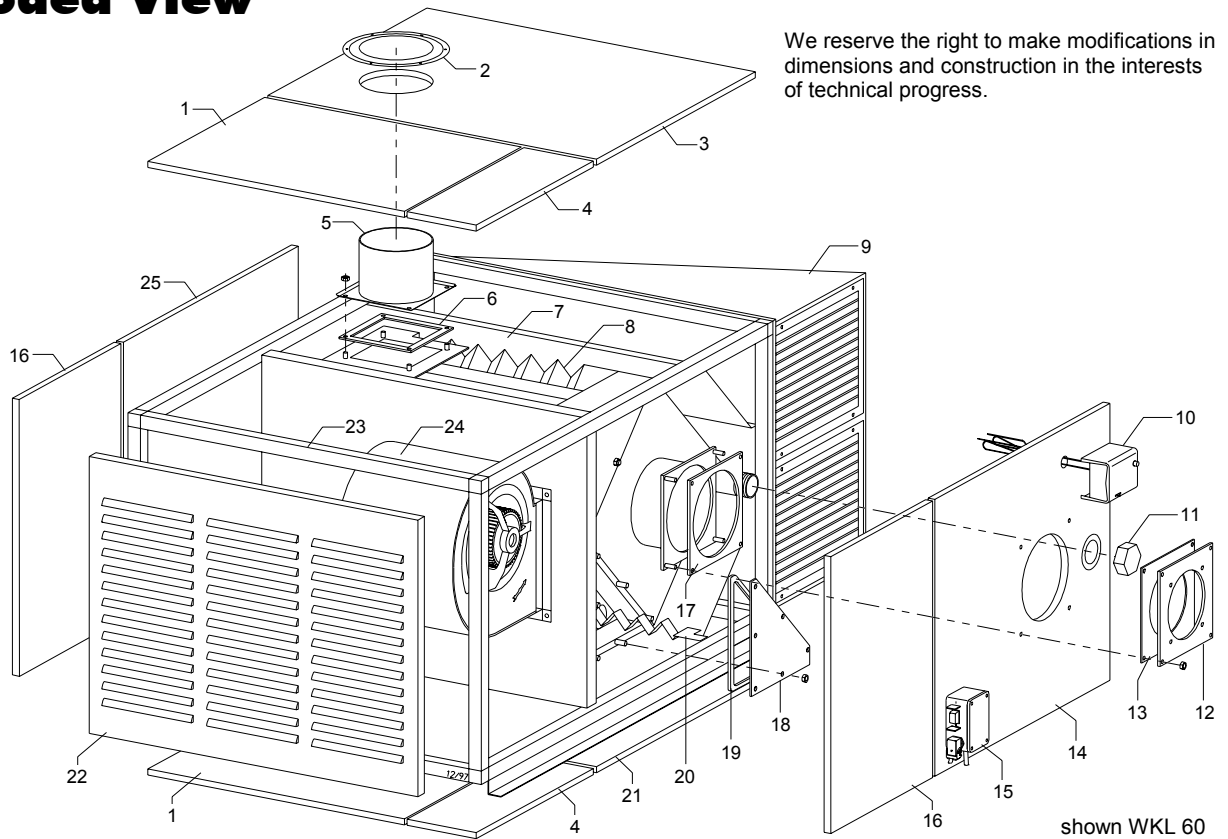

## Spare Part List

Pos.	Description	WKL 30 Ref. No.	WKL 60 Ref. No.	WKL 90 Ref. No.	WKL 120 Ref. No.
1	Lining plate	1102970	1102971	1102972	1102973
2	Rosette, exhaust gas connection	1103285	1103285	1103286	1103286
3	Lining plate, insulated	1102990	1102991	1102992	1102993
4	Lining plate	1103256	1103257	1103258	1103259
5	Exhaust gas connection	1103283	1103283	1103284	1103284
6	Seal for exhaust gas connection	1102947	1102947	1102947	1102947
7	Air guiding plate, side	1103180	1103181	1103182	1103182
8	Combustion chamber, cpl.	1103170	1103171	1103172	1103173
9	Blow out hood, cpl.	290172	291172	292172	293172
10	Triple combination control	1102572	1102572	1102572	1102572
11	Screw cap	1103219	1103220	1103220	1103220
12	Burner plate	1103235	1103236	1103236	1103236
13	Seal, burner plate	1102950	1102951	1102951	1102951
14	Lining plate, insulated	1103231	1103232	1103232	1103233
15	Control box, cpl.	1108380	1108380	292303	292306
16	Blind plate	1103238	1103239	1103239	1103240
17	Seal, combustion chamber flange	1102948	1102949	1102949	1102949
18	Inspection cover, front	1103245	1103246	1103247	1103248
19	Seal, running meter	1103255	1103255	1103255	1103255
20	Flue gas brake	1102953	1102954	1102955	1102956
21	Lining plate, insulated	1103210	1103211	1103212	1103213
22	Slotted plate, side	290109	291109	292109	293109
23	Unit frame, cpl.	1103200	1103201	1103202	1103203
24	Fan	1108423	1108602	1108600	1108550
25	Lining plate, insulated	1102994	1102995	1102996	1102997
-	Fan motor 400V / 3~/ N	—	—	1102768	1102766
-	Belt disc, motor	—	—	1102775	1102770
-	Belt disc, fan	—	—	1102776	1102780
-	V-belt	—	—	1102779	1102773

**When ordering spare parts please indicate ref. no. and machine no. (see model plate)!**

# Wiring Diagram 230 V

Fan motor: 230 V / 1~

Burner motor: 230 V / 1~

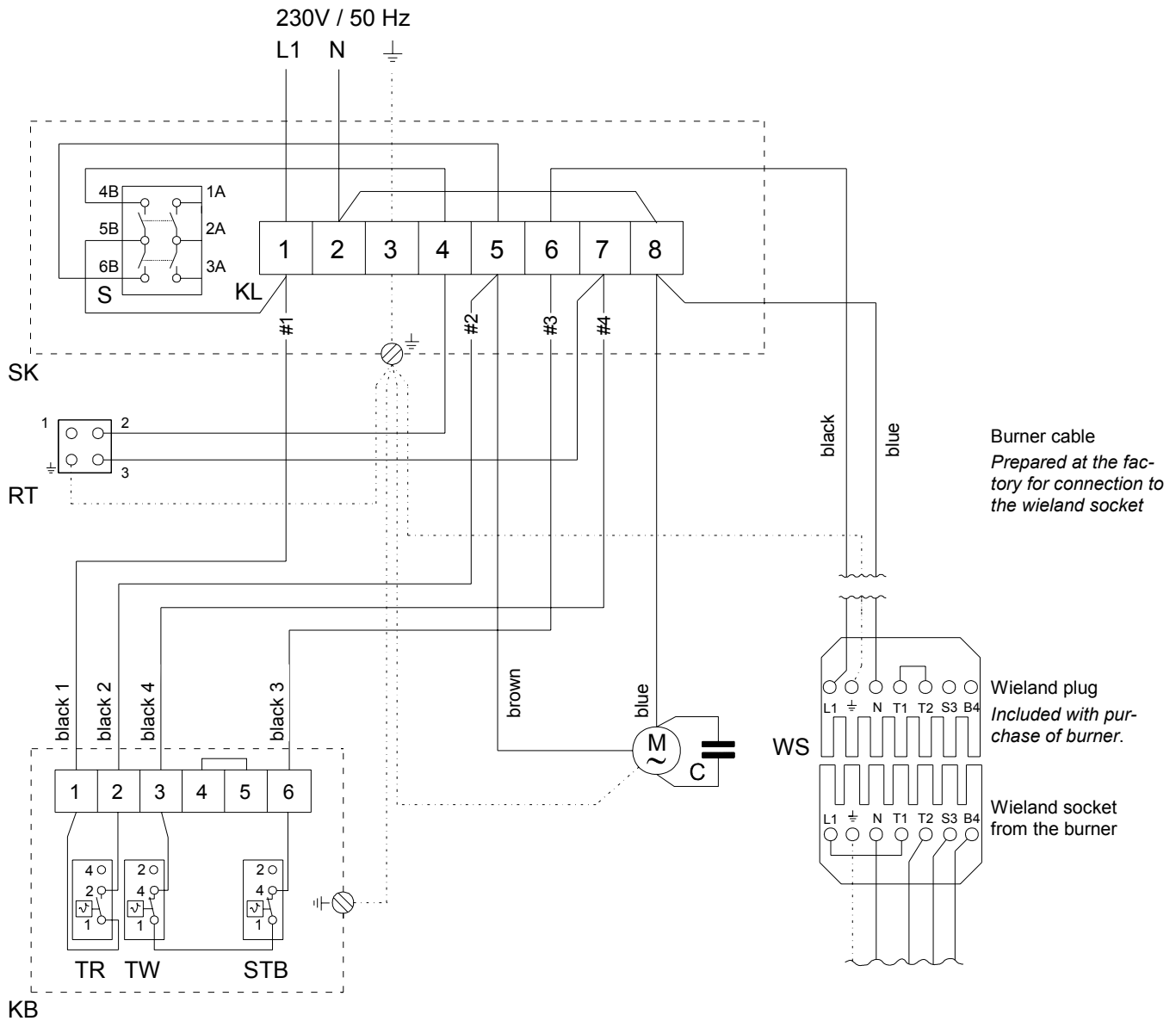

- C Capacitor
- KB REMKO Triple Combination Control
- KL Terminal strip in the control box
- M Fan motor
- RT Thermostat socket
- S Operating switch
- SK Control box
- STB Safety temperature limiter
- TR Fan control thermostat
- TW Temperature monitor
- WS Wieland plug  
(Only for factory-installed burner)

An easily accessible emergency switch must be attached in the setup room, but not close to hazardous areas.

This switch must be protected from damage and unauthorised use!



**The electrical connections should only be made by authorised personnel.**

We reserve the right to make modifications in dimensions and construction in the interests of technical progress.

# Wiring Diagram 400 V Direct Start

Fan motor: 400 V / 3~ (up to 2,2 kW)

Burner motor: 230 V / 1~

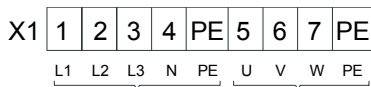
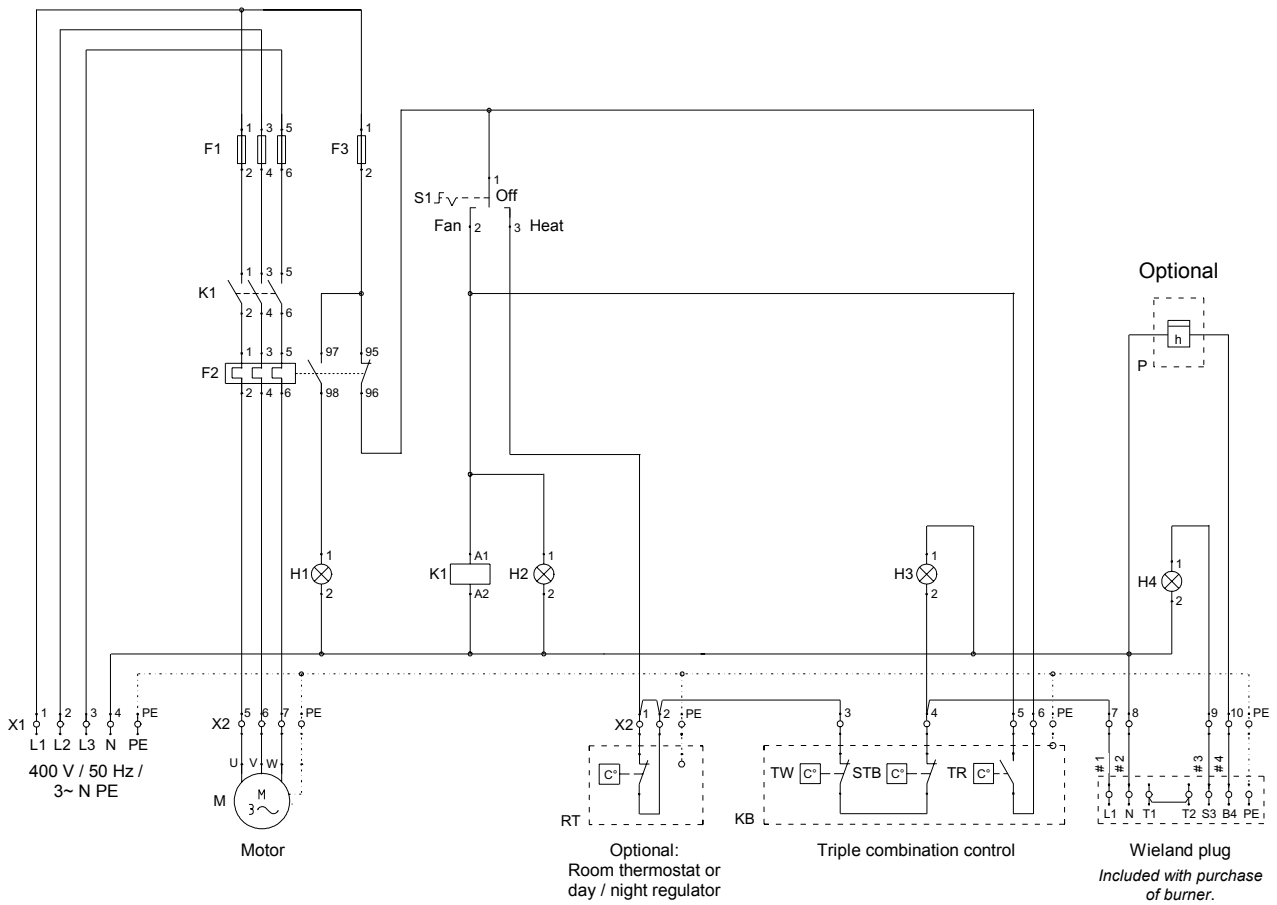

If a room thermostat or a day/night control mechanism is connected, the factory-installed bridge between terminals 1 and 2 of the terminal strip X2 must be removed.

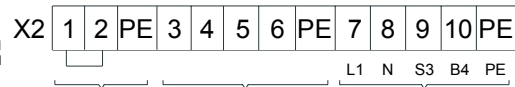

Supply line

Fan motor

Room thermostat or day / night regulator

Triple combination control

numbered burner cable  
Prepared at the factory for connection to the Wieland socket

- F1 Fuse block, fan motor
- F2 Thermal overcurrent relay, fan motor
- F3 Control fuse
- H1 Malfunction lamp, fan
- H2 Operating lamp, fan
- H3 Operating lamp, burner
- H4 Malfunction lamp, burner
- K1 Contactor, fan motor
- KB REMKO triple combination control
- M Fan motor
- P Running hour meter (optional)

- RT Room thermostat or regulator (optional)
- S1 Operating switch
- STB Safety temperature limiter
- TR Fan control thermostat
- TW Temperature monitor
- X1 Terminal strip 1 in the control box
- X2 Terminal strip 2 in the control box



**The electrical connections should only be made by authorised personnel.**

We reserve the right to make modifications in dimensions and construction in the interests of technical progress.

# Technical Data

REMKO WKL		30	60	90	120
Rated heat power	kW	33	62	89	125
Rated heat output	kW	29	57	82	115
Rated air output <sup>1)</sup>	m <sup>3</sup> /h	1990	4450	6100	8490
Fuel		Heating oil EL			
Oil throughput max.	kg/h	2,8	5,2	7,5	10,5
Exhaust mass current V <sub>Af</sub> <sup>2)</sup>	kg/h	52	97	140	198
Exhaust temperature approx. <sup>3)</sup>	°C	180-195	180-195	180-195	180-195
Required chimney draught	Pa	0	0	0	0
Exhaust loss V <sub>A</sub> max.	%	9	8	8	8
Furnace resistance approx.	Pa	22	28	39	38
Electrical connection	V	230 / 1~	230 / 1~	400 / 3~ N	400 / 3~ N
Frequency	Hz	50	50	50	50
Rated current <sup>4)</sup>	A	2,2	4,5	2,8	3,7
Power consumption <sup>4)</sup>	kW	0,25	0,52	1,1	1,5
Power consumption <sup>5)</sup>	kW	0,21	0,21	0,45	0,45
Sound pressure level L <sub>pA 1m</sub> <sup>6)</sup>	dB(A)	57	58	63	60
Exhaust gas connection Ø	mm	150	150	180	180
Weight <sup>4)</sup>	kg	165	258	335	385
Dimensions:					
Length, over-all	mm	1570	1870	2070	2270
Height, without exhaust connection	mm	630	830	830	930
Depth, without burner	mm	850	1000	1250	1250

- 1) Air current at  $\Delta t$  45 K / 1,2 kg/m<sup>3</sup>
- 2) Approx. quantity for Heating oil EL
- 3) Measured temperature minus room temperature
- 4) Unit without burner
- 5) For manufacturer-supplied burner
- 6) Noise measuring (without burner) DIN 45635-01-KL3

**Max. suction temperature 40 °C / max. outgoing temperature 100 °C**

# Maintenance Log

**Model:** : ..... **Model No.:** : .....

**Burner** : ..... **Burner No.:** : .....

	1	2	3	4	5	6	7	8	9	10	11	12	13	14	15	16	17	18	19	20
Clean unit -surface-																				
Clean unit -interior-																				
Clean fan																				
Clean combustion chamber																				
Clean heat exchanger																				
Clean/replace waste gas suppressor																				
Replace seals -inspection cover-																				
Replace seals –burner-																				
Clean/replace filter -fuel-																				
Check safety mechanisms																				
Electric safety inspections																				
Check protective mechanisms																				
Check unit for damage																				
Maintenance –burner																				
Test run																				

Remarks: .....  
 .....

1. Date: ..... ..... Signature	2. Date: ..... ..... Signature	3. Date: ..... ..... Signature	4. Date: ..... ..... Signature	5. Date: ..... ..... Signature
6. Date: ..... ..... Signature	7. Date: ..... ..... Signature	8. Date: ..... ..... Signature	9. Date: ..... ..... Signature	10. Date: ..... ..... Signature
11. Date: ..... ..... Signature	12. Date: ..... ..... Signature	13. Date: ..... ..... Signature	14. Date: ..... ..... Signature	15. Date: ..... ..... Signature
16. Date: ..... ..... Signature	17. Date: ..... ..... Signature	18. Date: ..... ..... Signature	19. Date: ..... ..... Signature	20. Date: ..... ..... Signature

**Maintenance work may only be performed by authorised personnel; settings must comply with legal specifications. A corresponding test log must be kept.**

**REMKO GmbH & Co. KG**

Klima- und Wärmetechnik

D-32791 Lage · Im Seelenkamp 12

D-32777 Lage · PO Box 1827

Phone +49 (5232) 606 - 0

Fax +49 (5232) 606260

E-Mail: [info@remko.de](mailto:info@remko.de)

Internet: [www.remko.de](http://www.remko.de)