

REMKO



3-WAY SWITCHING VALVE DN 32

Operation · Technology



REMKO 3-WAY SWITCHING VALVE DN32

Safety notes

Carefully read the operating instruction before placing the equipment in service. It contains useful tips  and notes  such as hazard warnings to prevent injury and material damage. Failure to follow the directions in this manual can result in endangerment to persons, the environment and the equipment itself and will void any claims for liability.

- Keep this manual in the vicinity of the unit.
- The unit should be set up and installed only by qualified personnel.
- The set-up, connection, and operation of the unit and its components must be in accordance with the operating conditions stipulated in this manual and comply with all applicable local regulations.
- Modification of equipment and components supplied by REMKO is not permitted and can cause malfunctions.
- Equipment and components may not be operated in areas where there is an increased risk of damage. Observe the minimum clearances.
- The electrical supply is to be adapted to the requirements of the equipment.
- The operational safety of equipment and components is only assured if they are fully assembled and used as intended. Safety devices may not be modified or bypassed.
- Do not operate equipment or components with obvious defects or signs of damage.
- The equipment and components must be kept at a safe distance from inflammable, explosive, combustible, aggressive and dirty areas or atmospheres.
- Installation, repair and maintenance work may be carried out only by authorised specialists. Visual inspections and cleaning can be performed by the operator as long as power is disconnected from the equipment.
- To preclude any danger from the equipment, take appropriate hazard-prevention measures when performing installation, repair or maintenance work or cleaning the equipment.



Environmental protection and recycling

Disposal of packaging

All products are packed for transport in environmentally friendly materials. Make a valuable contribution to reducing waste and sustaining raw materials. Only dispose of packaging at approved collection points.

Disposal of components



Equipment manufacture is subject to continuous quality control. Only high-grade materials are processed, the majority of which are recyclable. You can also contribute to environmental protection by only disposing of components in accordance with local regulations and in an environmentally safe manner, e.g. through authorised disposal and recycling specialists or at collection points.

Guarantee

The guarantee conditions are listed in the "General terms and conditions". Please contact your contractual partner in the first instance.

Description

The 3-way switching valve controls the flow of process water or a separate cooling circuit (four pipe system).

It is comprised of an electrical actuator and a hydraulic lower section, the actual valve.

Through its design the brass forged 3-way switching valve allows a redirection of the medium, almost entirely independent of the differential pressure. The rotary valve of the 3-way switching valve is equipped with replaceable, glycol-resistant O-rings. The 3-way switching valve is normally controlled using an electric actuator. During the installation work and especially for the bleeding of the heating system or for inspection purposes, the 3-way switching valve can also be operated manually. For this purpose the electric actuator must be removed.

The housing consists of corrosion-resistant brass.

The connections have a 5/4" inside thread on both the inlet and outlet sides.

REMKO 3-WAY SWITCHING VALVE DN32

Operation

Mode of operation

At REMKO the flow direction AB must be open to B in resting position of the 3-way switching valve. This corresponds to the heating flow direction. The correct position of the axis and the actuator of the 3-way switching valve must absolutely be checked before installation. In the lower figure you can see the correct position of the axis and the actuator. If the part which you have on hand does not match this figure precisely, proceed according to the modification instructions (text) of the lower figure.

The flow direction of AB to A corresponds to the hot water charging position or cooling mode when used as a "cooling" switching valve in a 4-pipe system.

The reversal between the two flow directions takes approx. 18 seconds.

Flow direction and its change, if applicable

Ändern der Durchflußrichtung
A/B<>B bei Relais-Ruhestellung.

Beide Kugelkopfschrauben M6
herausdrehen und 90°versetzt
wieder eindrehen.

Drehschieber in die
gew. Grundpos. bringen.
Antrieb aufsetzen, und
nach Abschluß der Montage
Fixierschraube -2- festdrehen.
Deckel mit Schraube -1- sichern.
-Funktionskontrolle-

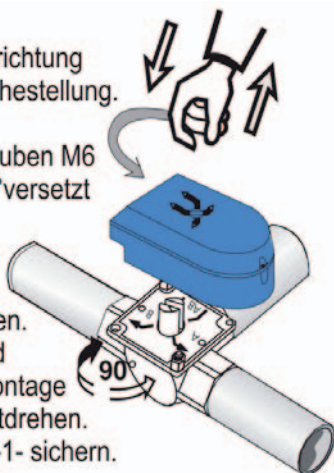

Heating mode flow direction

Initial situation (resting position): Flow direction: AB<->B

Valve in position AB<->B
(Heat pump in heating mode)



Actuator in position A<->A
(A for "initial situation")



Hot water charging mode or cooling mode flow direction

... after actuation: Flow direction: AB<->A

Valve in position AB<->A
(Heat pump in hot water or
in cooling mode)



Actuator in position B<->B
(B for "actuated")



ATTENTION

Before installation, make sure of the correct position of the valve axis (if necessary, rotate the axis, indicator plate and spherical head screws 90° in accordance with the top figure!

REMKO 3-WAY SWITCHING VALVE DN32

Installation



NOTE

Installation may only be performed by authorised specialists.



NOTE

Do not use any boiler accessories, soldering material or wet materials of a mineral oil basis, mineral oil or hydrocarbon.



ATTENTION

Pay attention to the flow direction before installation. (Correct position of the axis and installation position in accordance with the REMKO hydraulic diagram.)

- Pay attention to the installation position and the correct position of the axis of the 4-way switching valve.
- Only fit the actuator and make electrical connection to the heat pump manager after completion of all hydraulic installation work and successful leak test.
- Allow for sufficient space for the 3-way switching valve. In the process, also plan for sufficient space for the pipe insulation. That is important on the one hand for the problem-free fitting of the actuator and on the other hand for any later maintenance work.

Mounting

The installation is basically independent of the position. However, the actuator should not be installed "face-down", as far as possible.

- The 3-way switching valve and the actuator are loosely fit together in the condition as supplied. At first, leave the actuator in the package and begin with the hydraulic installation of the 4-way switching valve.

Mounting the actuator

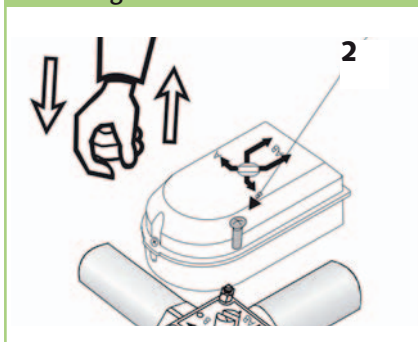

Electrical connection



ATTENTION

All electrical installation work is to be performed by specialty companies. Disconnect the voltage supply when connecting the electrical terminals. Observe the VDE guidelines.

- Limit switches are integrated in the actuator of the 3-way switching valve.
- The actuator requires a continuous operating voltage of 230V/1~/50Hz. This must be connected to the brown (L) and blue (N) wires. In this state the valve is in resting position. This corresponds to heating position and/or opening of the path AB<->B.

- The valve is actuated if the black wire of the actuator is additionally connected to a voltage of 230V/1~/50Hz. The valve then turns 90 °C until it reaches the limit switch. This, in turn, corresponds to the hot water or cooling position and/or opening of the path AB<->A. The valve remains in this state until the voltage is disconnected from the black wire again.

- Every heat pump has appropriately labelled connection terminals for the connection of the actuator.



NOTE

Observe the instructions in the installation manual of the heat pump for the correct connection. (Connection diagram and circuit diagrams, if applicable)

Actuator connection diagram

Ansteuerung: 2 Punkt-Steuersignal mit " Dauerphase"

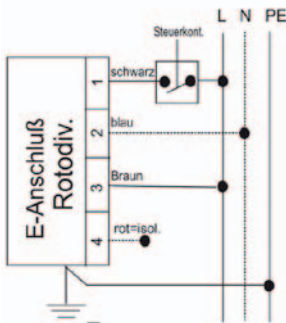

Schwarz: liegt Steuerphase -L-(230V~) an, so öffnet der Weg A/B<>B (je nach Pos.)
Liegt kein Steuersignal. an, wird das Ventil wieder in die Ausgangslage zurückgestellt..A/B<>A

Braun: Dauerphase -L-(230V~)
-muß ständig anliegen.-

Blau: = Nulleiter -N-(230V~)

Rot: = ES-Ausgangssignal, (isoliert)

REMKO 3-WAY SWITCHING VALVE DN32

Manual mode

The 3-way switching valve can be operated manually until the time of commissioning or in case of a defect of the actuator. The electrical actuator must be removed in this case.

To do so, proceed as follows:

1. Loosen fastening screw "2" of the actuator. This is under the black cover. Then you can remove the actuator.
2. The 4-way switching valve can be moved to the desired position using a large screwdriver. This must be able to take place smoothly and easily. Otherwise the valve must be replaced, cleaned and/or repaired.

⚠ ATTENTION

The replacement of the actuator must take place in a de-energised (electrical) state. Also disconnect the main connection to the actuator.

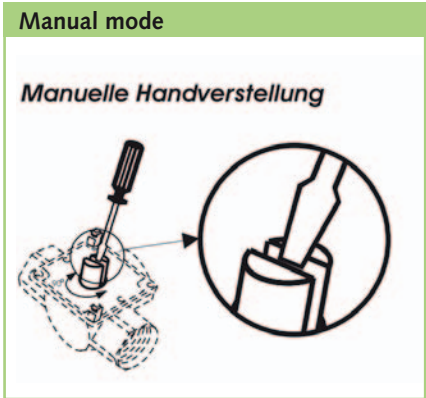
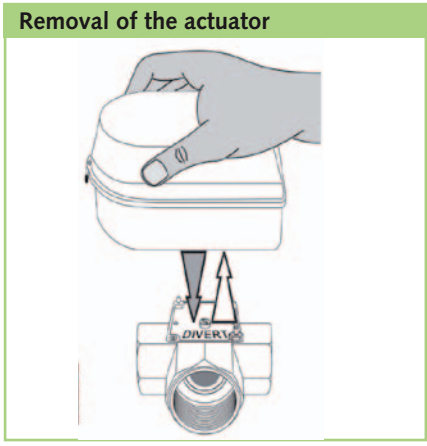
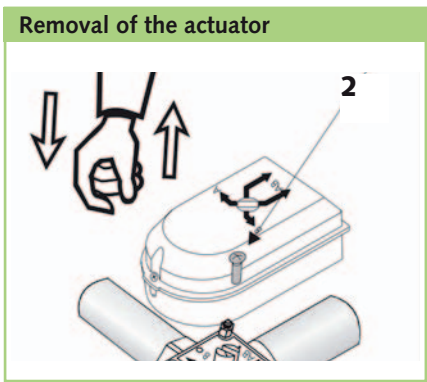

Unit dimensions

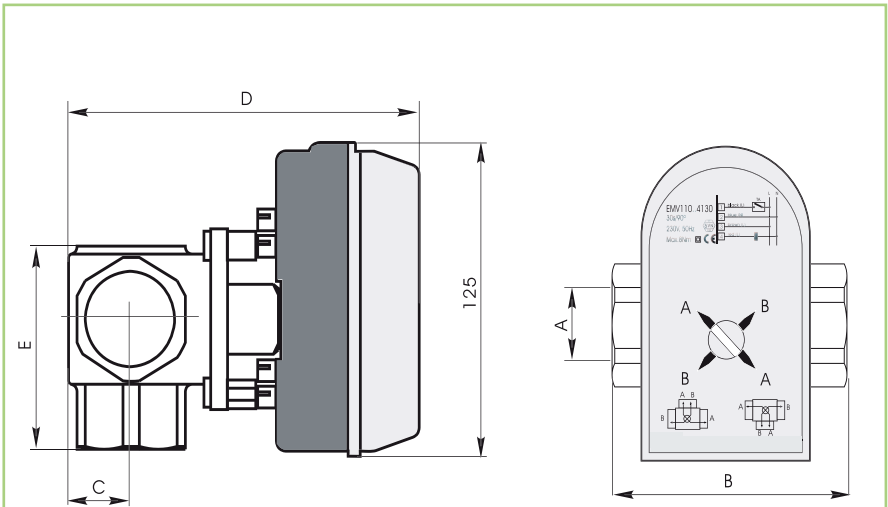

Measurement A	Measurement B	Measurement C	Measurement D	Measurement E
DN 32	90 mm	24 mm	122 mm	69 mm

We reserve the right to modify the dimensions and constructional design as part of the ongoing technical development process.

Pressure loss diagram

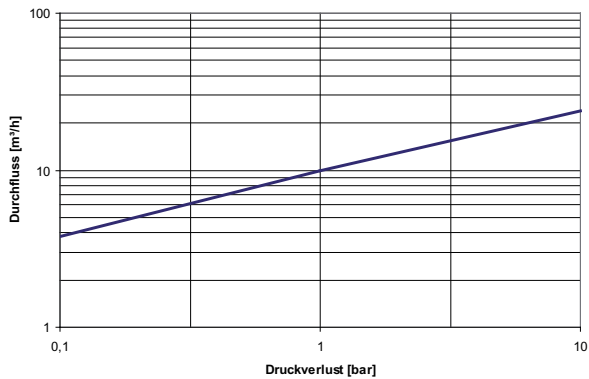

REMKO 3-WAY SWITCHING VALVE DN32

Technical data

Unit type		3-way switching valve
Cvs value (pressure loss 1 bar)	m ³ /h	10
Max. operating temperature	°C	110
Max. operating pressure	bar	6
Max. differential pressure	bar	0,4
Switching time	s	18
Medium connectors	Inches (")	5/4 IG
Lower valve section torque	Nm	0,5
Max. actuator torque	Nm	8
Electrical connection	V	230/1~N
Frequency	Hz	50
Power consumption in resting position	VA	3
Power consumption during operation	VA	7,5
Voltage resistance of the limit switch	A/V/Hz	5(1)/250/50
Connection line length	mm	2000
Connection line conductor cross-section	mm ²	4 x 0.5
Permissible environmental temperatures	°C	0-60
Protection class according to EN 60355-1	-	Class II (insulated)
Protection class according to IEC 529	-	IP 44
Weight	kg	1,37
Nominal width	DN	32
EDP No.		260075

We reserve the right to modify the dimensions and constructional design as part of the ongoing technical development process.

Exploded drawing and spare parts list

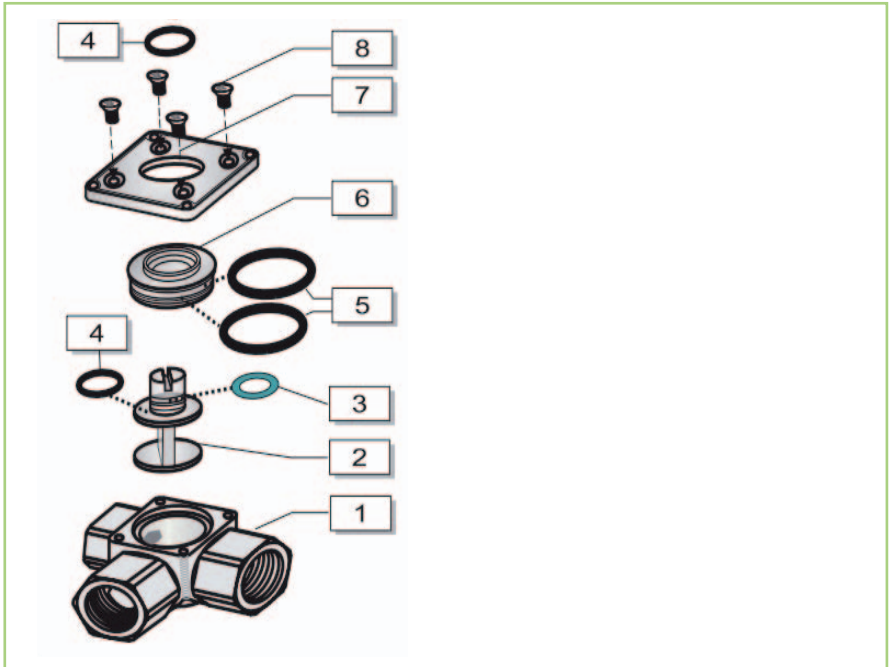

No.	Designation	EDP No.
1	Valve body	1120270
2	Flap with axis	1120271
3	O-ring 8.73x1.78	1120272
4	O-ring 11.91x2.62	1120273
5	O-ring 23.3x2.4	1120274
6	Insert	1120275
7	Valve cover	1120276
Without figure		
	Actuator	1120277
	Indicator plate	1120278

REMKO INTERNATIONAL

*... and also right in your neighbourhood!
Make use of our experience and advice*



REMKO GmbH & Co. KG
Air conditioning and heating technology

Im Seelenkamp 12 · D-32791 Lage

Postfach 1827 · D-32777 Lage

Telephone +49 5232 606-0

Fax +49 5232 606-260

E-mail info@remko.de

Website www.remko.de

