

REMKO

4-WAY SWITCHING VALVE

Installation · Operation · Technology



Contents

<i>Safety instructions</i>	4
<i>Environmental protection and recycling</i>	4
<i>Warranty</i>	5
<i>Description</i>	5
<i>Operation</i>	6
<i>Installation</i>	7-9
<i>Electrical connection</i>	9
<i>Electrical connection diagram</i>	10
<i>Technical data</i>	11
<i>Spare parts list</i>	11

Read this installation manual carefully before commissioning / using these units!

This manual is an integral part of the unit and must always be kept in the vicinity of the installation location or on the unit itself.

This operating manual is a translation of the German original.



Subject to modifications; no liability accepted for errors or misprints!



Made by REMKO

REMKO FOUR-WAY SWITCHING VALVE

Safety instructions

Carefully read the operating manual before placing the unit in service for the first time. It contains useful tips and  notes such as  hazard warnings to prevent injury and material damage. Failure to follow the directions in this manual can result in endangerment to persons, the environment and the equipment itself and will void any claims for liability.

- Keep this manual in the vicinity of the units.
- The units and components should be set up and installed only by qualified personnel.
- The set-up, connection, and operation of the unit and its components must be in accordance with the operating conditions stipulated in this manual and comply with all applicable local regulations.
- Modification of units and components supplied by REMKO is not permitted and can cause malfunctions.
- Units and components may not be operated in areas where there is an increased risk of damage. Observe the minimum clearances.
- The electrical supply is to be adapted to the requirements of the units.
- The operational safety of units and components is only assured if they are fully assembled and used as intended. Safety devices may not be modified or bypassed.
- Do not operate units or components with obvious defects or signs of damage.

- The units and components must be kept at a safe distance from inflammable, explosive, combustible, aggressive and dirty areas or atmospheres.
- Installation, repair and maintenance work may be carried out only by authorised specialists. Visual inspections and cleaning can be performed by the operator as long as power is disconnected from the equipment.
- To preclude any danger from the unit, take appropriate hazard-prevention measures when performing installation, repair or maintenance work or cleaning the units.



Environmental protection and recycling

Disposing of packaging

All products are packed for transport in environmentally friendly materials. You can make a valuable contribution to reducing waste and sustaining raw materials by only disposing of packaging at approved collection points.

Disposal of components

The manufacturing process for the units is subject to continuous quality control. Only high-grade materials are processed, the majority of which are recyclable. You can also contribute to environmental protection by only disposing of components in accordance with local regulations and in an environmentally safe manner, e.g. through authorised disposal and recycling specialists or at collection points.



Warranty

The warranty conditions are listed in the "General terms and conditions". Please contact your contractual partner in the first instance.

Description

The four-way switching valve serves to incorporate a boiler into systems (the hydraulic diagram pictured below is an example). It is comprised of an electrical actuator and a hydraulic lower section.

Due to its shape, the installed cylindrical

gate valve allows the medium to be re-directed in a way which is not dependent on the differential pressure. This gate valve is controlled by an actuator.

The gate valve can also be operated manually via a lever located on the plastic housing. This makes it possible to also operate the four-way switching valve by hand, without the electric motor.

The housing consists of corrosion-resistant gunmetal (bronze).

The connections have a 5/4" inside thread on both the inlet and outlet sides.

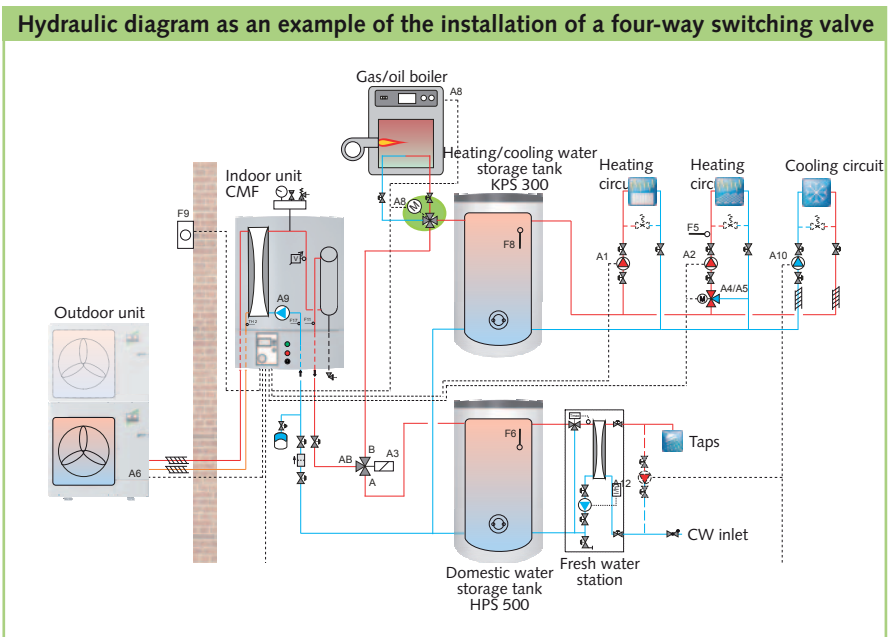

REMKO FOUR-WAY SWITCHING VALVE

Operation

Mode of operation

All the moving parts and all valve gaskets are incorporated into a cartridge.

The outer surface of the piston has O-rings which guarantee that the paths are hermetically sealed.

If the valve rod is moved to position I, the flow passes through the openings of the cylindrical gate valve, taking the route "A" and "B" and "C" and "D".

If, on the other hand, the valve rod is in position II (outlet position), then the flow takes route "A" and "D" and "B" and "C".

The switching process and the running time for 90° is 60 seconds. The valve can be adjusted manually using the supplied rotary knob.

Manual actuation of the valve is useful whenever the line system is being refilled, drained or bled, but also if the electric motor is no longer functional (e.g. due to power failure).

When the four-way switching valve is reconnected to the power supply after a power cut, the actuator and the valve return automatically to the normal position.

Valve position

Valve position I
(only heat pump in operation):
Switch position: A<->B and C<->D

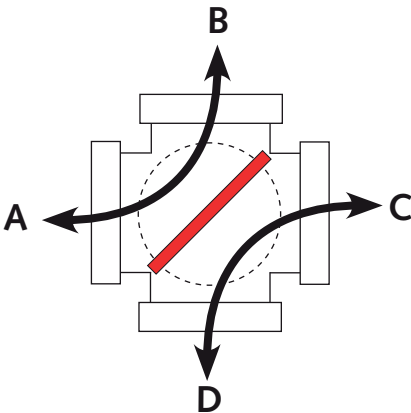

Valve position II
(bivalent mode):
Switch position: A<->D and B<->C

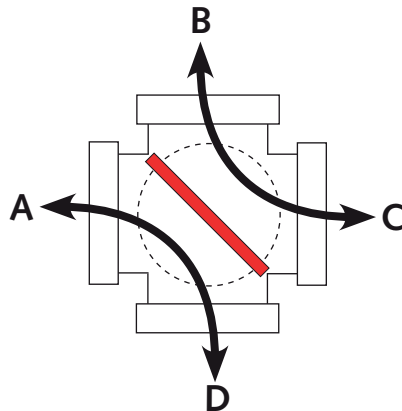

Installation



NOTE

Installation may only be performed by authorised specialists.



NOTE

Do not use any boiler accessories, soldering material or wet materials of a mineral oil basis, or which contain mineral oil, hydrocarbon or ethylene glycol acetate. If diluted with at least 50% water, diethylene glycol, ethylene glycol and propylene glycol can be used (anti-freeze agent).

Installation

The unit can be installed basically independent of position. However, wherever possible, the actuator should not be installed upside down.

Orientation for installation

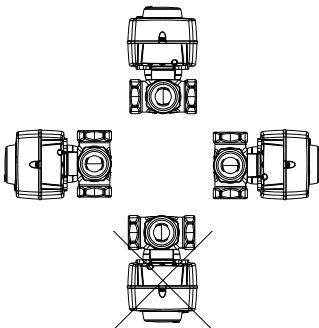

The four-way switching valve is comprised of an electrical actuator and a hydraulic lower section.

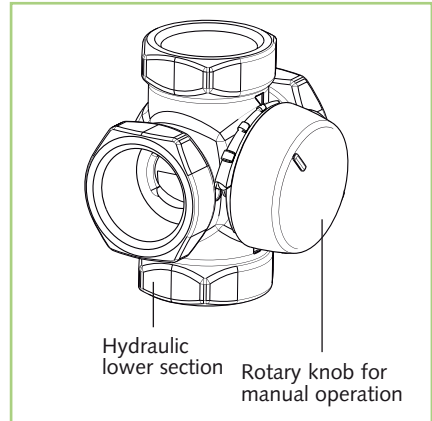

- Install the hydraulic lower section in the heat distribution system in accordance with the hydraulic diagram. Use the appropriate transitions for the connection threads with 5/4" internal thread and suitable sealing material.
- In order to bleed and carry out a function check on the system, we first recommend operating the system manually.

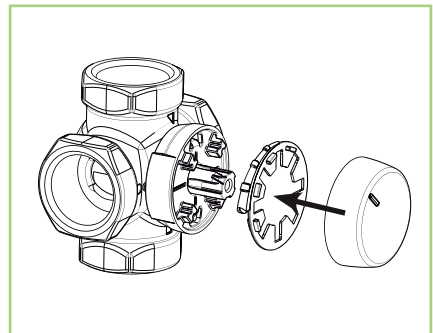

REMKO FOUR-WAY SWITCHING VALVE

After installation is complete and the subsequent leak test has been performed, the actuator must be attached to the lower section.

CAUTION

All connections must be made with the unit in a de-energised state (electrical system).

- To do this, remove the rotary knob used for manual operation.

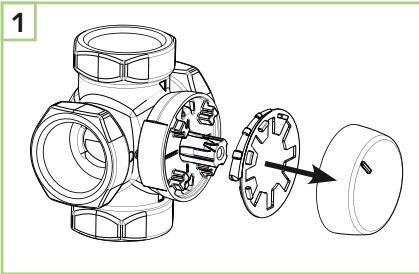

- Then insert the supplied plastic coupling piece on to the axle of the hydraulic lower section.

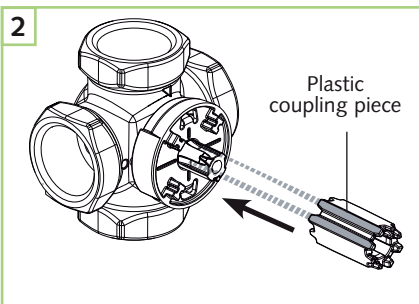

- Attach the first of the two supplied indicators for the direction of rotation on the front of the actuator above the rotary knob. To do this, remove the rotary knob of the actuator.

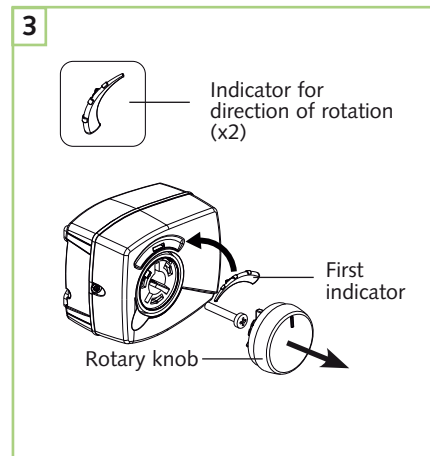

- Attach the second indicator to the back of the actuator.

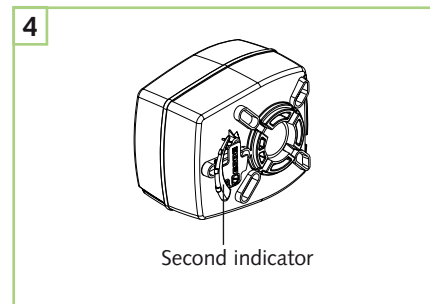

Electrical connection

- Then screw the actuator on to the hydraulic lower section.

5

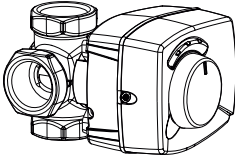

CAUTION

Perform the function check by operating the unit manually, before completing the electrical connection! (To do this, proceed as described further down!)

Manual mode

For maintenance and/or servicing work when the actuator has already been fitted, the four-way switching valve can be operated manually for inspection purposes.

- To do so, simply pull out the rotary knob until it comes detached. The four-way switching valve can then be moved into any position by hand.

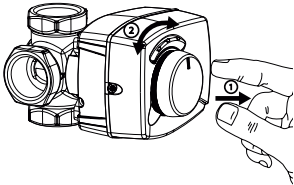

NOTE

Installation may only be performed by authorised specialists.



CAUTION

All electrical installation work is to be performed by specialist companies. Disconnect the power supply when connecting the electrical terminals.

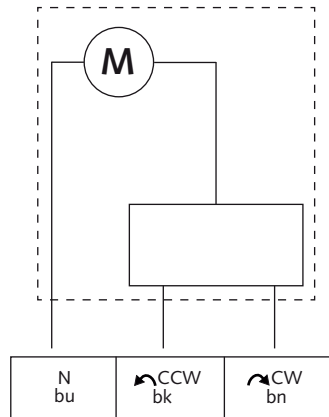

NOTE

The servo motor has one limit switch each at both of the left and right stops for shutdown purposes.

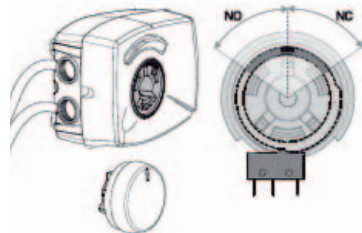

REMKO FOUR-WAY SWITCHING VALVE

Electrical connection diagram CMF/CMT 120/160

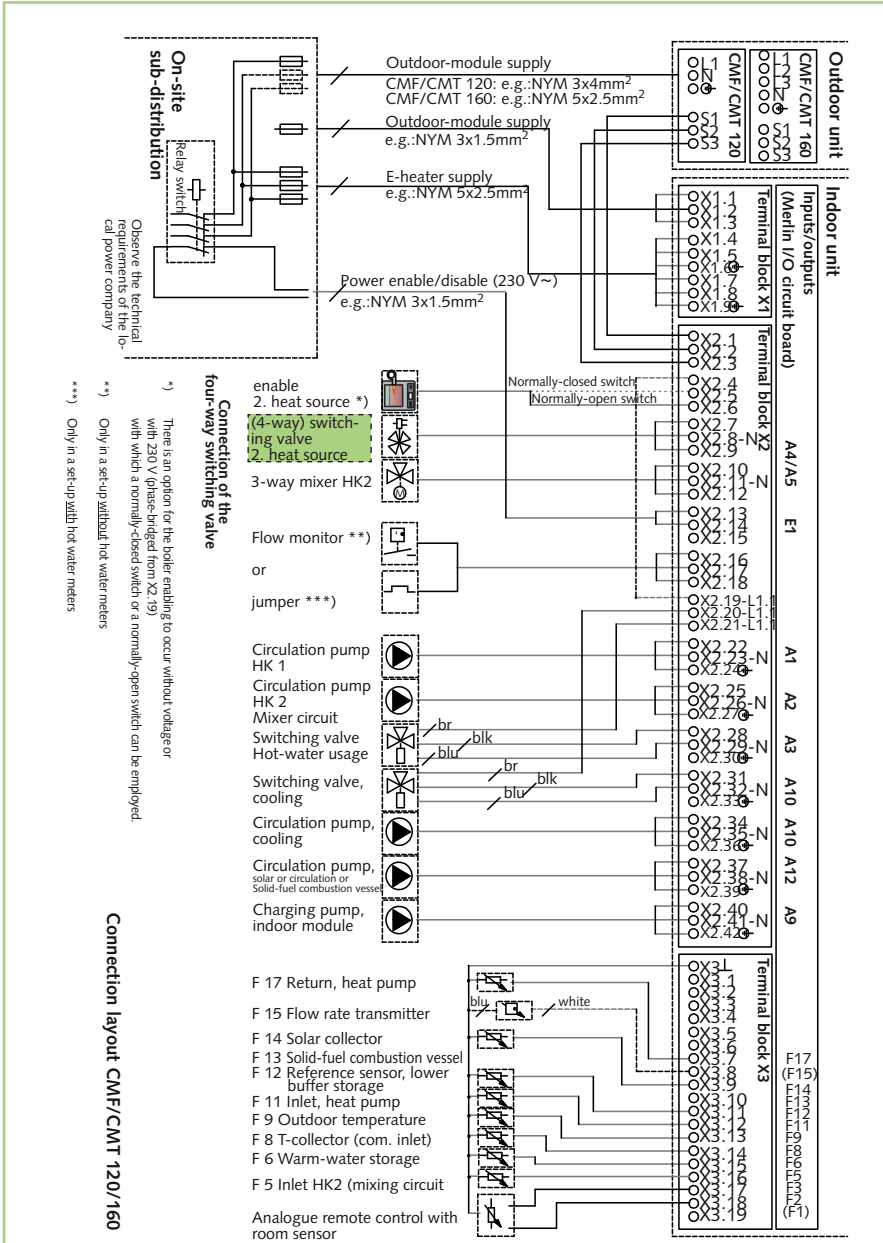

Technical data

Unit type		Four-way switching valve
Cvs value (pressure loss 1 bar)	m ³ /h	8
Nominal pressure	bar	10
Max. differential pressure	kPa	400
Running time 90°	s	60
Medium connectors	Inches	5/4" internal thread
Electrical connection	V	220-240/1~N
Protection class		IP41
Frequency	Hz	50-60
Max. torque	Nm	6
Power consumption	W	4
Apparent output	VA	5
Current capacity of the auxiliary contacts	A/V	3/250
Connection line length	mm	1000
Permissible ambient temperatures	°C	-10 - +65
Min./max. heating water temperatures	°C	1-95
Nominal diameter	DN	32
EDP no.		260071

We reserve the right to modify the dimensions and constructional design as part of the ongoing technical development process.

Spare parts list

No.	Description	EDP no.
1	Actuator for four-way switching valve	1120181
2	Hydraulic lower section, 5/4"	1120182

REMKO INTERNATIONAL

*...and right in your own location too!
Benefit from our experience and advice*



REMKO GmbH & Co. KG **Air conditioning and heating technology**

Im Seelenkamp 12
Postfach 1827
Telephone
Fax
e-mail
Website

D-32791 Lage
D-32777 Lage
+49 5232 606-0
+49 5232 606-260
info@remko.de
www.remko.de

