

REMKO OLB

Forced-Air Oil Burner

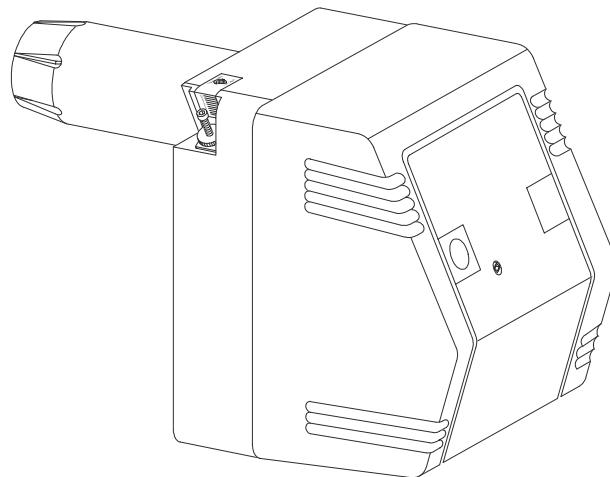

Operation
Technology
Spare Parts

Operating Instructions for the Operator Assembly and Service Instructions for the Installer

Read these instructions carefully before setting up/operating this oil burner!

Our guarantee becomes null and void if the unit is used, set up or maintained improperly, or if modifications are made to the supplied unit without our prior consent.

**Forced-air oil burner
for use with
REMKO heaters**

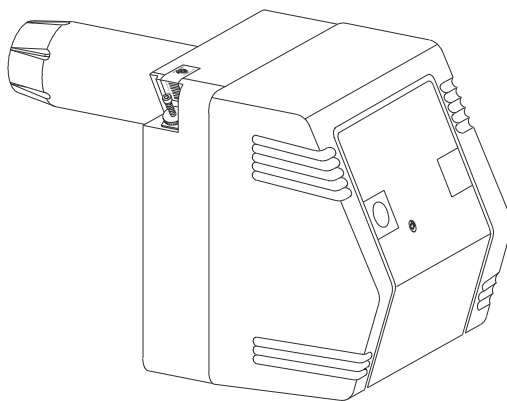

Contents	Page	Contents	Page
Safety Hints	4	Exploded View	12
Description of Device	4	Spare Parts List	13
Assembling the Oil Burner	5	Troubleshooting	14
Initial Operation	5	Measurement and Service Log	15
Adjusting the Air Flap	8	Service Instructions	15
Wiring Diagram	10		



**Always keep these operating instructions
near or on the unit.**



Safety Hints

The forced-air oil burner has been manufactured in accordance with the technical requirements at the time of supply.

Extensive tests have been conducted on the material, functionality and quality of the forced-air oil burner to ensure that it is a high-performance unit with a long service life.

Hazards may nevertheless arise if the unit is used by persons not familiar with its operation or if the unit is not used for its intended purpose.

You must follow the instructions below:

- ◇ The operator is responsible for ensuring proper assembly and safe operation.
- ◇ Assembly, fuel connection, electrical connection and maintenance may only be performed by trained personnel in accordance with the applicable regulations.
- ◇ Only operate the forced-air oil burner when assembled.
- ◇ Safety mechanisms, such as protective grilles or covers, may not be disassembled or taken out of operation.
- ◇ Only operate the forced-air oil burner for its intended purpose and within the specified capacity limits.
See type plate and technical data.
- ◇ The protective air suction grille must always be kept free of dirt and loose objects.
- ◇ The forced-air oil burner may not be exposed to a direct stream of water.
High-pressure cleaners, etc.
- ◇ When using the burner outside, appropriate measures must be undertaken to prevent moisture from getting inside the unit.
- ◇ All electrical cords outside the unit are to be protected from damage (e.g. caused by animals, etc).

 **Before performing any maintenance or repair work, make sure to unplug the burner from the power supply!**

Description of Device

This forced-air oil burner which is specially designed for use with warm air generators is particularly easy to use and service, and is very reliable.

The forced-air oil burner is safe to operate and meets the relevant EU regulations.

- ◇ An Allen key is necessary to perform almost all maintenance work.
- ◇ A standard 7-pin plug is used for the electrical connection to the warm air generator.

- ◇ The oil preheater (up to model size 33 in this series) heats viscous oil automatically to the correct atomisation temperature.
Nozzle capacity and atomisation remain constant.
- ◇ The optimum burner pressure can be set depending on the local conditions using the gradually adjustable air intake nozzle.
The intake diameter is not reduced.
- ◇ The extremely precise mixing mechanism creates an aerodynamically identical flow of air and air pressure.
- ◇ Optimum combustion values are always achieved when the forced-air oil burner is properly set.

Functionality

If the thermostat of the warm air generator requests heat for the forced-air oil burner, the oil preheater switches on up to model size 33. The fuel is preheated to the required atomisation temperature and there is a delayed burner start.

At the beginning of the start phase, the burner motor with blower and pump switches on. The fan transports air through the burner and combustion chamber for the pre-ventilation phase.

After the pre-ventilation phase, the magnetic valve opens the fuel supply to the nozzle. An amount of oxygen adjusted to the heating capacity is added to the atomised, high-pressure fuel by the mixing mechanism and shaken.

The oil and air mixture is ignited by arcs at the tips of the ignition electrode. The current required for this is generated by an ignition transformer.

Ignition is ended automatically once a proper flame is burning and the control relay (burner mechanism) has started monitoring the flame.

All functions of the forced-air oil burner are fully automatic and monitored for safety by the control relay. An integrated microprocessor controls the program flow. The individual phases of the program flow are continuously displayed as a blinking code via an information system on an LED integrated into the reset button .

If the flame burns irregularly, becomes unstable or goes out, the control relay switches the forced-air oil burner off by means of a flame regulator.

If there is a malfunction, the LED lights up for 10 seconds and then displays a blinking code that provides information about the cause of the malfunction. This process is continuously repeated. See page 14.

The unit may only be restarted after the control relay has been manually released.

Assembling the Oil Burner

Assembling the burner flange and the burner

1. Place the flange seal 1 on the burner flange.
2. Attach the burner flange to the unit housing with the four screws.
Pay attention to labels "OBEN" (UP, HAUT)!
3. Tighten the two upper screws 2.

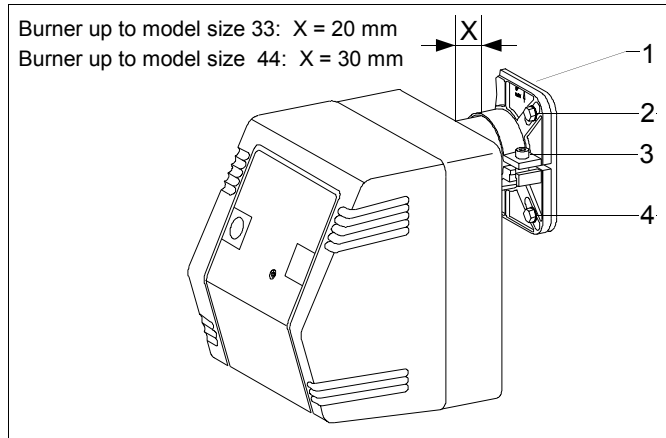

4. Tighten the lower screws 4 but not all the way so that the burner flange can still be pulled together.
5. Slide the flame pipe of the burner into the burner flange.
Observe dimension X in the diagram.
6. Clamp the flame pipe to the flange when the burner is slightly lifted (3° incline).
Use an Allen key.
7. Finally, tighten the lower screws.

Electrical connection

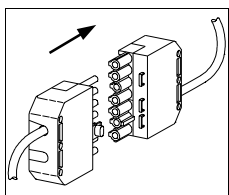

A standard 7-pin plug is usually used for the electrical connection to the warm air generator whose socket is attached to the burner.

Forced-air burners with a heating capacity of more than 350 kW are connected to the 400 V power supply by a separate line.

⚠ The relevant installation instructions and the wiring diagram of the burner must be followed!

Oil connection

The supplied oil hoses are connected to the oil pump and attached with the clamp.

The shut-off and filter mechanisms of warm air generators must be arranged in such a way that hoses can be properly laid. The hoses may not be bent.

Flexible fuel lines in particular must be protected from damage, for example, by forklifts, animals, etc.

Initial Operation

Getting ready

After loosening the 4 housing screws, the assembly base plate is removed from the housing and suspended to the side.

For model sizes SL 44 – SL 66/2, 6 housing screws must be removed (pay attention to the arrow).

The most important functional components for assembly and maintenance are immediately accessible in accordance with the corresponding requirements.

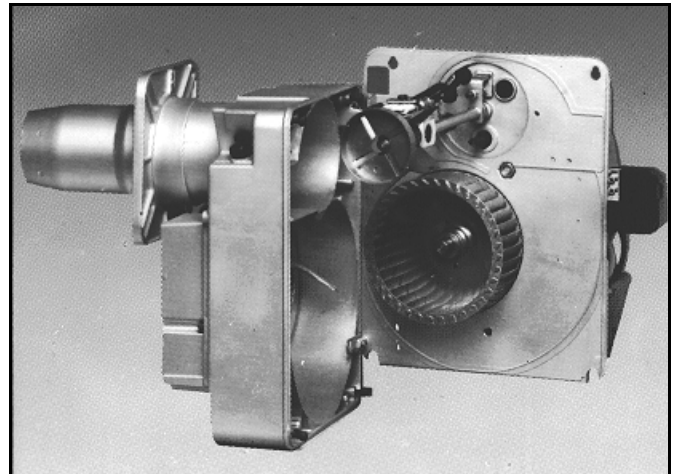

The assembly base plate can also be suspended horizontally for maintenance, installation and replacement of the nozzle.

Proceed as follows:

1. Hold the assembly base plate horizontally.
2. Slide the right mount sideways into the suspension.
3. Suspend the left side up into the lug.

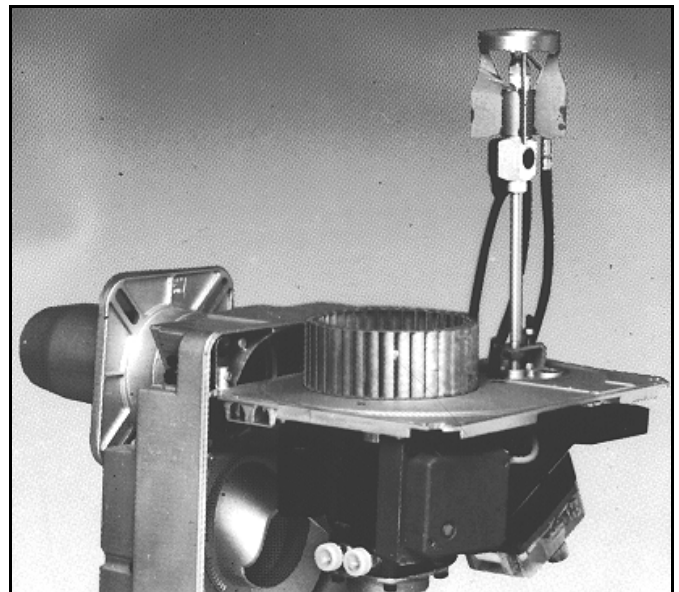

⚠ The forced-air oil burner made only be put into operation by authorised personnel!

Adjusting the ignition electrode and swivel disc

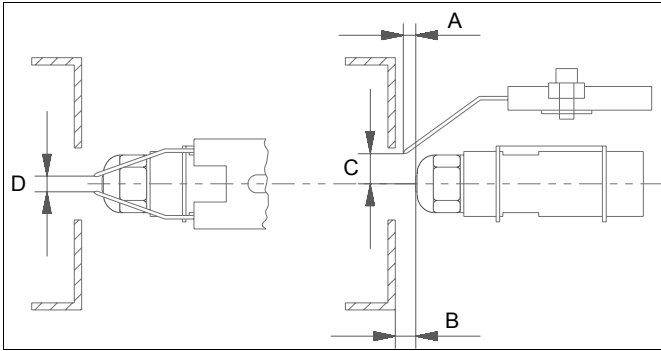

Model size \ dimension	A	B	C	D
SLV 11 - 33	2-4	4-6	7	2.5
SL 44 - SL 66/2	13-15	12-14	5	3
SL 88/2	13-15	14-16	10	4

All dimensions are approximate values in mm. The optimum setting must be adjusted to the local and structural conditions.

Determining the nozzle size

The nozzle size required depends on the pump pressure and the unit capacity (see the type plate of the corresponding warm air generator).

Only a nozzle suitable for the respective combustion chamber geometry with a suitable spray angle, cone-like characteristics and throughput may be used.

Up to burner size 66, oil burner nozzles with a spray angle of 60° must be used for all REMKO units, starting at burner size 88, a spray angle of 80°.

Air intake nozzle

The necessary burner pressure can be adjusted without changing the outlet diameter using the adjustable air intake nozzle depending on the combustion chamber resistance and chimney draft.

- Loosen the Allen screw.
- Rotate the air intake nozzle to the desired position (pay attention to arrow!).

“min” = lower burner pressure
 “max” = higher burner pressure



Assembly base plate

After the nozzle has been changed and the air intake nozzle adjusted, the assembly base plate is reinserted in the reverse order.

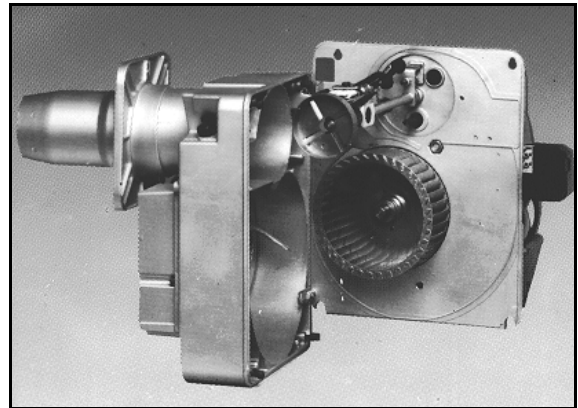

Adjusting the secondary air Nozzle connection rod setting

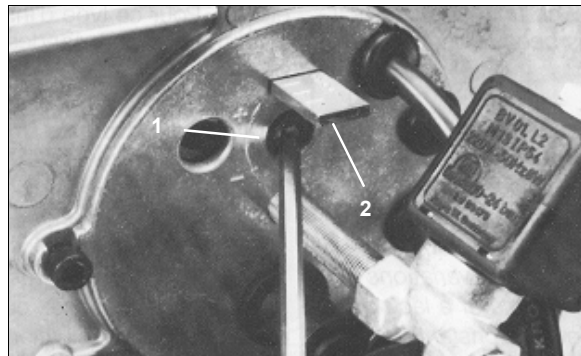

Proceed as follows to preset the secondary air:

Using the adjustment screw 1, set the nozzle connection rod 2 to the desired setting.

SLV 11 and SLV 33

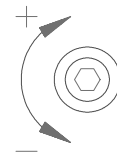

Left rotation (-) = lower scale value

higher pressure behind the swivel disc
lower performance range

Right rotation (+) = higher scale value

lower pressure behind the swivel disc
upper performance range

SL 44 and SL 88/2

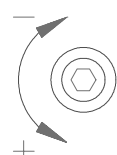

Left rotation (+) = higher scale value

lower pressure behind the swivel disc
upper performance range

Right rotation (-) = lower scale value

higher pressure behind the swivel disc
lower performance range

Air flap up to model size SL 44

The amount of air required is set using the adjustment screw **3**. When the upper edge of the screw **3** is set to "0", this is the "min" setting.

The air flap is opened or closed until the soot pattern displays an oil-free colour "0 - 1".

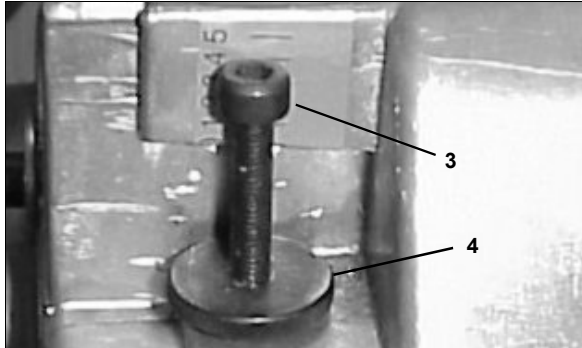

Adjusting the air flap up to model size SL 44

Proceed as follows to adjust the air flap:

1. Loosen the knurled nut **4**.
2. Rotate the adjustment screw **3** accordingly.
3. Keep in mind that generally the following mean:
Right rotation = less air
Left rotation = more air
4. After the adjustment is made, retighten the adjustment screw with the knurled nut.

Additional information

- ◇ If, when the air flap is completely open, the flame emits soot or does not burn evenly, the pressure behind the swivel disc must be reduced with the secondary air setting.
- ◇ It is also possible that it is necessary to open the air intake nozzle more.

 **For burners starting at model size SL 55/2, the air flap is set using an adjustment motor.**
See special instructions for adjusting the air flap!

Adjusting the pump pressure

The oil pressure must be adjusted and/or checked prior to operation and maintenance.

Do not run the pump without oil!

Adjust the pump pressure as follows.

1. Remove the plug on the "P" measuring connection.
2. Mount the oil manometer
3. Open all oil shut-off mechanisms.
4. Switch the burner on.
5. Adjust the necessary oil pressure in accordance with the nozzle size and the unit capacity.
6. Switch the burner off.
7. Disassemble the oil manometer.
8. Replace the plugs with seal again properly.

Measuring combustion gases

Every stationery furnace must be checked in accordance with the 1st German Emissions Act by measuring the exhaust values.

Four weeks after initial operation of the furnace, the operator is required to have measurements performed by the district chimney sweep. In addition, §§ 9 and 15 of the Emissions Act require that the immissions (oil derivatives, soot, exhaust gas loss) be checked once a year by the district chimney sweep.

The exhaust loss is calculated using the following formula:

$$q_A = (t_A - t_L) \times \left(\frac{A_1}{CO_2} + B \right)$$

q_A = exhaust loss in %

t_A = exhaust temperature in °C

t_L = combustion air temperature in °C

CO_2 = volume concentration of carbon dioxide in dry exhaust

A_1 = 0.5 (fuel-specific constant)

B = 0.007 (fuel-specific constant)

Decimal values up to 0.5 are rounded down, values above 0.5 are rounded up.

Important information

All REMKO standard heaters must always be operated with nominal load.

All two-level burner models may only be operated at the second level. The first burner to level may only be used as **start-up relief!**

To ensure the optimum function of the burner, it should be serviced once a year in accordance with DIN 4755. We recommend concluding a **service agreement** for this purpose

If operational cleaning and burner adjustment intervals are not observed, the guarantee becomes null and void. It is therefore absolutely necessary to document that the work was performed by authorised personnel. A measurement log for this purpose must be created.

 **An operation/use other than indicated in these instructions is prohibited!**

In the case of non-compliance, we assume no liability and our guarantee becomes null and void.

For the guarantee to be valid, the customer must completely fill out the "**guarantee certificate**" enclosed with all heating units and send it back to REMKO GmbH & Co. KG in a timely manner after purchasing of the unit and putting it into operation.

Adjusting the Air Flap (SL 55/2 and SL 66/2)

Setting the Conectron LKS 130-2 adjustment motor

The adjustment motor has the activation function “Air quantity level 1” and an activation contact for the “Magnetic valve level 2”.

The adjustment motor remains in this position when the control is switched off in the “Air quantity level 2” position and, when restarted, returns to the “Air quantity level 1” position.

When assembling the burner, the opening scale was fixed in such a way that the position 0° corresponds to a closed air flap. When the burner is shipped, an opening angle of 30° “Air quantity level 1” is preset for the air flap.

The preset opening angle for the “Air quantity level 2” is 50°.

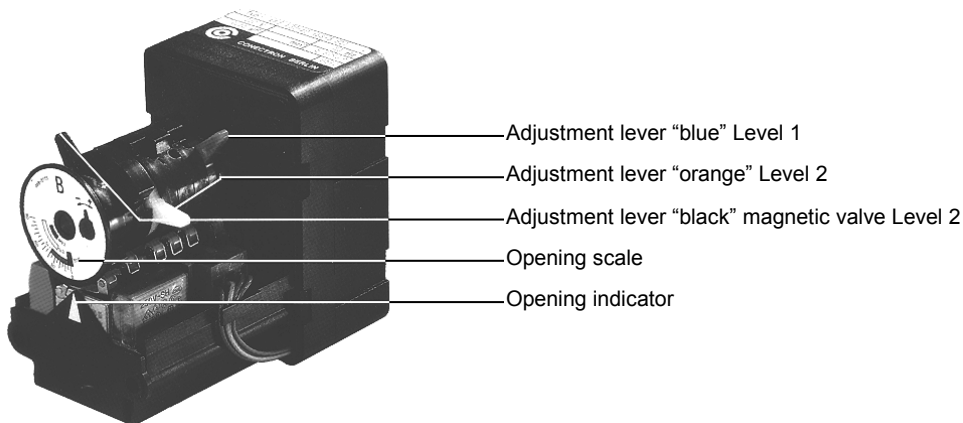

Setting “Air quantity level 1”

Adjustment lever **blue**

1. Unplug the 4-pin multi-purpose connection. *Thermostat level 2.*
2. Turn the orange adjustment lever “Air quantity Level 2” and the black adjustment lever “Magnetic valve 2” clockwise until both **activation cams** are initially not pressed down so that the setting the activation cam for the “Air quantity 1” is not blocked.

Less air Level 1:

Set the blue adjustment lever counter-clockwise to the smaller opening angle. When the burner is running, the adjustment motor automatically adjusts.

More air Level 1:

Set the blue adjustment lever clockwise to the larger opening angle. When the burner is running, the adjustment motor automatically adjusts.

Activation point “Magnetic valve 2”

Adjustment lever **black**

The adjustment lever for “Magnetic valve 2” is now rotated back counter-clockwise and the activation point “Air quantity 2” is placed briefly behind the “Air quantity 1” activation point. This activation point works between the positions “Air quantity Level 1” and “Air quantity Level 2”.

Important information

Please make sure that the activation cam from “Magnetic valve 2” is not pressed before activation cam “Air quantity level 1” because otherwise the “Magnetic valve 2” in the “Air quantity 1” area opens and the burner would run with an insufficient quantity of air.

Setting “Air quantity level 2”

Adjustment lever **orange**

1. Turn back the adjustment lever for the “Air quantity level 2” counter-clockwise.
2. Determine the activation point for the “Air quantity level 2” based on the burner capacity behind the activation point “Magnetic valve 2”.
3. Plug in the 4-pin multi-purpose connection of Thermostat level 2 again.

The adjustment motor runs via “Magnetic valve 2” to the position “Air quantity level 2”.

Less air Level 2:

Set the orange adjustment lever counter-clockwise to the smaller opening angle. Switch to the burner briefly back to Level 1. After the unit is switched back to Level 2, the adjustment motor’s speed adjusts to the changed quantity of air.

More air Level 2:

Set the orange adjustment lever clockwise to the larger opening angle. When operating at Level 2, the speed of the adjustment motor adjusts automatically.

 **Make sure that there are no mechanical defects on the adjustment motor or the air flap otherwise the adjustment motor will be damaged.**

Adjusting the Air Flap (SL 88/2)

Setting the Conectron LKS 160 adjustment motor

The adjustment motor has the following activation functions:

“Position 0”, “Level 1” and “Level 2” as well as an activation contact for the Magnetic valve level 2. The adjustment motor is also equipped with a reset lever.

When burner is assembled, the opening scale was fixed in such a way that the position 0° corresponds to a closed air flap.

When the flap is completely open, this corresponds to an angle of approx. 90°. For a control deactivation, the adjustment motor is reset to the 0 factory setting.

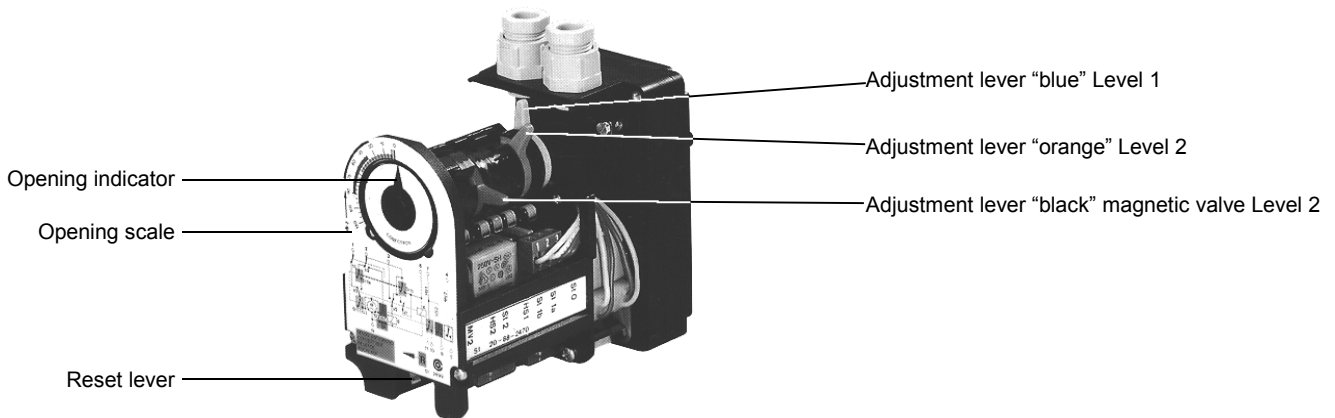

Adjusting the air flap

The air flap is opened or closed until the soot pattern displays an oil-free colour, soot “0 - 1” and value 12-14 % for the CO₂.

When making the adjustment, keep in mind that when there is a lot of excess air, the soot increases again and oil can appear again in the soot pattern. If, when the air flap is completely open, the flame emits soot or does not burn evenly, the pressure behind the swivel disc must be reduced with the adjustment screw.

Setting “Air quantity level 1”

*Adjustment lever **blue***

Less air Level 1:

Set the blue adjustment lever to a smaller value by turning it counter-clockwise. When the burner is running, the adjustment motor **automatically** adjusts.

More air Level 1:

Set the blue adjustment lever to a smaller value by turning it clockwise. When the burner is running, the adjustment motor **automatically** adjusts.

Setting “Air quantity level 2”

*Adjustment lever **orange***

Less air Level 2:

Set the orange adjustment lever to a smaller value by turning it counter-clockwise. Keep in mind that the adjustment motor **does not adjust its speed automatically**. Press the reset lever briefly, the adjustment motor then adjusts to the set value.

More air Level 2:

Set the orange adjustment lever to a larger value by turning it clockwise. When the burner is running, the adjustment motor **automatically** adjusts

Activation point “Magnetic valve 2”

*Adjustment lever **black***

The activation point for magnetic valve 2 must lie between the activation point of the orange activation lever and the blue one.

Important information

Please make sure that the cam of the black adjustment lever is **never** pressed to Level 1.

At Level 2, the cam of the black adjustment lever must be pressed, otherwise the fuel quantity for Level 2 is not released.

 **Make sure that there are no mechanical defects on the adjustment motor or the air flap otherwise the adjustment motor will be damaged.**

Functional result of the adjustment motor

1. During the pre-ventilation phase, the adjustment motor accelerates to the activation point of the 2nd level.
SL 77/2 – 88/2.
2. Shortly before opening MV 1, the adjustment motor returns to Air quantity level 1 and the burner begins operation.
3. After the through-connection of thermostat 2, the adjustment motor adjusts its speed to Air quantity level 2 and opens briefly after exiting the 1st level MV 2.
4. Thermostat level 2 switches the burner off and the adjustment motor returns to Level 1.
The burner remains at Level 1 during operation.
5. Thermostat level 2 switches burner operation off and the adjustment motor turns to Position 0.

Wiring Diagram

Control relay DKW 976 for the model sizes SLV 11 to SL 44

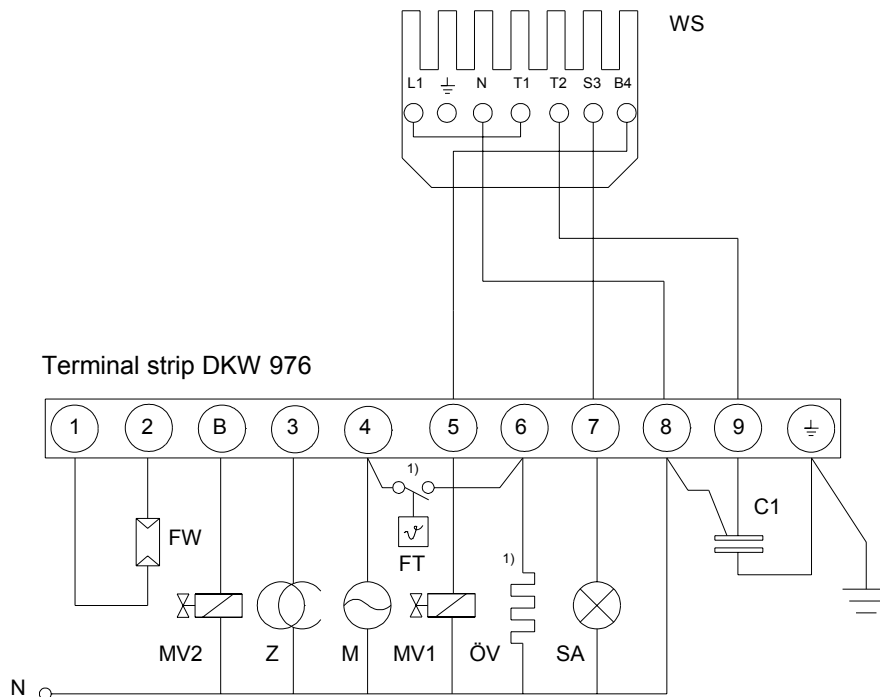

1) **Note:** Burner of the SL 44 model size without nozzle connection rod preheater. Preinstalled bridge from terminal 4 to 6.

Control relay DKW 972 model sizes SL 55/2 and SL 66/2

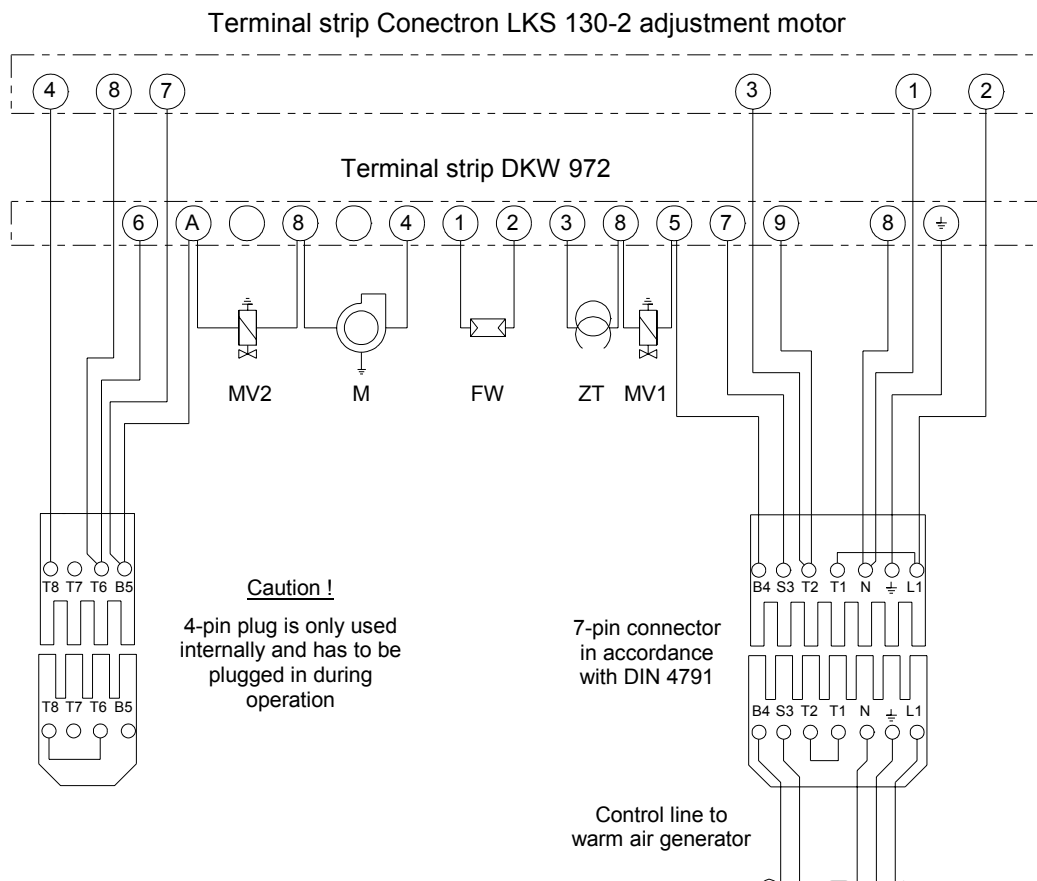

We reserve the right to make changes to dimensions and design in the interest of technical progress.

Control relay TMO 720-4 only model size SL 88/2

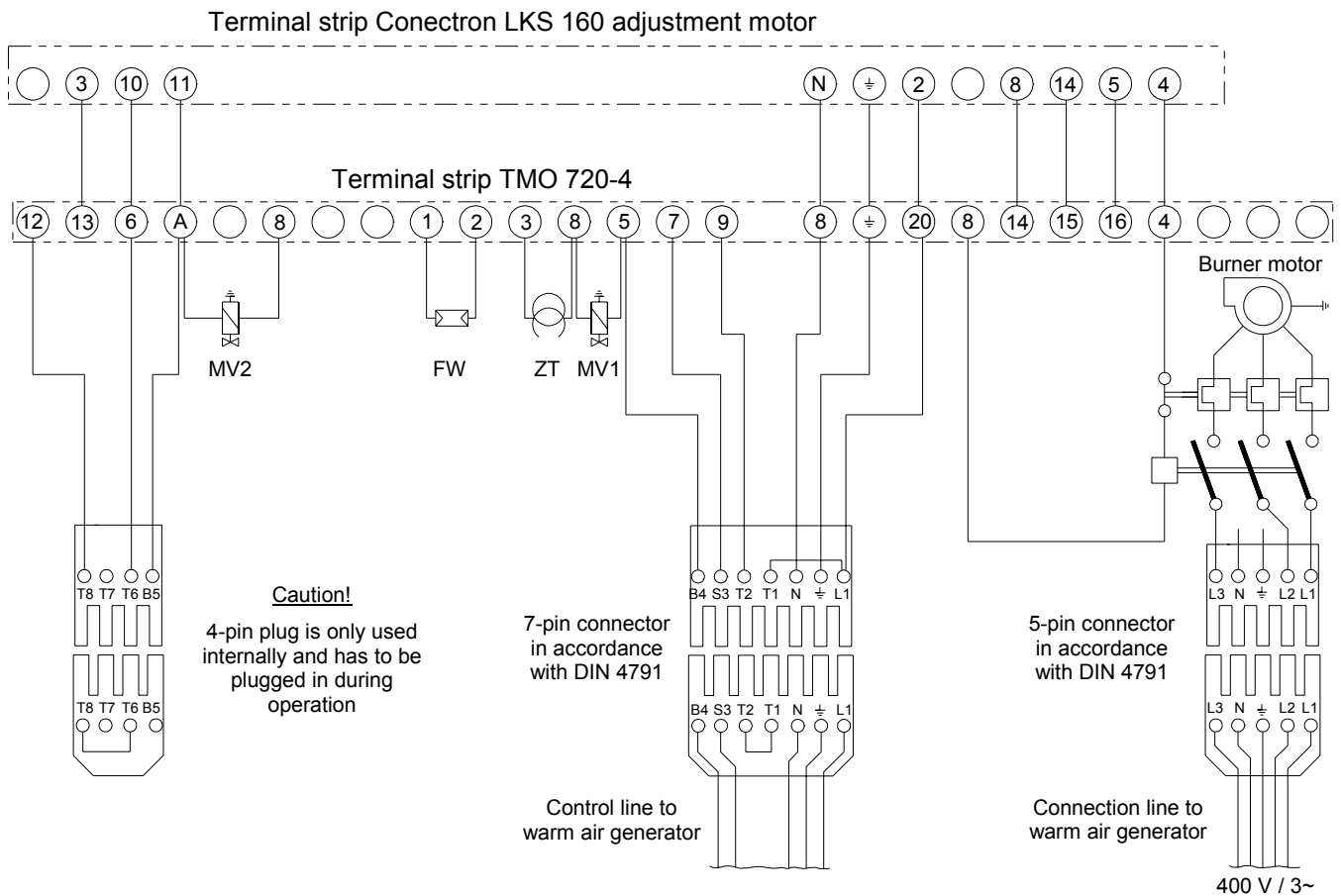

Wiring diagram key

- C1 = Reset condenser
- FT = Release thermostat
Nozzle connection rod preheater
- FW = Photo resistance
- M = Burner motor
- MV1 = Magnetic valve 1st level
- MV2 = Magnetic valve 2nd level
- ÖV = Nozzle connection rod preheater
- SA = External malfunction display
- WS = 7-pin plug to warm air generator
- Z = Ignition transformer

Important information.

- All REMKO standard heaters must always be operated with nominal load.
- All two-level burner models may only be operated in the second burner level.
- The first burner level may only be used as start-up relief!

We reserve the right to make changes to dimensions and design in the interest of technical progress.

Exploded View

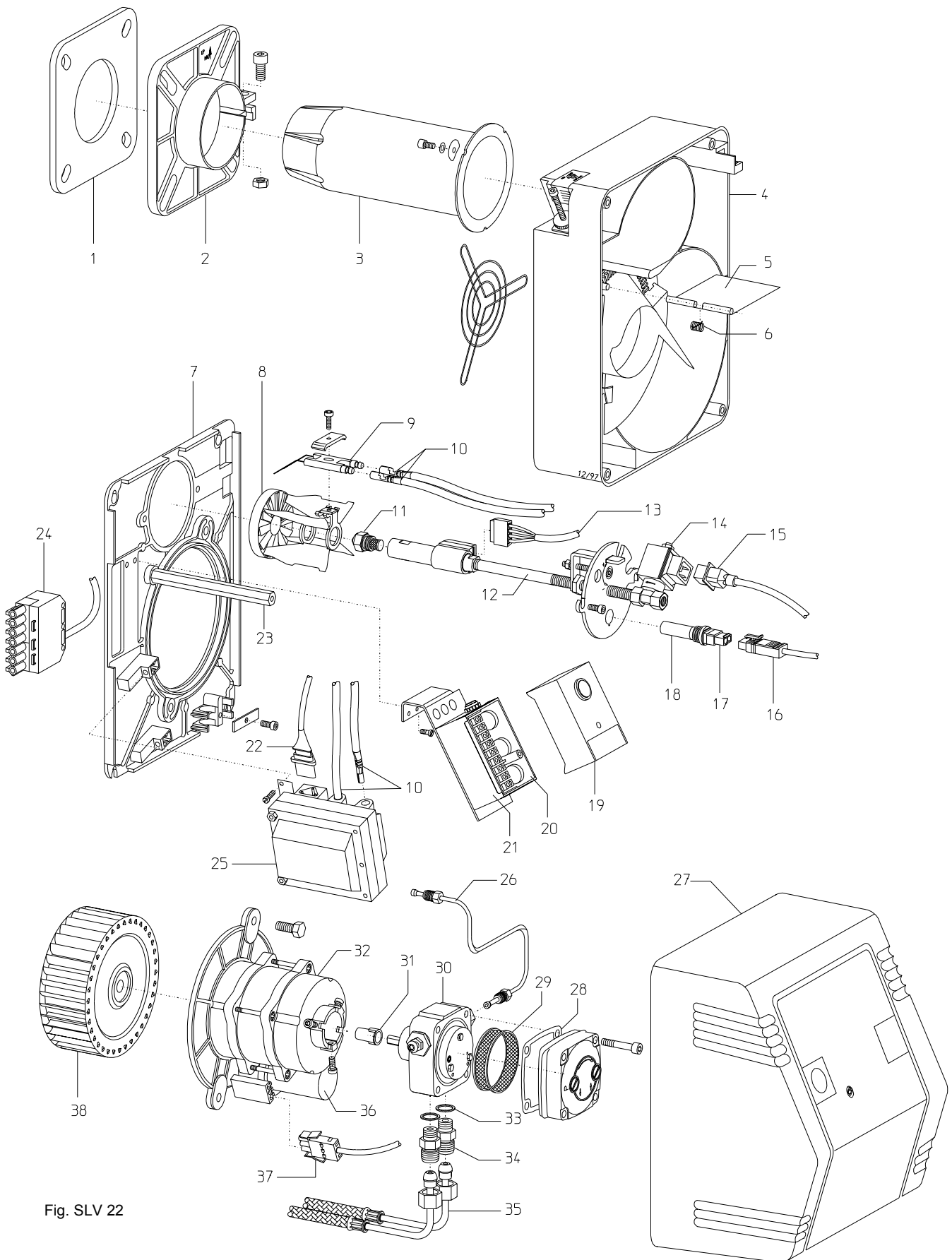

Fig. SLV 22

We reserve the right to make changes to dimensions and design in the interest of technical progress.

Spare Parts List

No. Name	SLV 11	SLV 22	SLV 33	SL 44	SL 55/2	SL 66/2	SL 88/2
	Ref. No.	Ref. No.	Ref. No.	Ref. No.	Ref. No.	Ref. No.	Ref. No.
1 Flange seal	1108540	1108540	1108535	1108538	1108538	1108538	1108560
2 Burner flange	1108518	1108518	1108536	1108539	1108539	1108539	1108559
3 Flame pipe	1108533	1108533	1108534	1108529	1108517	1108541	1108545
4 Burner housing	1108507	1108507	1108507	1108508	1108508	1108508	-----
5 Air flap	1108580	1108580	1108580	1108581	1108581	1108581	1108582
6 Air flap spring	1105076	1105076	1105076	1105076	1105076	1105076	-----
7 Assembly base plate	1108575	1108575	1108575	1108576	1108576	1108576	-----
8 Turbolator (swivel disc)	1108530	1108531	1108532	1108528	1108528	1108528	1108548
9 Ignition electrode	1108524	1108524	1108524	1108570	1108570	1108570	1108558
10 Ignition cable (set)	1108574	1108574	1108574	1108574	1108574	1108574	1108584
11 Oil nozzle	When ordering, please provide unit type/model size and nozzle spec.						
12 Nozzle connection rod, pl.	1108525	1108525	1108525	1108588	1108588	1108588	1108589
13 Cable for nozzle connect. rod incl. preheater	1108579	1108579	1108579	-----	-----	-----	-----
14 Magnetic valve	1102111	1102111	1102111	1102111	1102111	1102111	1102113
15 Cable incl. plug for magnetic valve	1102825	1102825	1102825	1102825	1102825	1102825	1102825
16 Cable incl. plug for photoelectric cell	1108207	1108207	1108207	1108207	1108207	1108207	1108207
17 Photoelectric cell	1108206	1108206	1108206	1108206	1108206	1108206	1102540
18 Photo cell cover	1108583	1108583	1108583	1108583	1108583	1108583	-----
19 Control relay	1108191	1108191	1108191	1108191	1108192	1108192	1108551
20 PG plate	1102533	1102533	1102533	1102533	1102533	1102533	1102533
21 Relay socket	1108190	1108190	1108190	1108190	1108190	1108190	1108555
22 Cable incl. plug for ignition transformer	1108573	1108573	1108573	1108573	1108573	1108573	-----
23 Cover bolt	1108590	1108590	1108590	1108590	1108590	1108590	1108591
24 Tip jack, 7 lines	1102536	1102536	1102536	1102536	1102536	1102536	1102536
25 Ignition transformer	1108523	1108523	1108523	1108523	1108523	1108523	1108557
26 Pressure pipe	1108521	1108521	1108521	1108549	1108549	1108549	1108564
27 Burner protection cover	1108500	1108500	1108500	1108501	1108501	1108501	1108546
28 Cover seal	1108454	1108454	1108454	1108454	1108598	1108598	1108598
29 Oil pump filter	1108409	1108409	1108409	1108409	1108599	1108599	1108599
30 Oil pump, cpl.	1108499	1108499	1108499	1108595	1108596	1108596	1108597
31 Pump coupling	1108520	1108520	1108520	1108520	1108520	1108520	1108562
32 Burner motor	1108505	1108505	1108505	1108506	1108506	1108506	1108556
33 Sealing ring 1/4", 13x18x1,5	1108577	1108577	1108577	1108577	1108577	1108577	1108577
34 Connection hose nipple	1108568	1108568	1108568	1108568	1108568	1108568	1108568
35 Oil hose	1108537	1108537	1108537	1108587	1108587	1108587	1108567
36 Condenser for burner motor	1108592	1108592	1108592	1108593	1108593	1108593	-----
37 Cable incl. plug for burner motor	1108571	1108571	1108571	1108571	1108571	1108571	-----
38 Fan wheel	1108510	1108510	1108510	1108511	1108511	1108511	1108553
Not pictured							
Plug, 7-pin	1102537	1102537	1102537	1102537	1102537	1102537	1102537
Socket, 4-pin	-----	-----	-----	-----	1108565	1108565	1108565
Plug, 4-pin	-----	-----	-----	-----	1108585	1108585	1108585
Adjustment motor	-----	-----	-----	-----	1108542	1108542	1108543

We reserve the right to make changes to dimensions and design in the interest of technical progress.

Troubleshooting

Instructions for the operator

If a problem occurs, the following basic prerequisites for proper operation should first be checked:

- ◇ Is the power connection OK?
- ◇ Is the fuel supply OK?
- ◇ Are all shut-off mechanisms open?
- ◇ Are all control and safety mechanisms functioning properly?

Information about burner malfunctions

If a problem occurs in the burner, the LED in the reset button of the control relay lights up continuously. Every 10 seconds, the display is interrupted by a blinking code (see below) that provides information about the cause of the malfunction.

- ◇ The malfunction is cleared by pressing the clear button **once** (error log).
- ◇ Once the problem has been eliminated, the burner tries to start again.
Remember that the burner start is delayed by the oil preheater up to model size SLV 33!
- ◇ If the burner switches off again due to a malfunction while trying to restart, the unit may only be reset after a waiting 5 minutes.
- ◇ **No further resets may be performed after this because there is a danger of explosion and the forced-air oil burner and warm air generator can be damaged.**
- ◇ In this case, please notify an authorised service centre.

 **Burner repair and maintenance work may only be performed by authorised personnel for safety reasons!**

Instructions for authorised personnel

 **Prior to all work on the forced-air oil burner, all lines must be removed from the power supply!**

The burner motor does not start

- ◇ No current supply.
Check fuses, main switch, thermostat, (clock timer), safety temperature limiter.
- ◇ Oil preheater (up to SLV 33) defective.
- ◇ Burner motor defective.
- ◇ Oil pump defective, *pump cranks with difficulty.*
- ◇ Control relay defective.

No ignition

- ◇ Ignition electrode defective or incorrect distance to the ignition electrodes.
- ◇ Ignition cable or ignition transformer defective.
- ◇ Control relay defective.

The magnetic valve does not open

- ◇ Magnetic valve is defective
- ◇ Photoelectric cell contains external light
- ◇ Cable with plug to the magnetic valve does not have any contact
- ◇ Control relay defective

A flame does not form

- ◇ Not enough fuel supply
- ◇ Wax buildup in the fuel system
- ◇ Dirty oil filter
- ◇ Air in the fuel system
- ◇ Oil pump or pump coupling defective
- ◇ Dirty pump filter
- ◇ Dirty oil nozzle

Flame does not continue to burn after the safety period has elapsed

- ◇ Photoelectric cell is dirty or defective
- ◇ Swivel disc is sooty
- ◇ Photo cell is not receiving a flame signal
- ◇ Burner burns with an insufficient amount of air (flame is too dark)
- ◇ Control relay defective

Flame does not keep burning after the ignition time has elapsed

- ◇ Flame goes out or does not burn evenly.
Pump pressure too low, possible that there are air bubbles in the fuel system.

Control relay DKW 972/976 with LED display

Sequence flow

These repeat until the problem is eliminated

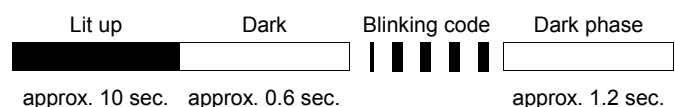

Description of the signals

| = short pulse ■ = long pulse _ = pause

Blinking codes to diagnose problems

Error message	Blinking code	Cause of problem
Malfunction deactivation	■ ■ ■ ■ ■	No flame detected within the safety period
External light disturbance	■ ■ ■ ■	External light during the monitored phase, sensors possibly defective
Release thermostat time-out	■ ■ ■	FT contact does not close within 400 sec.
Manual / external malfunction deactivation	■ ■ ■ ■ _ ■ ■ ■ ■ ■	

Measurement and Service Log

Model size / device type (warm air generator)	/										
Burner number / device number (warm air generator)	/										
CO ₂ content on the exhaust pipe adapter											%
CO content on the exhaust pipe adapter											%
Amount of soot according to Bacharach											
Exhaust gas temperature											°C
Heating room temperature											°C
Exhaust temperature minus room temperature											°C
Chimney draft on the exhaust pipe adapter											mbar
Excess pressure in the furnace room											mbar
Exhaust losses											%
Furnace efficiency degree											%
Burner cleaned											
Impermeability of oil-conducting lines checked											
Safety mechanisms checked											
Protective mechanisms checked											
Nozzle replaced											
Filter checked/replaced											
Comments:											
.....											

1st Date:.....	2nd Date:	3rd Date:	4th Date:.....	5th Date:.....
..... Signature Signature Signature Signature Signature
6th Date:	7th Date:	8th Date:	9th Date:.....	10th Date:.....
..... Signature Signature Signature Signature Signature

Service Instructions

Only have the forced-air oil burner serviced by trained and authorised personnel in accordance with the legal requirements. It is not permitted to service components with safety functions. They may only be replaced with original parts.

To ensure the optimum function of the burner, dirt and dust must be cleaned from the entire burner after every heating period or earlier depending on the operating conditions.

Parts subject to wear and tear such as oil filters (on the unit side) and oil nozzles must be checked and replaced if necessary.

Each time the unit is serviced, the exhaust must be measured in accordance with § 14 of the German Emissions Law.

Maintenance steps:

- ◇ Clean any combustion residue sticking to the swivel disc.
- ◇ Check the distance of the ignition electrodes.
Reposition if necessary or replace the ignition electrode.
- ◇ Clean the filters of the pump and magnetic valve.
- ◇ Replace the oil nozzle when necessary.
- ◇ Clean the nozzle connection rod and the oil line.
- ◇ Clean any dust or dirt particles sticking to the fan wheel if necessary.
- ◇ Check the pump pressure and adjust if necessary.

REMKO GmbH & Co. KG

Klima- und Wärmetechnik

D-32791 Lage · Im Seelenkamp 12

D-32777 Lage · PO Box 1827

Phone +49 (5232) 606 - 0

Fax +49 (5232) 606260

E-Mail: info@remko.de

Internet: www.remko.de