



REMKO ATR-4

**Electronic
Clock Thermostat**

Edition GB - H12

Operation Technology

Original REMKO

REMKO - powerful like a bear

Operating Instructions

This electronic clock thermostat is used for room temperature-dependent, two-point control of heating and cooling units in dry and closed rooms.

Read these instructions carefully before setting up/operating the unit!

Our guarantee becomes null and void if the unit is used improperly or if modifications are made to the supplied unit.

Electronic Clock Thermostat REMKO ATR-4

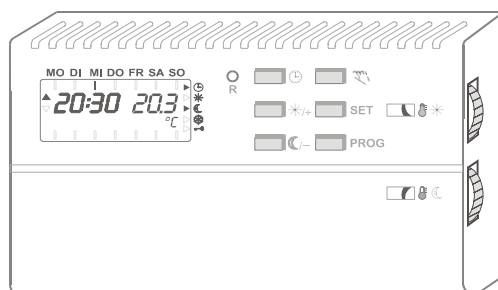

Contents	Page	Contents	Page
Functionality	4	Selecting the Operating Mode	6
Operating Controls	4	Setting the Timer	7
Comfort Temperature	4	Setting the Control Parameters	8
Cooling Temperature	5	Setting the Functions	8+9
Frost Protection Temp.	5	Installation Instructions	10
Hand Button	5	Mounting	11
Off	5	Wiring Diagram	12
Reset	5	Customer Data	13
Setting the Clock	6	Technical Data	14

Important!

Always keep these operating instructions near or on the unit.

Functionality

- The ATR-4 electronic clock thermostat records the room temperature either using an internal NTC temperature sensor or an external KTY temperature sensor.
- The output is activated via an isolated change-over contact.
- The digital weekly clock timer controls temperature in automatic mode (comfort temperature or cooling temperature). It has 16 programs that can be used to program up to 112 activation times. The timer has a power reserve of 15 minutes.
- The mode can be selected using the program buttons (4): Automatic, Heating, Cooling, Frost Protection and Off modes are available.
- An indicator (5) on the left-hand side of the display shows the operating mode.

Operating Controls

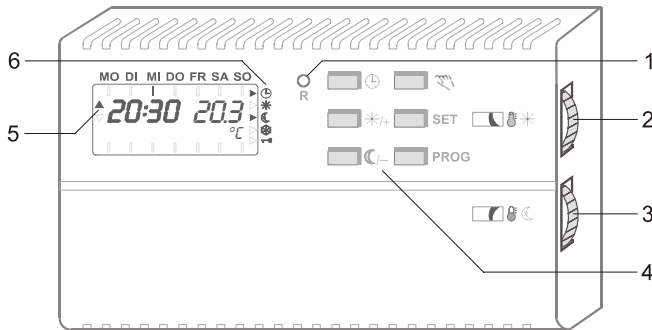

1. Reset button
2. Adjustment wheel (Comfort temp.)
3. Adjustment wheel (Cooling temp.)
4. Program buttons
5. Operating status indicators
6. Operating mode indicators

Comfort Temperature

The desired comfort temperature (5 to 40 °C) is set on the upper rotating knob (2). It is displayed on the right-hand side of the display instead of the current temperature. Three seconds after the knob has been turned, the unit automatically displays the current temperature again.



Note: A change to the comfort temperature makes it necessary to change the cooling temperature by the same amount because the cooling temperature is relative to the comfort temperature. Conversely, a change in the cooling temperature does not require a change in the cover temperature.

Cooling Temperature

The cooling temperature can be set on the lower adjustment knob (3). It is displayed absolutely on the right half of the display. Three seconds after the knob is turned, the unit automatically displays the current temperature again.



Note: To protect against frost, the cooling temperature may not be set below + 5 °C.

The current target value can be queried by pressing the **SET** program button. After three seconds, the current temperature is displayed again.

Frost Protection Temperature

The frost protection temperature is fixed at 5 °C. By pressing the two program buttons + and –, the frost protection temperature can be selected.

The frost protection level is not accessible via the timer program or in cooling mode.

Hand Button

The  button makes it possible to change the current temperature mode (comfort temperature / cooling temperature) in automatic mode. The selected temperature mode is displayed by indicators on the right-hand side of the display. This function is deleted for the next program point.

Off

By pressing the two program buttons  and + at the same time, the operating mode is no longer displayed on the right-hand side of the display. The unit continues to record the current temperature but all control functions are completely switched off.

Reset

There are two different reset options:

1. Start up reset:

The **RESET** button (3) makes possible to restart the unit after operation has been interrupted due to a malfunction. The clock must be reset but the program and parameter settings are retained.

2. Global reset

To force the unit to restart with the factory settings, the buttons **RESET**, + and – must be pressed at the same time. After the **RESET** button is released, the buttons + and – must be held down until the version number (r 10...) appears on the display.



Note: Any previously entered individual timer program and any parameter settings are lost.

Setting the Clock

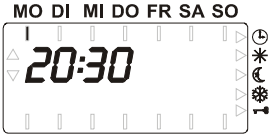

The clock can be set once the  program button has been held down for 3 seconds or after the unit restarts following a reset. If the clock has not yet been reset, it blinks on the display.

When you press the **SET** program button, you are taken to the desired setting option (*Hours -> Minutes -> Day of the week*). The selected option blinks on the display.

By pressing one of the program buttons **+** or **-**, the value of the selected option can be changed and the selection confirmed by pressing the **SET** button.



After confirming the day of the week, the clock starts accurate to the second. The unit returns to the operating mode from which the “**Set Clock**” menu was accessed. If no button is pressed within 1 minute, the current time automatically appears again.



Programming Example: Monday, set 10:16

Display	Button	Explanation
1.		Change time setting
2. 20:30	+/-	Hours blinking; change setting with [-]
3. 10:00	SET	Confirm entry
4. 10:00	+/-	Minutes blinking; change setting with [+]
5. 10:16	SET	Confirm entry
6. *	+/-	Day blinking; change setting with [+/-]
7. *	SET	Confirm entry and end programming

Selecting the Operating Mode



The main operating modes are selected by pressing one of the three program buttons on the left. You can select from the following modes: *Automatic* , *Comfort* * (continuous) and *Cooling*  (continuous).

The *Off*  and *Frost protection*  modes can be set by pressing the top and middle or bottom and middle program buttons on the left at the same time.

The selected operating mode is displayed by indicators on the right-hand side of the display. In the *Automatic* operating mode, one of the two indicators also shows the currently valid temperature control (Comfort or Cooling). No indicator is displayed in the **Off** operating mode.

Setting the Control Parameters

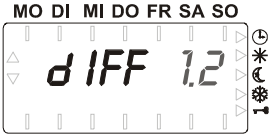

When you press the **PROG** program button for 6 seconds, you are taken to a menu where various basic functions can be set. The functions are shown on the left-hand side of the display and the corresponding value or status on the right.

When you press the **SET** program button, you are taken to the desired setting option. The setting option blinks on the display.

By pressing the **+** or **-** program buttons, the value of the selected setting options can be changed and your selection confirmed by pressing the **SET** button.

After confirming the last function, the unit returns to the operating mode from which the “**Setting the Control Parameters**” menu was accessed.

The individual parameters mean the following:

When used as a two-point control mechanism:

Parameter	Default setting	Minimum value	Maximum value
Activation difference	$\pm 1.0 \text{ K}$	$\pm 0.1 \text{ K}$	$\pm 3.0 \text{ K}$

When used as a pulsating control mechanism:

Per proportional control	$\pm 3.0\text{K}$	$\pm 1.0 \text{ K}$	$\pm 10.0 \text{ K}$
Pulse width	5 min	1 min	15 min

Setting the Functions



When you press the **PROG** program button for 6 seconds, you are taken to a menu where various basic functions can be set. The functions are shown on the left-hand side of the display and the corresponding value or status on the right.

When you press the **SET** program button, you are taken to the desired setting option. The setting option blinks on the display.

By pressing the **+** or **-** program buttons, the value of the selected setting options can be changed and your selection confirmed by pressing the **SET** button.

After confirming the last function, the unit returns to the operating mode from which the “**Setting the Functions**” menu was accessed.

The individual parameters mean the following:

Preset: Limits: **SEnS** (Sensor comparison display)
0.0 K $\pm 3.0K$ Constant temperature values should be available for the sensor comparison. In addition, the sensor comparison should be performed at normal room temperatures (approx. 20 °C). For a comparison, the current temperature displayed by the unit and the temperature on the sensor must be known. The difference between these two values can be set within a $\pm 3.0K$ limit under the **SEnS** menu item.
Example: The unit displays 20.7 °C. The temperature measuring unit displays a temperature of 19.9 °C on the sensor. – **0.8** must be set under the **SEnS** menu item.

Preset: Alternative: **H C** (Heating / Cooling display)
HE **Co**
(heating) (cooling) In **Heating** mode, the controlled relay on the left-hand side of the display shows an arrow pointing up (Δ). In **Cooling** mode, it displays an arrow pointing down (∇).

Preset: Alternative: **2PPu** (2-point / Pulsating function display)
2-P **PuL**
(2-point) (pulsating) When the control function is switched from 2-point to pulse and vice versa, this results in the corresponding parameters being calculated on the basis of the default settings. These settings are explained under “**Setting the Control Parameters**”. If necessary, the values must be changed as described in this section.

Preset: Alternative: **IE** (internal / external sensor)
I **E**
(internal) (external) If the external sensor is selected but there is not KTY temperature sensor connected, 65.0 °C appears on the display. The clock thermostat is not controlling the output.

Preset: Alternative: **Loc** (button lock)
oFF **on**
(inactive) (active) The button lock is displayed by the key symbol. The button lock prevents the temperatures from being changed using the rotating knobs. After the button lock has been released, any temperature changes are transferred. The button lock is activated by pressing the **PROG** program button for 6 seconds.

Installation Instructions



Warning: The unit can be damaged if it is connected improperly! We are not liable for damages that are the result of incorrect connection and/or improper use!

For the authorised electrical installation personnel!

- Connection and service may only be performed by authorised electrical personnel!
- Prior to performing any work on the unit, all power lines must be free of electrical current and secured against switching on again!
- Connection is to be performed in accordance with the wiring diagram on page 12.
- The unit may only be connected to lines that are permanently attached in closed, dry rooms.
- When installing the unit, make sure that the electrical lines, for example, power supply and relay connection lines, cannot come into contact with low-current supply lines, such as sensor lines (minimum distance 4 mm for basic isolated line conductors).
- Make sure that there is adequate protection to prevent connection conductors from becoming loose that meets the requirements of EN 60730 Part 1. This can be achieved, for example, by securing the lines with cable bindings.
- Compliance with VDE 0100, EN 60730, Part 1, as well as all regulations of the local EVU must be assured.
- If the unit does not function as expected, first check the power supply and that the unit has been properly connected.
- To prevent problems, the external sensor lines may not be laid together with the other power conducting lines. A minimum distance of 4 mm must be maintained for basic isolated conductors.
- Use the sensor lines in accordance with the requirements. Observe the maximum line length and required minimum cross-sections!

Max. line length	Line cross-section (Cu)
30 m	0.50 mm ²
45 m	0.75 mm ²
60 m	1.00 mm ²
90 m	1.50 mm ²

Mounting

The clock thermostat is suitable for mounting on many European lower wall sockets as well as for conventional wall-mounting with wall cable slot.

When mounting on the wall, make sure that only the part intended for the cable slot is separated from the bottom of the housing.

If the entire panel is removed, it is possible that the housing no longer completely closes.

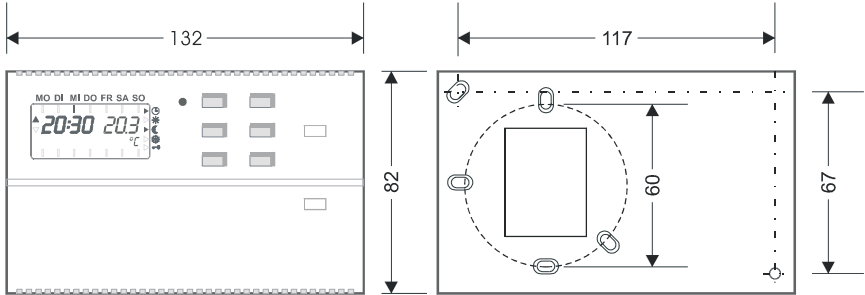

Note: The electronic clock thermostat should be attached to inner walls approx. 1.5 m above the floor.

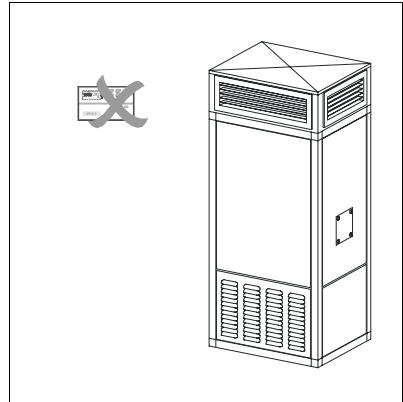
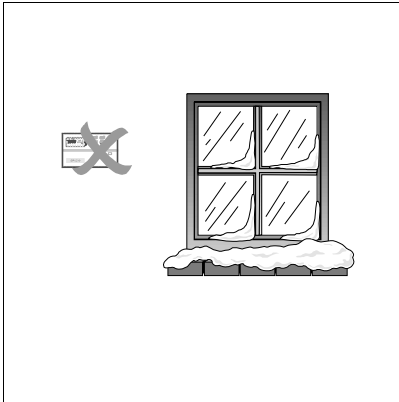

Note: The electronic clock thermostat must be mounted on the wall in such a way that it can measure the average room temperature. Drafts and proximity to windows and doors or sources of heat, etc. are to be avoided.

Wiring Diagram ATR- 4

~ 230 V/50 Hz

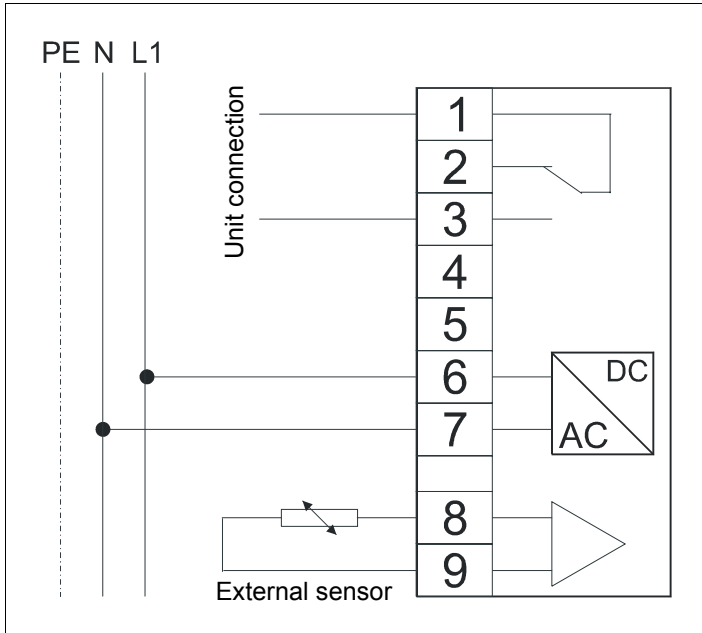

We reserve the right to make technical changes



Note: The control line for the thermostat connection of the REMKO heater is made at terminals 1 and 3. For cooling units, to terminals 1 and 2.



Caution: There must be a power current of ~ 230 V/50 Hz at terminals 6 and 7 at all times for the unit to function

Customer Data

The following tables can be used to enter individual customer data:

Timer program:

Program point	Time	Day(s)	Level
PO1			
PO2			
PO3			
PO4			
PO5			
PO6			
PO7			
PO8			
PO9			
P10			
P11			
P12			
P13			
P14			
P15			
P16			

Control parameters:

Activation difference	
-----------------------	--

or:

Proportional control	
Pulse duration	

Functions:

Sensor comparison	
Heating / Cooling	
2-point / Pulse operation	
Internal / External sensor	
Button lock	

Technical Data

Type	ATR-4
Temperature range	+ 5... + 40 °C
Temperature cooling	2... 10 K, adjustable
Temperature sensor	NTC (internal)
or	KTY (external)
Sensor tolerance	± 1 K
Activation difference	± 0,1... ± 3,0K, adjustable
Proportional control	1...10 K, adjustable
Pulse duration	1...15 min, adjustable
Temperature activation	Target value 0.5 K Current value 0.1 K
Target temperature setting	Rotating knobs
Program points	16
Clock timer	Electronic weekly clock timer
Power reserve ¹⁾	approx. 15 minutes
Display	LC display
Operating current	230 V AC (± 10%)
Power consumption	approx. 2VA
Relay contact	1 isolated change-over contact
Max. supply of switch current	10(4)A, 230 V AC
Electrical connections	Screw terminals
Electrical lifespan	0.5 x 10 ⁵ operating cycles
Max. ambient temperature	0...+ 50 °C
Storage temperature	- 10... + 70 °C
Housing: Material	plastic
Protection type	IP 20
Protection class	II in accordance with DIN EN 60335-1
Dimen. W x H x D	132 x 82 x 32 mm
Attachment	Wall-mounted
Weight	approx. 250 g
Ref. No.	1011340

¹⁾ The power reserve only refers to the time.

All other parameters remain permanently saved.

REMKO GmbH & Co. KG

Klima- und Wärmetechnik

D-32791 Lage · Im Seelenkamp 12

D-32777 Lage · PO Box 1827

Phone +49 (5232) 606 - 0

Fax +49 (5232) 606260

E-Mail: info@remko.de

Internet: www.remko.de